



**National Highways & Infrastructure Development Corporation Ltd.  
(A Government of India Undertaking)**

**Name of the Work: Restoration of Road from Maheshkola- Kanai - Rongara- Panda section of Ranikhor – Maheshkola - Baghmara (SH-04) due to heavy Flood- Construction of vented Causeway (submersible) at Km. 79+250 near Kanai, in the state of Meghalaya for the FY 2022-23.**

**Contract Package no: NHIDCL/RO-SHG/R-M-B/2021/200/1 (Km 79+250)**

**NOTICE INVITING TENDER**

**September, 2022**

# **CONTENTS**

## **Volume-I**

<b>TITLE</b>	<b>DESCRIPTION</b>
<b>SECTION I</b>	<b>NOTICE INVITING TENDER</b>
<b>SECTION II</b>	<b>INSTRUCTIONS TO BIDDER &amp; OBLIGATIONS DURING WORK</b>
<b>SECTION III</b>	<b>SCOPE OF WORK &amp; ADDITIONAL CONDITIONS</b>
<b>SECTION IV</b>	<b>FORMAT FOR DECLARATION &amp; LETTER OF Award and Qualification Information (To be Filled by Bidder)</b>
<b>SECTION V</b>	<b>PRICEBID (BOQ)</b>

**National Highways & Infrastructure Development Corporation Limited**

(Ministry of Road Transport & Highways, Government of India)

**Regional Office- SHILLONG**

(1<sup>ST</sup> and 4<sup>TH</sup> Floor, Parkside Building, Near BSNL, BARIK, Shillong, East Khasi Hills  
Districts, Meghalaya, 793001)(Email-id: edproshillonghidcl@gmail.com)

**NOTICE INVITING TENDER**

**Date: 26.09.2022**

NHIDCL invites sealed tender from the prospective Bidder for the following works:

<b>Sr. no.</b>	<b>Name of work</b>	<b>Estimated Project Cost (Rs in Cr.)</b>	<b>Completion Time</b>
1.	Restoration of Road from Maheshkola- Kanai-Rongara - Panda section of Ranikhor – Maheshkola - Baghmara (SH-04) due to heavy Flood- Construction of vented Causeway (submersible) at Km. 79+250 near Kanai, in the state of Meghalaya for the FY 2022-23	0.44 Cr.	60 days of construction + 365 days of Maintenance Period.

1. The tender be submitted online on cPPP portal and sealed copy may be submitted to NHIDCL Regional Office-Shillong before or on 03.10.2022 (1700 Hrs). The complete process will be online and the tender received will be opened on 05.10.2022 (1200 Hrs).

2. The rates should be quoted excluding GST. Labour Cess and TDS shall be deducted as per applicable law.

3. Cost of Bid Documents:

**Rs. 5,900/- (including GST)** in the form of DD in favour of RO SHILLONG National Highways & Infrastructure Development Corporation Limited (NHIDCL) PAYABLE AT Shillong, Meghalaya (Non-Refundable)

4. **Time schedule:**

Last Date & Time for submission of Tender:	03.10.2022 upto 1700 Hrs
Date & Time of online opening of tender submitted:	05.10.2022 at 1200 Hrs

The prospective bidders can submit their query, if any, on or before 29.09.2022 by 12.00 hours on cPPP portal.

5. The corrigendum or addendum, extension of due date, cancellation of this NIT, if any, shall be hosted on the cPPP portal and on NHIDCL's website, [www.nhidcl.com](http://www.nhidcl.com). The bidders are required to check these websites regularly for this purpose, to take into account before submission of tender.
6. **NHIDCL** reserves the right to accept any tender or reject any or all tender or annul this process without assigning any reason and liability whatsoever and to re-invite this NIT at its sole discretion.
7. Tender may be submitted (physically or by post) to:

Executive Director (Projects)  
National Highways & Infrastructure Development Corporation Ltd.  
Regional Office- Shillong  
(1<sup>ST</sup> and 4<sup>TH</sup> Floor, Parkside Building, Near BSNL, BARIK, Shillong, East  
Khasi Hills Districts, Meghalaya, 793001) (Email-id:  
edproshillongnhidcl@gmail.com)

**8. Contact details for any technical queries:**

Executive Director (Projects)  
National Highways & Infrastructure Development Corporation Ltd.  
Regional Office- Shillong  
(1<sup>ST</sup> and 4<sup>TH</sup> Floor, Parkside Building, Near BSNL, BARIK, Shillong, East  
Khasi Hills Districts, Meghalaya, 793001) (Email-id:  
edproshillongnhidcl@gmail.com)

**Copy to:** PMU-Baghmara/ Tura/ Myllem and its Site Offices for display on their Notice Boards for wide publicity.

## Section-II

### **Introduction**

#### **1. Background**

1.1 The National Highways & Infrastructure Development Corporation Limited (NHIDCL) represented by Managing Director (the “Authority”) is engaged in the development of National Highways and as part of this endeavour, the Authority has decided to undertake the work of “Restoration of Road from Maheshkola- Kanai – Rongara - Panda section of Ranikhor – Maheshkola - Baghmara (SH-04) due to heavy Flood - **Construction of Causeway (submersible) at Km. 79+250 near Kanai** in the state of Meghalaya for the FY 2022-23.” (The “Project”) through an Engineering, Procurement and Construction (the “EPC”) Contract. Brief particulars of the Project are as follows:

<b>Sr. no.</b>	<b>Name of work</b>	<b>Estimated Project Cost (Rs in Cr.) (exclusive of GST)</b>	<b>Completion Time</b>
1.	Restoration of Road from Maheshkola-Kanai – Rongara - Panda section of Ranikhor – Maheshkola - Baghmara (SH-04) due to heavy Flood- <b>Construction of Causeway (submersible) at Km. 79+250 near Kanai</b> , in the state of Meghalaya for the FY 2022-23.	0.44 Cr.	60 days of construction + 365 Days of Maintenance Period

1.2 The selected Bidder (the “Contractor”) shall be responsible for designing, engineering, procurement and construction of the Project under and in accordance with the provisions of an engineering, procurement and construction contract (the “EPC Contract”) to be entered into between the Contractor and the Authority in the form provided by the Authority as part of the Bidding Documents pursuant hereto. The Contractor shall also be responsible for the maintenance of the project during the Defect Liability Period (i.e., 365 days calculated from the Completion date of the above said stretch).

1.3 The estimated cost of the Project (the “Estimated Project Cost”) has been specified in the clause 1.1 above. The assessment of actual costs, however, will have to be made by the Bidders.

1.4 The Bid shall be valid for a period of 120 days from the date as mentioned in Bidding Schedule for submission of BIDs.

1.5 The tentative drawings and design is being provided only as preliminary references as a preliminary reference document by way of assistance to the Bidders who are expected to carry out their own surveys, investigations and other detailed examination of the Project before submitting their Bids. Nothing contained in the Feasibility Report/Detailed Project Report shall be binding on the Authority nor confer any right on the Bidders, and the Authority shall have no liability whatsoever in relation to or arising out of any or all contents of the Feasibility Report/Detailed Project Report.

1.6 Bidders are advised to examine the Project in greater detail, and to carry out, at their cost, such studies as may be required for submitting their respective BIDs for award of the contract including implementation of the Project.

1.7 BIDs will be evaluated for the Project on the basis of the lowest cost required by a Bidder for implementing the Project (the "BID Price"). The total time allowed for completion of construction under the Agreement (the “Construction Period”) and the period during which the Contractor shall be liable for maintenance and rectification of any defect or deficiency in the Project after completion of the Construction Period (the “Defect Liability Period”) shall be pre-determined, and are specified in the RFP/Draft Agreement forming part of the Bidding Documents. In this RFP, the term “Lowest Bidder” shall mean the Bidder who is quoting the lowest BID price.

1.8 No Bidder shall submit more than one BID for the Project.

1.9 No Joint Venture is allowed to participate in bid.

1.10 For this work, no International Bidder is eligible as individually or as a member of any Joint Venture.

## **Instruction to Bidder & Obligations during Work**

### **1. Eligibility Criteria:**

- The Contractor/Bidder (Individual/ firm) should have experience of successfully completed assignment of comprehensive engineering construction work of “**similar works**” during the **last 03 (Three) years** ending last day of month previous to the one in which applications are invited should be either of the following:
  - a. **Three similar works each costing not less than 40% of the estimated cost of the project.**
  - OR**
  - b. **Two similar works each costing not less than 50% of the estimated cost of the project.**
  - OR**
  - c. **One similar work costing not less than 80% of the estimated cost of the project.**

“**Similar work**” shall mean construction of bridges (major or minor) /causeway/culverts on National Highways/State Highways/Major District Road/ Rural Road.

- Supporting documents with respect to completed similar works are required to be submitted along with the bid document, which may be further authenticated by the concerned department/ Authority for its trueness.
- Contractor/Bidder should have in-house design capacity with all latest design software.
- **The Bidder shall have a minimum Net Worth (the “Financial Capacity”) of 10% (ten percent) of the Estimated Project Cost at the close of the preceding financial year**

### **2. SUBMISSIONS TO BE MADE BY DUE DATE:**

- Declaration as performa attached in Section - IV.
- Supporting documents towards completion of similar works.
- **Cost of Bid Documents is Rs. 5,900/- (including GST) in the form of DD in favour of RO SHILLONG National Highways & Infrastructure Development Corporation Limited (NHIDCL) PAYABLE AT Shillong, Meghalaya (Non-Refundable)**

### **3. PRICE BASIS**

Bidder has to quote rates in Rupees as indicated in the NIT. **The cost quoted by the bidder shall be exclusive of GST, inclusive of all other taxes, cess & inclusive of duties etc. for services as applicable under the scope and agreement clauses of the contract.** The rates quoted by the bidder shall include all their expenditures, water, electricity, handling of instruments /equipment’s /materials etc. whatsoever and nothing extra shall be paid to them unless mentioned specifically elsewhere in the document. The Rate shall remain firm through out the contract period and no revision will be allowed.

### **4. SELECTION OF SUCCESSFUL BIDDER:**

- 4.1 The bid submitted by the prospective bidders shall be opened on 16.08.2022 at 1000 Hrs at the premises of NHIDCL RO Shillong. The bid which is least among all bids shall be declared as the successful contractor.
- 4.2 The successful bidder shall be communicated of the same by the Authority through Letter of Award (LOA), subsequent to which the consultant has to be submit, within 7 days of issue of the LOA, **a Demand Draft amounting to 3% of the quoted amount (as calculated from the percentage of Estimated Project Cost quoted)** duly pledged to NHIDCL RO Shillong as a part of security which shall be returned/ released to the Bidder after 365 days calculated from the successful Completion date of the above said stretch (i.e. after the same is duly certified by the General Manager (P), NHIDCL PMU Baghmara.

### **5. PAYMENT PROCEDURE:**

5.1 The rates quoted by bidder shall be exclusive of GST, inclusive of all other taxes, cess & inclusive of duties etc. Payment shall be released to the Contractor as per the terms of the contract documents against submission of GST invoice and all other required documents as mentioned in the contract documents. All statutory deductions shall be made as per norms.

## 5.2 GST

Good & Service Tax (GST) shall be paid to the Contractor along with the Stage Payment at prevailing rate, however, the Contractor has to submit the proof of deposited GST against their work to the Government at the time of submitting next stage payment request failing which paid GST will be deducted.

## 6. PENALTY:

6.1 The instant work is of very urgent nature since the existing Old SPT Bridge at Km 79+250 near Kanai Village has been completely washout due to sever flood. Due to washout of bridge, rest of villages Kanai i.e., Mahadev, Maheshkhola and other inhabited areas are completely disconnected from District HQ, Baghmara, South Garo Hills. The Ranikhor-Maheshkola-Baghmara project is an important project for national security since it is near to International Border with Bangladesh.

6.2 Keeping the above in consideration, if the Contractor fails to submit the deliverables within the stipulated time of completion, a penalty of **Rs 10,000/per** day subject to maximum penalty of 5% of contract price shall be deducted from the payment to be made to the Contractor.

## 7 **Obligation of the Contractor/ Bidder:**

- (i) Subject to and on the terms and conditions of this Agreement, the Contractor shall undertake the construction and maintenance of the Project Highway /structure and observe, fulfill, comply with and perform all its obligations set out in this Agreement or arising hereunder.
- (ii) The Contractor shall comply with all Applicable Laws and Applicable Permits (including renewals as required) in the performance of its obligations under this Agreement.
- (iii) The Contractor shall discharge its obligations in accordance with Good Industry Practice and as a reasonable and prudent person.
- (iv) The Contractor shall remedy any and all loss or damage to the Project Highway/structure from the date of LOA until the end of the Construction Period at the Contractor's cost, save and except to the extent that any such loss or damage shall have arisen from any default or neglect of the Authority.
- (v) The Contractor shall remedy any and all loss or damage to the Project Highway during the Defects Liability Period at the Contractor's cost.
- (vi) The Contractor shall remedy any and all loss or damage to the Project Highway during the Maintenance Period at the Contractor's cost, save and except to the extent that any such loss or damage shall have arisen on account of any default or neglect of the Authority or on account of a Force Majeure Event.
- (vii) The Contractor shall, at its own cost and expense, in addition to and not in derogation of its obligations elsewhere set out in this Agreement:
  - a. make, or cause to be made, necessary applications to the relevant Government Instrumentalities with such particulars and details as may be required for obtaining Applicable Permits and obtain and keep in force and effect such Applicable Permits in conformity with the Applicable Laws;
  - b. procure, as required, the appropriate proprietary rights, licenses, agreements and permissions for

- Materials, methods, processes and systems used or incorporated into the Project Highway;
- c. make reasonable efforts to maintain harmony and good industrial relations among the personnel employed by it in connection with the performance of its obligations under this Agreement;
  - d. not do or omit to do any act, deed or thing which may in any manner be violate of any of the provisions of this Agreement;
  - e. support, cooperate with and facilitate the Authority in the implementation and operation of the Project in accordance with the provisions of this Agreement;
  - f. ensure that the Contractor comply with the safety and welfare measures for labour in accordance with the Applicable Laws and Good Industry Practice;
  - g. Keep, on the Site, a copy of this Agreement, publications named in this Agreement, the Drawings, Documents relating to the Project, and Change of Scope Orders and other communications given under this Agreement. The Authority's Engineer and its authorized personnel shall have the right of access to all these documents at all reasonable times;
  - h. Cooperate with other contractors employed by the Authority and personnel of any public authority; and not interfere unnecessarily or improperly with the convenience of the public, or the access to and use and occupation of all roads and footpaths, irrespective of whether they are public or in the possession of the Authority or of others.
- (viii) The Contractor shall undertake all necessary superintendence to plan, arrange, direct, manage, inspect and test the Works. The Contractor shall provide all necessary superintendence of the Works for the proper fulfilling of the Contractor's obligations under the Agreement. Such superintendence shall be given by competent person having adequate knowledge of the operations to be carried out (including the methods and techniques required, the hazards likely to be encountered and methods of preventing accidents) for the satisfactory and safe execution of the Works.
- (ix) The Contractor shall provide the documents of the Contractor specified in the Agreement, and all Contractors' personnel; Goods, consumables and other things and services, whether of a temporary or permanent nature, required in and for the execution, completion of Works and remedying defects.
- (x) The Contractor shall perform the Works in conformity with the Project requirements and other requirements and standards prescribed under or pursuant to the Agreement.
- (xi) The Contractor shall carry out such work incidental and contingent to the original Scope of the Project to comply with Good Industry Practices.
- (xii) The Contractor shall maintain required staff and necessary Contractor's equipment and materials within the reach of the Site during the Construction and Defects Liability Period so that any defects arising are promptly attended.

## **8. Maintenance**

### **Maintenance obligations of the Contractor**

The Contractor shall maintain the Project Highway for a period of 365 days, corresponding to the Defects Liability Period, commencing from the date of the Completion Certificate (the "Maintenance Period").

## **9. Defect Liability Period**

The Contractor shall be responsible for all the Defects and deficiencies, except usual wear and tear in the Project Highway or any Section thereof, till the expiry of a period of commencing from the date of Completion Certificate (the "Defects Liability Period").

**The Defects Liability Period** shall be 365 days calculated from the Completion Date for the above said stretch.

**The Defects Liability Certificate** is the certificate issued by Engineer, after the Defect Liability Period has ended and upon correction of Defects (if any) by the Contractor.

#### **10. Site visit and verification of information**

Bidders are encouraged to submit their respective BIDs after visiting the Project site and ascertaining for themselves the site conditions, traffic, location, surroundings, climate, availability of construction material, power, water & other utilities for construction, access to site, handling and storage of materials, weather data, applicable laws and regulations, and any other matter considered relevant by them. Bidders are advised to visit the site and familiarize themselves with the Project with in the stipulated time of submission of the Bid. No extension of time is likely to be considered for submission of Bids.

#### **11. Verification and Disqualification**

The Authority reserves the right to verify all statements, information and documents submitted by the Bidder in response to the RFP and the Bidder shall, when so required by the Authority, make available all such information, evidence and documents as may be necessary for such verification. Any such verification, or lack of such verification, by the Authority shall not relieve the Bidder of its obligations or liabilities hereunder nor will it affect any rights of the Authority thereunder.

#### **12. Authority's Engineer**

12.1 Appointment of the Authority's Engineer: "To Be Named"

12.2 Instructions of the Authority's Engineer:

- (i) The Authority's Engineer shall review and approve drawing and design sent to it by the contractor and furnish its comments within 3 days of receiving such a drawings. The review/ approval of drawing should be authenticated by the Authority's Engineer.
- (ii) The Authority's Engineer shall conduct the pre-construction review of manufacturer's reports and standard samples of manufactured Materials, and such other Materials as the Authority's Engineer may require.
- (iii) The Authority's Engineer may issue instructions for remedying any Defect(s) to the Contractor. The Contractor shall take such instructions from the Authority's Engineer.
- (iv) The Authority's Engineer shall test check at least 60(sixty) percent of the quantity or number of tests prescribed for each category or type of test for quality control by the Contractor.
- (v) The instructions issued by the Authority's Engineer shall be in writing. However, if the Authority's Engineer issues any oral instructions to the Contractor, it shall confirm in writing the oral instructions within 2 (two) working days of issuing them.
- (vi) In case the Contractor does not receive the confirmation of the oral instruction, the Contractor shall seek the written confirmation of the oral instructions from the Authority's Engineer. The Contractor shall obtain acknowledgement from the Authority's Engineer of the communication seeking written confirmation. In case of failure of the Authority's Engineer or its delegated assistant to reply to the Contractor within 2 (two) days of the receipt of the communication from the Contractor, the Contractor may not carry out the instruction.
- (vii) In case of any dispute on any of the instructions issued by the delegated assistant, the Contractor may refer the dispute to the Authority's Engineer, who shall then confirm, reverse or vary the instructions within [3 (three)] business days of the dispute being referred.

## Section-III

### Scope of work

#### **1. Scope of Work:-**

##### **A. LOCATION:**

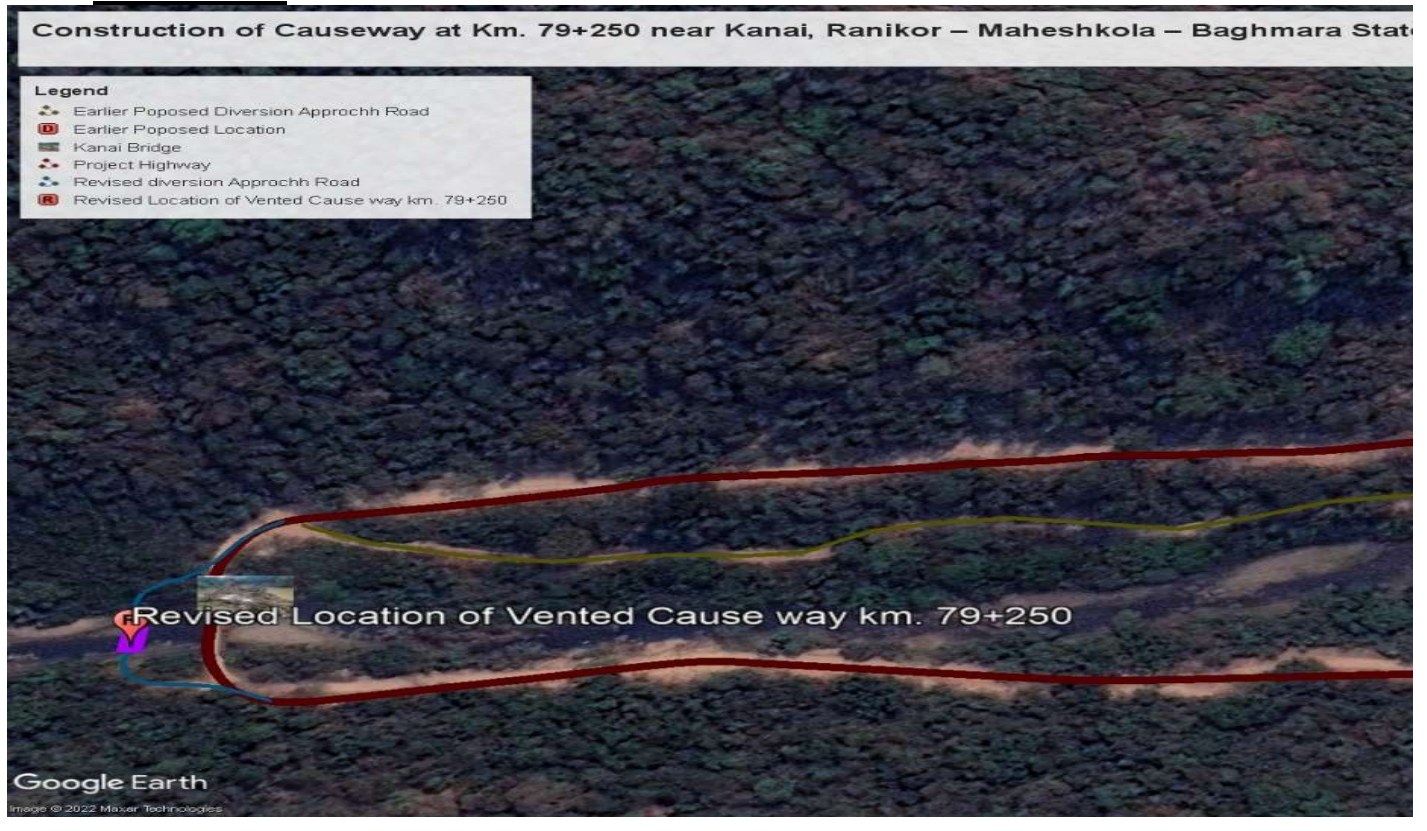

##### **B. TECHNICAL SPECIFICATIONS:-**

#### **1 PREAMBLE:**

The Technical Specifications contained herein shall be read in conjunction with the other Contract Data as specified.

#### **2 GENERAL REQUIREMENTS**

The Technical Specifications in accordance with which the entire work described hereinafter shall be executed and completed by the Contractor shall comprise of the following:

##### **2.1 PART-I-GENERAL TECHNICAL SPECIFICATIONS**

The General Technical Specifications shall be the “SPECIFICATIONS FOR ROAD AND BRIDGE WORKS” (FIFTH REVISION 2013) issued by the Ministry of Road Transport & Highways, Government of India and latest codes published by the Indian Roads Congress, hereinafter referred to as MORT&H Specifications.

##### **PART- II- SUPPLEMENTARY TECHNICAL SPECIFICATIONS**

The Supplementary Technical Specifications shall comprise of various Amendments/ Modifications/Additions to the „SPECIFICATIONS FOR ROAD AND BRIDGE WORKS” referred to in PART-I above and Additional Specifications for particular item of works not already covered in Part- I.

A particular clause or a part there of in “SPECIFICATIONS FOR ROAD AND BRIDGE WORKS”

(FIFTH REVISION), referred in Part -I above, where Amended/ Modified/Added upon and incorporated in Part-II, referred to above, the Amendment/ Modification/ Addition supersedes the relevant clause or part of the clause.

When an Amended/ Modified/ Added Clause supersedes a Clause or part thereof in the said Specifications, then any reference to the superseded clause shall be deemed to refer to the Amended/Modified/Added Clause or part thereof.

In so far Amended/Modified/Added Clause may come in conflict or be inconsistent with any of the provisions of the MOST Specifications under reference, the Amended/Modified/Added clause and the additional specifications shall always prevail.

In the absence of any definite provisions on any particular issue in the aforesaid Specifications, reference maybe made to the latest codes and specifications of IRC and BIS in that order, Where even these are silent, the construction and completion of the works shall conform to sound engineering practice as approved by the Engineer and, in case of any dispute arising out of the interpretation of the above, the decision of the Engineer shall be final and binding on the Contractor.

**C. DESIGN & DRAWING:**

The tentative proposed drawing of Causeway only as preliminary references attached in Annexure-A.

The description of the proposed causeway at Ch. 96+900 are mentioned below-

SI. No.	Particular	Km. 79+250 near Kanai Village
1.	Type of Causeway	High Vented Causeway (submersible)
2.	Formation width of Causeway	6.4 m
3.	Carriageway Width of CW	5.5 m
4.	Length of Vented portion of Causeway	20 m
5.	Width of Approach CW	7 m
6.	Length of Approach Road (Baghmara Side)	7.5 m
7.	Length of Approach Road (Kanai Side)	7.5 m
8.	Crust over Approach Road section	CTSB : 200mm PQC : 250 mm
9.	Standards & Specifications for Design of Causeway	As per IRC:SP: 82-2008, IRC:5, IRC:SP:13-2004 & other relevant codes
10.	Others (Protection works i.e. Guard Wall/Parapet wall)	As per site conditions

**D. Design and Construction of the Project Highway/Structure:**  
**Obligations of Contractor prior to commencement of Works**

Within 07 (seven) days of the date of LOA the Contractor shall:

- (a) Appoint its representative, duly authorized to deal with the Authority in respect of all matters under or arising out of or relating to this Agreement;
- (b) Submit detailed report after surveys, investigations, collection of data, and submission of preliminary and detailed designs;
- (c) undertake and perform all such acts, deeds and things as may be necessary or required before commencement of Works under and in accordance with this Agreement, the Applicable Laws and Applicable Permits; and
- (d) Make its own arrangements for quarrying/ procurement of materials needed for the Project Highway/Structure under and in accordance with the Applicable Laws and Applicable Permits.

**E. EXECUTION OF WORK:**

Work to be executed as per Design & Drawing and Technical Specification mentioned above under

the direction of Engineer in Charge.

## **F. PAYMENT PROCEDURES:**

- a) The contractor shall submit to the Engineer after the completion of stage in all respect in two copies (calculated based on quoted price of each item), each signed by Authorized Contractor's Representative in standard format, showing the amounts to which the contractor considered himself to be entitled. These bills should be prepared each indent wise.
- The Engineer after scrutiny of the bills shall certify and recommend the payments for completed accepted works within 7 days of presentation of bill to him to the employer.
  - **Security Deposit / Retention Money:** - From every payment for Works due to the Contractor in accordance with the provisions of Clause F, the Authority shall deduct 6% (six per cent) thereof as guarantee money for performance of the obligations of the Contractor during the Construction Period (the "Retention Money") subject to the condition that the maximum amount of Retention Money shall not exceed 5% (five per cent) of the Contract Price.
    - (ii) Upon occurrence of a Contractor's Default, the Authority shall, without prejudice to its other rights and remedies hereunder or in law, be entitled to appropriate the relevant amounts from the Retention Money as Damages for such Contractor's Default.
    - (iii) Within 15 (fifteen) days of the date of issue of the Completion Certificate, the Authority shall refund the balance of Retention Money remaining with the Authority after adjusting the amounts appropriated under the provisions of Clause F.
    - (iv) The Parties agree that in the event of Termination of this Agreement, the Retention Money specified in this Clause F shall be treated as if they are Performance Security and shall be reckoned as such for the purposes of Termination Payment.
  - The employer shall pay the amount due to the Contractor under certificate and recommendations by the Engineer within 15 days after it has been delivered to the Employer.

b) **Records & Documentation**

The results of all inspections shall be documented. The test results containing documentary evidence of activities and data relevant to the quality of work and performance of the contractor shall also be documented. The field report daily to be filled by Site Engineer of Contractor shall be a basic form of documentation. The activities to be entered in daily dairy are

- The description of day's activities, number and type of crew on job, equipment on job weather and temperature
- Any measurement made to determine pay quantities.
- Daily summary of material issued in the job.
- A record of significant conversations with and direction given to the contractor.
- A record of bottlenecks with the progress or execution of the work.
- A record of material testing in lab.
- Details of visit by officials.

## **G. Payment Schedule:**

The Contractor will be paid stage-wise as a percentage of the Contract value.

Sl. No.	Item	Payment %
1.	Completion of Foundation	20%
2.	Completion of Vent Section / structures	60%
3.	Completion of Others	10 %
4.	Completion of Approach Road	10%
5.	Payment during DLP	2.5%

## **H. Maintenance obligations of the Contractor**

(i) The Contractor shall maintain the Project Highway for a period of 01 (one) year, corresponding to the Defects Liability Period, commencing from the date of the Completion Certificate (the "Maintenance Period"). For the performance of its Maintenance obligations, the Contractor shall be paid:

(a) For instant scope with 1-year Maintenance Period including structures: 0.625% of the Contract Price each for the first, second, third and fourth quarter of year;

(ii) During the Maintenance Period, the Authority shall provide to the Contractor access to the Site for Maintenance in accordance with this Agreement. The obligations of the Contractor hereunder shall include:

(a) permitting safe, smooth and uninterrupted flow of traffic on the Project Highway;

(b) undertaking routine maintenance including prompt repairs of potholes, cracks, joints, drains, embankments, structures, pavement markings, lighting, road signs and other traffic control devices.

For the avoidance of doubt, the electricity charges for operation of electrical infrastructure installed along the project length, except the infrastructure being used by the Contractor for its own use, shall be borne by the Authority;

(c) undertaking repairs to structures;

(d) Informing the Authority of any unauthorized use of the Project Highway;

(e) Informing the Authority of any encroachments on the Project Highway; and

(f) operation and maintenance of all communication, patrolling, and administrative systems necessary for the efficient maintenance of the Project Highway in accordance with the provisions of this Agreement.

(iii) In the event that the Contractor fails to repair or rectify any Defect or deficiency set forth in specifications within the period specified therein, it shall be deemed as failure of performance of Maintenance obligations by the Contractor and the Authority shall be entitled to effect reduction in monthly lump sum payment for maintenance, without prejudice to the rights of the Authority under this Agreement, including Termination thereof.

(iv) If the nature and extent of any Defect justifies more time for its repair or rectification than the time specified in Schedule-E, the Contractor shall be entitled to additional time in conformity with Good Industry Practice. Such additional time shall be determined by the Authority's Engineer and conveyed to the Contractor and the Authority with reasons thereof.

(v) In the event the Contractor does not maintain and/or repair the Project Highway or any part thereof in conformity with the Maintenance Requirements, the Maintenance Manual or the Maintenance Programme, as the case may be, and fails to commence remedial works within 15 (fifteen) days of receipt of the Maintenance Inspection Report or a notice in this behalf from the Authority or the Authority's Engineer, as the case may be, the Authority shall, without prejudice to its rights under this Agreement including Termination thereof, be entitled to undertake such remedial measures at the cost of the Contractor, and to recover its cost from the Contractor. In addition to recovery of the aforesaid cost, a sum equal to 20% (twenty per cent) of such cost shall be paid by the Contractor to the Authority as Damages.

## ADDITIONAL CONDITIONS

- 1) Before quoting, the contractor shall inspect the site of work and shall full acquaint himself the above terms and conditions with regard to site, nature of soil, availability of material suitable location for execution of work and time involved in the work (over the entire duration of contract) including local conditions that restrictions, obstructions and other conditions, as required for satisfactory and timely execution of the work. Rates should take into consideration all such factors like supply and storage of materials, man and machinery, land etc. and contingencies. No claim whatsoever shall be entertained by the NHIDCL on this account.
- 2) The contractor must study the specifications and conditions carefully before tendering.
- 3) Before the start of the work, the contractor shall submit the program of execution of work, get it approved from the Engineer/ NHIDCL and strictly adhere the same for the timely completion of the project work.
- 4) The contractor shall have to make approaches to the site, if so required and keep them in good condition for transportation of labour and materials as well as inspection of work by the Engineer. Nothing extra shall be paid on this account.
- 5) The contractor shall all times carryout work on the highway in a manner creating No interference in the flow of traffic as per direction of Engineer/Employer
- 6) All arrangements for traffic diversion during construction including M&R works for diversion road shall be considered as incidental to the work and contractor's responsibility and nothing shall be payable to him in this respect. However, if any new diversion road is constructed by the contractor, the same shall be paid separately.
- 7) The work shall be carried out in such a manner so as not to interfere or effect or disturb either works, being executed by other agencies, if any.
- 8) Any damage done by the contractor to any existing work shall be made good by him at his own cost.
- 9) The work shall be carried out in the manner complying in all respect with the requirement of relevant bye-laws of the local bodies under the jurisdiction of which the work is to be executed and nothing extra shall be paid on this account.
- 10) For completing the work in time, the contractor might be required to work in two or more shifts including night shifts and no claim whatsoever shall be entertained on this account notwithstanding the facts that the contractor will have to pay to the labourers and other staff engaged directly or indirectly on the work according to the provision of the law regulation and the agreement entered upon and/ or extra amount for any other reason.
- 11) The contractor shall make his own arrangements for obtaining electric connection(s) as required and make necessary payment directly to the department concerned. The Department will however make all reasonable recommendations to the authority concerned in this regard.
- 12) The contractor or his authorized representative should always be available at the site of work to take instructions from Engineer or his authorized representative and ensure proper execution of work(s) or work should not be done in the absence of such authorized representative.
- 13) The structural and other drawings for the work, shall at all times, be properly corrected before executing the work.
- 14) The contractor shall maintain in good condition all works executed till the completion of the entire work allotted to the contractor.
- 15) No payment will be made to the contractor for damage caused by rains, or other natural calamities during the execution of works and no such claims on this account will be entertained.
- 16) Royalty at the prevalent rates and all other incidental expenditure shall have to be paid by the contractor on all the boulders, metal, earth, sand, bajri etc. collected him for the execution of the work direct to the concerned Revenue Authority of the state or central Govt. His rates are deemed to include all such expenditure and nothing extra shall be paid.
- 17) The contractor shall take all necessary measures for the safety of traffic during construction period, erect and maintain such barricades, including signs, markings, flags, lights and flagman, as necessary at either end of the excavation embankment and at such intermediate points as directed by the Engineer for the

proper identification of construction area. The Contractor's rate shall include above items of work and nothing extra shall be paid to Contractor. He shall be responsible for all damages and accidents caused due to negligence on the part.

- 18) The contractor shall provide suitable barricading with suitably painted single row of the sheets about 3'-0" wide (90cms) nailed or bolted with wooden poles spaced 2 to 3 meter apart and each pole 1.6m to 2m long, 8 cm to 10 cm dia. The poles will be embedded to mobile iron pedestal rings suitably framed for giving stable support without hindrances to the traffic as per direction of the Engineer/ NHIDCL I. All management (including, watch and ward) of barricades shall be the full responsibility of the contractor. The barricade shall be removed only after completion of the work or part of the work. The contractor's rates which include all above items of work and nothing extra shall be paid to the contractor over and above his quoted rates.
- 19) The temporary warning lamps shall be installed at all barricades during the hours of darkness and kept lit at all times during these hours.
- 20) The malba/garbage, removed from the site shall be disposed off by the contractor at any suitable place as directed by the Engineer.
- 21) All work and materials brought and left upon the ground by the contractor or by his order for the purpose of forming part of the works are to be considered to be the property of the NHIDCL and the same are not to be removed or taken away by the contractor or any other person without special license and consent in writing of the Engineer/ NHIDCL but the NHIDCL is not be in any way responsible for any loss or damaged which may happen to or in respect of any such work or materials either by the same being lost or damaged by weather or otherwise.
- 22) The Contractor will be responsible to provide deep hand pump/tube well at site of work to make potable and safe drinking water to labour engaged in execution of work.
- 23) The rates for all items of work, unless clearly specified otherwise, shall include the cost of all labour, materials dewatering and other inputs involved in the execution of the items. If any reason contractor fails to quote his rate for any item provided in the schedule of quantities it will be assumed that contractor is ready to execute that item free of cost.
- 24) Unless otherwise provided in the schedule of quantities the rates tendered by the contractor shall be all-inclusive and shall apply to all heights, depths, leads and lifts.
- 25) The contractor shall bear all incidental charges for cartage, storage and safe custody of materials.
- 26) The nature of work is such that contractor may have to carry out a part of work announced not less than Rs. 50,000/- (Fifty Thousand) or full work on short notice of 48 hours from Engineer in writing on site order book or through special messenger. Failure to comply with the instruction or delay in taking up the work as per schedule issued by the Engineer shall attract penalty clause as mentioned in the agreement. In addition a fine of Rs.1000/-per day for each day of default shall be recovered from contractor and decision of Engineer shall be final, binding and not open to arbitration.
- 27) Existing drains, pipes, cables, overhead wires, sewer lines, water line and similar services encountered in the course of the execution of the work shall be protected against the damages by the contractor. The contractors shall not store material or otherwise occupy any part of the site in a manner likely to hinder the operation of such services.
- 28) The contractor will not have any claim in case of any delay by the Engineer in removal of trees or shifting, removing of telegraph, telephone or electric lines (overhead and underground), water and sewer lines and other structure etc. if any, which may come in the way of the work. However, suitable extension of time can be granted to cover such delay.
- 29) Stipulated material shall be arranged by the contractor at site of work or all the items where such materials are required.
  - i) Tendered rates are inclusive of all taxes and levies payment under the respective statutes. However, pursuant to the constitution (46<sup>th</sup> amendment) Act 1982, it also further tax or levy is imposed by statute, after the date of receipt of tenders and the contractor there upon necessarily and properly pays such taxes/levies, the contractor shall be reimburse the amount so paid, provided such payment, if any, is not in the opinion of General Manager (P) / Executive Director(P) whose

decision shall be final and binding) attributable to delay in execution of the work within the control of the contractor.

- ii) The contractor shall keep necessary books of account and other documents for the purpose of this condition as may be necessary and shall allow inspection of the same by a duly authorized representative of Govt. and further shall furnish such other information/documents as Engineer may require.
  - iii) The contractor shall within a period of 30 days of imposition of any further tax or levy in pursuant to the constitution of (46<sup>th</sup> Amendment) Act 1982, given a written notice thereof to the Engineer that the same is given pursuant to this condition together with all necessary information relating thereto.
- 30) Contractor may be required to execute this work under foul position. The decision of the Engineer whether the position is foul or not shall be final and the quoting of the contractor and nothing extra for executing the work in foul position is payable, beyond what is provided in the schedule of quantities.
- 31) Any Additional provision to keep structure safe from slippage, damage during high flood etc, such as anchoring, shear key, Flooring & pitching or any technology shall be taken by EPC contractor and it will not be considered as change of scope neither qualified for any additional payment.
- 32) The length / components of Structures and approach roads specified hereinabove shall be treated as an approximate assessment. The actual lengths as required on the basis of detailed investigations shall be determined by the Contractor in accordance with the Specifications and Standards. Any variations in the lengths specified in this scope shall not constitute a Change of Scope.

**Section-IV**

**DECLARATION FORMAT**

**(To be printed in a stamp paper of Rs 100 or above and to be notarized)**

**Date: .....**

I/We hereby submit a declaration that the bid submitted by the undersigned shall not be withdrawn or modified during period of validity i.e., not less than 100 (one hundred) days from the due date.

I/We, also accept the fact that in case the bid is withdrawn or modified during the period of its validity or if we fail to sign the contract in case the work is awarded to us or we fail to submit the DD towards security before the deadline defined in clause 4.2, Section-II of the document, then (Name of consultant) will be suspended for participating in any bidding process for the work of MoRTH/NHAI/NHIDCL and work under other Centrally Sponsored Scheme, for a period of one year from the due date of this work.

(Signature of the Authorized Signatory)  
(Official-Seal)

**FORM OF LETTER OF AWARD**

No.....

Dated.....

To

.....

Sub:.....Name of Work.....

Sir,

Based on your bid submitted on.....incompliance of document of NHIDCL for execution of the work of....., it is hereby Notified that your bid for a quoted price of Rs.....(Rupees in words.....), has been accepted for and on behalf of NHIDCL.

You are hereby requested to furnish Demand Draft towards Security as detailed in para. 4.2 of ITB for an amount equivalent to Rs .....(Rupees in words.....) within 7 days as per provisions of clause 4.2 of ITB of the document.

Thanking you,

Yours

faithfully,(..... )

Executive Director (Projects)

Accepted by

(Name of Authorized Person)

(Name of Bidder)

(Seal of the Bidder)

**SAMPLE FORMAT FOR EVIDENCE OF ACCESS TO OR AVAILABILITY OF  
CREDIT FACILITIES**

**BANK CERTIFICATE**

This is to certify that M/s..... is a reputed company `with a good financial standing.

If the contact for the work, namely .....is awarded to the above firm, we shall be able to provide overdraft/credit facilities to the extent of Rs..... to meet their working capital requirements for executing the above contract during the contract period.

-----

(Signature)  
Name of Bank Senior Bank Manager  
Address of the Bank

**AFFIDAVIT**

1. I, the undersigned, do hereby certify that all the statements made in the enclosed attachments are true and correct.
2. The undersigned also hereby certifies that neither our firm M/s \_\_\_\_\_ has abandoned any work on State/ National Highways nor any contract awarded to us for such works have been rescinded, during last five years prior to the date of this bid.
3. The undersigned hereby authorize(s) and request(s) any bank, person, firm or corporation to furnish pertinent information deemed necessary and requested by NHIDCL to verify this statement or regarding my (our) competence and general reputation.
4. The undersigned understands and agrees that further qualifying information may be requested, and agrees to furnish any such information at the request of the NHIDCL and within the prescribed time.

\_\_\_\_\_  
(Signed by an Authorized Representative of the Firm)

\_\_\_\_\_  
Name of the Representative

\_\_\_\_\_  
Name of Firm

\_\_\_\_\_  
DATE

To be notarized by Notary

(To be notarized by Notary)

**UNDERTAKING**

I, the undersigned do hereby undertake that our firm M/s \_\_\_\_\_ would invest minimum cash up to 25% of the value of the work during implementation of the Contract towards the working capital.

\_\_\_\_\_  
(Signed by an Authorized Representative of the Firm)

\_\_\_\_\_  
Name of the Representative

\_\_\_\_\_  
Name of Firm

\_\_\_\_\_  
DATE

(To be notarized by Notary)

**UNDERTAKING**

1 I, the undersigned do hereby undertake that our firm M/s. \_\_\_\_\_ agree to abide by this bid for a period of \_\_\_\_\_ days after the date fixed for receiving the same and it shall be binding on us and may be accepted at any time before the expiration of that period.

\_\_\_\_\_  
(Signed by an Authorized Representative of the Firm)

\_\_\_\_\_  
Name of the Representative

\_\_\_\_\_  
Name of Firm

\_\_\_\_\_  
DATE

# FORM OF AGREEMENT

## AGREEMENT

This agreement made the \_\_\_\_\_ day of \_\_\_\_\_ 2022 between the National Highways & Infrastructure Development Corporation Ltd., Shillong (hereinafter called “the Employer” of the one part and \_\_\_\_\_ (here in after called “the Contractor”) of the other part.

AND WHEREAS the Employer invited bids from eligible bidders of the execution of certain works, viz **“Restoration of Road from Maheshkola- Kanai - Rongara- Panda section of Ranikhor – Maheshkola - Bagmara (SH-04) due to heavy Flood- Construction of vented Causeway (submersible) at Km. 79+250 near Kanai,in the state of Meghalaya for the FY 2022-23”** Contract Package no: NHIDCL/RO-SHG/R-M-B/2021/200/1 (Km 79+250) AND WHEREAS pursuant to the bid submitted by the Contractor, vide letter dated ----- (here in after referred to as the “**BID**” or “**ÖFFER**”) for the execution of works, the Employer by his letter of acceptance dated ----- accepted the offer submitted by the Contractor for the execution and completion of such works and the remedying of any defects thereon, on terms and conditions in accordance with the documents listed in para 2 below.

AND WHEREAS the Contractor by a deed of undertaking dated ----- has agreed to abide by all the terms of the bid, including but not limited to the amount quoted for the execution of Contract, as stated in the bid, and also to comply with such terms and conditions as may be required from time to time.

AND WHEREAS pursuant to the bid submitted by the Contractor vide letter dated ----- (hereinafter referred to as the “the Offer”), the employer has by his letter of acceptance no.----- accepted the offer submitted by the Contractor for the execution and completion of such works and the remedying of any defects therein, on terms and conditions in accordance in the conditions of particular application and condition included hereinafter;

AND WHEREAS the contractor has agreed to undertake such works and has furnished a performance security pursuant to Clause 4.2 of the instructions to bidders, Section-II.

NOW THIS AGREEMENT WITNESSETH as follows:

- 1 In this agreement works and expressions shall have the same meanings as are respectively assigned to them in the conditions of contract hereinafter referred to;
- 2 The following documents shall be deemed to form and be read and constructed as part of this agreement viz.
  - a) The Contract Agreement,
  - b) Letter of Acceptance,
  - c) Notice to proceed with the works,
  - d) Contractor's Bid,
  - e) Contract Data,
  - f) Conditions of Contract including Special Conditions of Contract
  - g) Technical Specifications,
  - h) Drawings, if any
  - i) Scope of work
  - j) Bill of Quantities
  - k) Any other document listed in the Contract Data.
- 3 The foregoing documents shall be constructed as complementary and mutually explanatory one with another. Should any ambiguities or discrepancy be noted then the order of precedence of these documents shall subject to the condition of particular applications be as listed above.
- 4 In consideration of the payments to be made by the Employer to the Contractor as hereinafter mentioned, the Contractor hereby covenants with the Employer to execute and complete the works and remedy any defects therein in conformity in all respect with the provisions of the contract.
- 5 the employer hereby covenants to pay the contractor in consideration of the execution and completion of the works and the remedying of defects therein the contract price or such other sum as may become payable under the provisions of the contract at the times and in the manner prescribed by the contract.

IN WITNESS WHEREOF the parties here to have caused this agreement to be executed the day and year first before written, signed, sealed and delivered by the said Employer through his Authorized Representative and the said Contractor through his Power of Attorney holder in the presence of:

**Binding Signature of Employer** \_\_\_\_\_

For and on behalf of  
National Highways & Infrastructure Development Corporation Ltd.  
RO-Shillong, NHIDCL,  
1st Floor Parkside Building,  
Opp. Lady Hydari Park,  
Barik, Shillong,  
Meghalaya-793001  
Email:edp.shillong@nhidcl.com

**Binding Signature of Contractor** \_\_\_\_\_

For and on behalf of \_\_\_\_\_

<b>In the presence of</b>		<b>In the Presence of</b>	
1.	Name:	1.	Name:
	Address:		Address:
2.	Name:	2.	Name:
	Address:		Address:

## Section-V

Validate

Print

Item

Help

Tender Inviting Authority: National Highways Infrastructure Development Corporation Limited

Name of Work: Restoration of Road from Maheshkola- Kanai - Ronagar- Panda section of Ranikor – Maheshkola - Baghmara (SH-04) due to heavy Flood- Construction of vented Causeway (submersible) at Km. 79+250 near Kanai, in the state of Meghalaya for the FY 2022-23.

Contract No:

Name of the Bidder/ Bidding Firm / Company :

**PRICE SCHEDULE**

(This BOQ template must not be modified/replaced by the bidder and the same should be uploaded after filling the relevent columns, else the bidder is liable to be rejected for this tender. Bidders are allowed to enter the Bidder Name and Values only )

NUMBER #	TEXT #	NUMBER #	TEXT #	NUMBER #	NUMBER #	TEXT #
Sl. No.	Item Description	Quantity	Units	BASIC RATE In Figures To be entered by the Bidder (Inclusive of all taxes) Rs. P	TOTAL AMOUNT Without Taxes (Inclusive of all taxes) Rs. P	TOTAL AMOUNT In Words
1	2	4	5	13	53	55
1	High Vented Causeway including Approach Road (at both sides of Vented Causeway)	1.00	unit			
<b>Total in Figures Quoted Rate in Words</b>				<b>INR</b>		



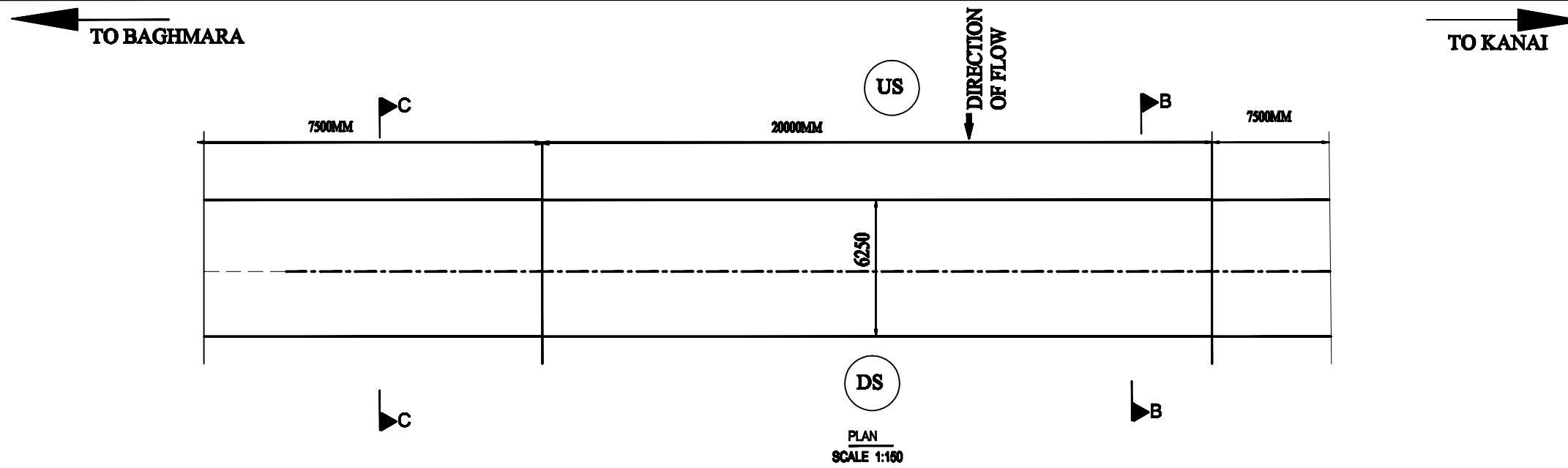

- NOTES:-**
- ALL DIMENSIONS ARE IN MILLIMETERS, LEVELS ARE IN METERS UNLESS OTHERWISE MENTIONED.
  - NO DIMENSION SHALL BE MEASURED FROM THE DRAWINGS. ONLY WRITTEN DIMENSIONS SHALL BE FOLLOWED.
  - THE REINFORCEMENT SHALL BE HYSD BARS OF GRADE DESIGNATION Fe 500D CONFORMING TO IS 1786-2008
  - BACK FILLING SHALL CONSIST OF SELECTED EARTH CONFORMING TO APPENDIX : 6 OF IRC : 78-2014 HAVING PROPERTIES  $C=0$ ,  $\phi > 30^\circ$ ,  $\mu = 20^\circ$ ,  $d = 20$  kN/m<sup>2</sup>
  - CONCRETE SHALL BE DESIGN MIX WITH A MINIMUM 28 DAYS CHARACTERISTIC CUBE STRENGTH FOR DIFFERENT ELEMENTS AS FOLLOWS:
    - a) RCC BOX
    - b) RCC RETAINING WALL
    - c) RCC DECK SLAB
    - d) RCC LEVELING COURSE
    - e) PCC

**LEGEND:**

FRL	: FINISH ROAD LEVEL
GL	: GROUND LEVEL
LVL	: LEVEL
EJ	: EXPANSION JOINT
CW	: CARRIAGEWAY
CL	: CENTRE LINE
RCC	: REINFORCED CEMENT CONCRETE
PCC	: PLAIN CEMENT CONCRETE
No. (No's)	: NUMBER(S)
TYP.	: TYPICAL
FDN.	: FOUNDATION

**LEVEL DETAILS:**

LEVELS	
FRL	
RCC BOX TOP LVL.	
BED LEVEL	
FDN. LEVEL	

ALL LEVELS SHALL BE VERIFIED AT SITE BEFORE EXECUTION OF WORK.

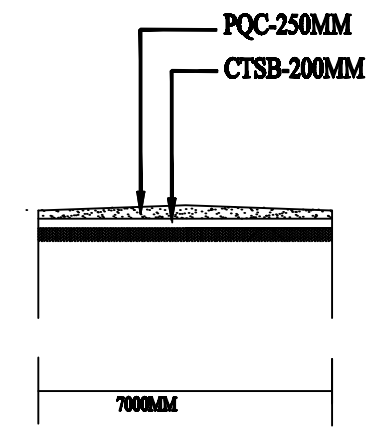
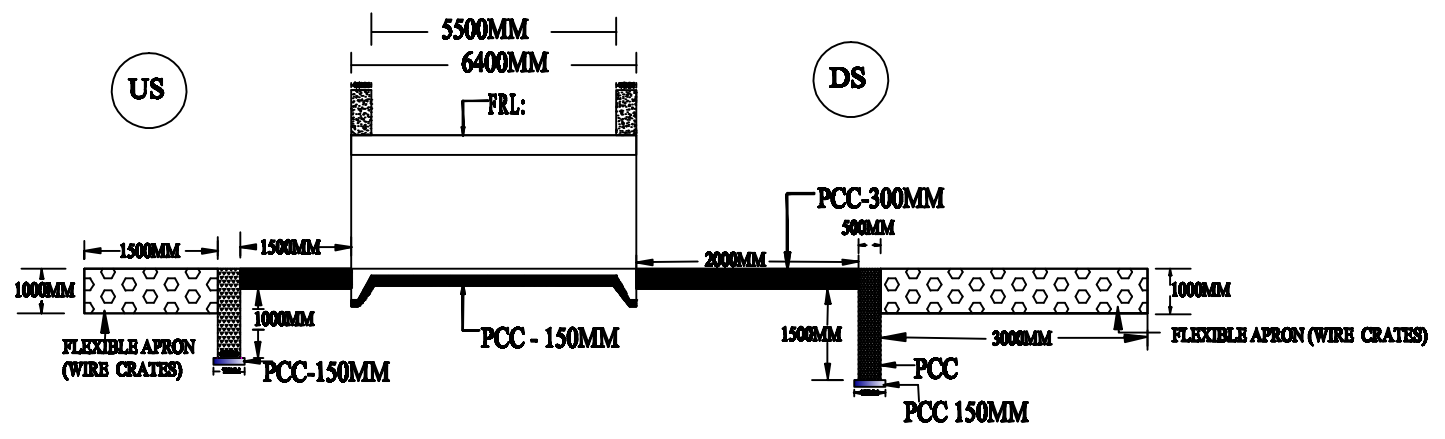
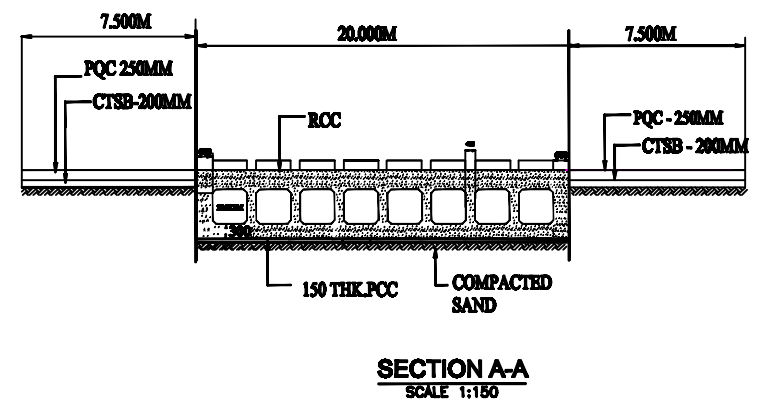

REV. NO.	DATE	DESCRIPTION	DRAWN	CHECKED	APPROVED

Client : National Highway and Infrastructure Development Corporation Ltd.

NAME OF SCHEME : GAD - SUBWAY -101-SH-01-

WORKING DRAWING

Type : SUBWAY BRIDGE

Chainage :

Scale - As Shown (in A3 size paper)