

**NATIONAL HIGHWAYS & INFRASTRUCTURE
DEVELOPMENT CORPORATION LTD.**

(Ministry of Road, Transport & Highways)

Government of India

CONTRACT AGREEMENT & SCHEDULES

Construction of Two Lane “Chisopani Traffic Tunnel” of Length 250 m including approaches from Km 67+080 to Km 67+500 on NH-10 in East District of Sikkim State on EPC mode

Engineering, Procurement & Construction
(EPC) Mode



National Highways & Infrastructure Development Corporation Ltd. (A Government of India Undertaking)

December-2018

Table of Contents

Part I.....	10
Preliminary	10
1 Definitions and Interpretations	14
1.1. Definitions	14
1.2. Interpretation	21
1.3. Measurements and arithmetic conventions	23
1.4. Priority of agreements and errors/discrepancies	24
1.5. Joint and several liability	24
Part II	26
Scope of Project	26
2 Scope of the Project	27
2.1. Scope of the Project	27
3 Obligations of the Authority	28
3.1. Obligations of the Authority	28
3.2. Maintenance obligations prior to the Appointed Date	29
3.3. Environmental Clearances	30
3.4. Deemed Termination upon delay	30
4 Obligations of the Contractor	31
4.1. Obligations of the Contractor	31
4.2. Obligations relating to sub-contracts and any other agreements	33
4.3. Employment of foreign nationals	34
4.4. Contractor's personnel	34
4.5. Advertisement on Project Highway	35
4.6. Contractor's care of the Works	35
4.7. Electricity, water and other services	35
4.8. Unforeseeable difficulties	35
4.9. Co-ordination of the Works	35
4.10. Environmental Measures	36
4.11. Site Data	36
4.12. Sufficiency of Contract Price	36
4.13. Clearance of the Site	37
5 Representations and Warranties	38
5.1. Representations and warranties of the Contractor	38
5.2. Representations and warranties of the Authority	41
5.3. Disclosure	42
6 Disclaimer	43
6.1. Disclaimer	43
Part III.....	44
Construction and Maintenance	44
7 Performance Security.....	45
7.1. Performance Security	45
7.2. Extension of Performance Security and Additional Performance Security	46

7.3.	Appropriation of Performance Security	46
7.4.	Release of Performance Security	46
7.5.	Retention Money	47
8	Right of Way	48
8.1.	The Site	48
8.2.	Procurement of the Site	48
8.3.	Damages for delay in handing over the Site	49
8.4.	Site to be free from Encumbrances	51
8.5.	Protection of Site from encroachments	51
8.6.	Special/ temporary Right of Way	52
8.7.	Access to the Authority and the Authority's Engineer	52
8.8.	Geological and archaeological finds.....	52
9	Utilities and Trees	53
9.1.	Existing utilities and roads	53
9.2.	Shifting of obstructing utilities.....	53
9.3.	New utilities.....	53
9.4.	Felling of trees	54
9.5.	Dismantling of structures	54
9.6.	Development Period	54
10	Design and Construction of the Project Highway	56
10.1.	Obligations prior to commencement of Works	56
10.2.	Design and Drawings.....	58
10.3.	Construction of the Project Highway	60
10.4.	Maintenance during Construction Period	61
10.5.	Extension of time for completion	62
10.6.	Incomplete Works.....	63
10.7.	Maintenance Manual	63
10.8.	As-Built Records.....	64
10.9.	Contractor's Use of Authority's Documents	64
11	Quality Assurance, Monitoring and Supervision.....	65
11.1.	Quality of Materials and workmanship.....	65
11.2.	Quality control system	65
11.3.	Methodology	65
11.4.	Inspection and technical audit by the Authority	66
11.5.	External technical audit.....	66
11.6.	Inspection of construction records	66
11.7.	Monthly progress reports.....	66
11.8.	Inspection	68
11.9.	Samples	68
11.10.	Tests	68
11.11.	Examination of work before covering up	69
11.12.	Rejection.....	69
11.13.	Remedial work.....	69
11.14.	Delays during construction	70
11.15.	Quality control records and Documents	70
11.16.	Video recording.....	70
11.17.	Suspension of unsafe Construction Works.....	70
11.18.	Staff and Labour.....	71

12	Completion Certificate	75
12.1.	Tests on Completion	75
12.2.	Completion Certificate	75
12.3.	Rescheduling of Tests.....	76
13	Change of Scope.....	77
13.1.	Change of Scope.....	77
13.2.	Procedure for Change of Scope	77
13.3.	Payment for Change of Scope.....	79
13.4.	Restrictions on Change of Scope.....	79
13.5.	Power of the Authority to undertake Works.....	80
14	Maintenance.....	81
14.1.	Maintenance obligations of the Contractor	81
14.2.	Maintenance Requirements	82
14.3.	Maintenance Programme.....	82
14.4.	Safety, vehicle breakdowns and accidents	83
14.5.	Lane closure	83
14.6.	Reduction of payment for non-performance of Maintenance obligations.....	83
14.7.	Authority's right to take remedial measures.....	84
14.8.	Restoration of loss or damage to Project Highway.....	84
14.9.	Overriding powers of the Authority	84
14.10.	Taking over Certificate	85
15	Supervision and Monitoring during Maintenance.....	86
15.1.	Inspection by the Contractor	86
15.2.	Inspection and payments	86
15.3.	Tests	87
15.4.	Reports of unusual occurrence	87
16	Traffic Regulation.....	88
16.1.	Traffic regulation by the Contractor	88
17	Defects Liability	89
17.1.	Defects Liability Period.....	89
17.2.	Remedying Defects	89
17.3.	Cost of remedying Defects	89
17.4.	Contractor's failure to rectify Defects	90
17.5.	Extension of Defects Liability Period.....	90
18	Authority's Engineer	91
18.1.	Appointment of the Authority's Engineer	91
18.2.	Duties and authority of the Authority's Engineer	91
18.3.	Delegation by the Authority's Engineer	92
18.4.	Instructions of the Authority's Engineer	92
18.5.	Determination by the Authority's Engineer.....	93
18.6.	Remuneration of the Authority's Engineer.....	93
18.7.	Termination of the Authority's Engineer.....	93
Part IV	94
Financial Covenants	94
19	Payments.....	95

19.1.	Contract Price	95
19.2.	Advance Payment	95
19.3.	Procedure for estimating the payment for the Works.....	97
19.4.	Stage Payment Statement for Works.....	98
19.5.	Stage Payment for Works.....	98
19.6.	Monthly Maintenance Statement of the Project Highway	98
19.7.	Payment for Maintenance of the Project Highway.....	99
19.8.	Payment of Damages	99
19.9.	Time of payment and interest	100
19.10.	Price adjustment for the Works.....	100
19.11.	Restrictions on price adjustment.....	103
19.12.	Price adjustment for Maintenance of Project Highway	103
19.13.	Final Payment Statement	104
19.14.	Discharge	104
19.15.	Final Payment Certificate	104
19.16.	Final payment statement for Maintenance.....	105
19.17.	Change in law.....	105
19.18.	Correction of Interim Payment Certificates.....	106
19.19.	Authority's claims.....	106
19.20.	Bonus for early completion	106
20	Insurance.....	107
20.1.	Insurance for Works and Maintenance	107
20.2.	Notice to the Authority	108
20.3.	Evidence of Insurance Cover	108
20.4.	Remedy for failure to insure.....	108
20.5.	Waiver of subrogation.....	108
20.6.	Contractor's waiver	109
20.7.	Cross liabilities	109
20.8.	Accident or injury to workmen	109
20.9.	Insurance against accident to workmen	109
20.10.	Application of insurance proceeds.....	110
20.11.	Compliance with policy conditions	110
20.12.	General Requirements of Insurance Policies.....	110
Part V	112
Force Majeure and Termination	112
21	Force Majeure.....	113
21.1.	Force Majeure.....	113
21.2.	Non-Political Event.....	113
21.3.	Indirect Political Event.....	114
21.4.	Political Event	114
21.5.	Duty to report Force Majeure Event	115
21.6.	Effect of Force Majeure Event on the Agreement.....	115
21.7.	Termination Notice for Force Majeure Event.....	116
21.8.	Termination Payment for Force Majeure Event	116
21.9.	Dispute resolution.....	117
21.10.	Excuse from performance of obligations	117
22	Suspension of Contractor's Rights	118
22.1.	Suspension upon Contractor Default	118

22.2.	22.2 Authority to act on behalf of Contractor	118
22.3.	Revocation of Suspension	118
22.4.	Termination	118
23	Termination	120
23.1.	Termination for Contractor Default	120
23.2.	Termination for Authority Default	122
23.3.	Termination for Authority's convenience.....	123
23.4.	Requirements after Termination	124
23.5.	Valuation of Unpaid Works	124
23.6.	Termination Payment.....	124
23.7.	Other rights and obligations of the Parties	125
23.8.	Survival of rights	126
23.9.	Foreclosure with mutual consent	126
Part VI	127
Other Provisions	127
24	Assignment and Charges	128
24.1.	Restrictions on assignment and charges.....	128
24.2.	Hypothecation of Materials or Plant	128
25	Liability and Indemnity	129
25.1.	General indemnity.....	129
25.2.	Indemnity by the Contractor	129
25.3.	Notice and contest of claims	130
25.4.	Defence of claims.....	130
25.5.	Survival on Termination	131
26	Dispute Resolution.....	132
27.1.	Dispute Resolution.....	132
27.2.	Conciliation	132
27.3.	Arbitration.....	132
27.4.	Adjudication by Regulatory Authority, Tribunal or Commission	134
27	Miscellaneous	135
27.1.	Governing law and jurisdiction	135
27.2.	27.2 Waiver of immunity.....	135
27.3.	Delayed payments.....	135
27.4.	27.4 Waiver.....	135
27.5.	27.5 Liability for review of Documents and Drawings	136
27.6.	Exclusion of implied warranties etc.	136
27.7.	Survival	136
27.8.	Entire Agreement.....	136
27.9.	Severability	137
27.10.	No partnership.....	137
27.11.	Third parties.....	137
27.12.	Successors and assigns	137
27.13.	Notices.....	137
27.14.	Language.....	138
27.15.	Counterparts.....	138
27.16.	Confidentiality.....	138
27.17.	Copyright and Intellectual Property rights	138

27.18. Limitation of Liability.....	139
27.19. Care and Supply of Documents.....	139
27.20. Authority's Use of Contractor's Documents.....	139
27.21. Contractor's Use of Authority's Documents.....	140
27.22. Access to the Site by Others.....	140
27.23. Term.....	140
27.24. Amendments.....	141
27.25. Representation and Bribes.....	141
27.26. No Agency.....	141
Schedules.....	142
Schedule-A.....	142
Site of the Project.....	142
Annex –I: Site.....	142
Annex – II: Dates for providing Right of Way of Construction Zone.....	142
Annex – IV: Environment Clearances.....	142
Schedule - B.....	142
Development of the Project Highway.....	142
1. Development of the Project Highway.....	142
2. [Rehabilitation and augmentation].....	142
3. Specifications and Standards.....	142
Annex -I : Description of [Two –Laning].....	142
Schedule - C.....	143
Project Facilities.....	143
1. Project Facilities.....	143
2. Description of Project Facilities.....	143
Schedule - D.....	143
Specifications and Standards.....	143
1. Construction.....	143
2. Design Standards.....	143
Annex –I: Specifications and Standards for Construction.....	143
Schedule - E.....	143
Maintenance Requirements.....	143
1. Maintenance Requirements.....	143
2. Repair/rectification of Defects and deficiencies.....	143
3. Other Defects and deficiencies.....	143
4. Extension of time limit.....	143
5. Emergency repairs/restoration.....	143
6. Daily inspection by the Contractor.....	143
7. Pre-monsoon inspection / Post-monsoon inspection.....	143
8. Repairs on account of natural calamities.....	143
Annex –I: Repair/rectification of Defects and deficiencies.....	143
Schedule - F.....	143
Applicable Permits.....	143
1. Applicable Permits.....	143

Schedule - G	143
Annex-I : Form of Bank Guarantee	143
Annex – II: Form for Guarantee for Advance Payment	143
Schedule - H	143
Contract Price Weightages	143
Schedule -I	143
Drawings	143
1. Drawings.....	143
2. Additional Drawings.....	143
Annex –I: List of Drawings	143
Schedule - J	143
Project Completion Schedule	143
1. Project Completion Schedule	143
2. Project Milestone-I.....	143
3. Project Milestone-II.....	143
4. Project Milestone-III.....	143
5. Scheduled Completion Date	143
6. Extension of time	143
Schedule - K	143
Tests on Completion	143
1. Schedule for Tests	143
2. Tests	143
3. Agency for conducting Tests.....	143
4. Completion Certificate	143
Schedule - L	143
Completion Certificate	143
Schedule - M	143
Payment Reduction for Non-Compliance	143
1. Payment reduction for non-compliance with the Maintenance Requirements.....	143
2. Percentage reductions in lump sum payments on monthly basis	143
Schedule - N	143
Selection of Authority's Engineer	143
1. Selection of Authority's Engineer	143
2. Terms of Reference	143
3. Appointment of Government entity as Authority's Engineer	143
Annex –I: Terms of Reference for Authority's Engineer	143
Schedule - O	143
1. Stage Payment Statement for Works	143
2. Monthly Maintenance Payment Statement.....	143
3. Contractor's claim for Damages.....	143
Schedule - P	143
Insurance	143

1.	Insurance during Construction Period	143
2.	Insurance for Contractor's Defects Liability.....	143
3.	Insurance against injury to persons and damage to property.....	143
4.	Insurance to be in joint names	143
Schedule-Q.....		143
1.	Riding Quality test:.....	143
2.	Visual and physical test:	143
Schedule-R.....		143
	Taking Over Certificate	143

Part I
Preliminary

ENGINEERING, PROCUREMENT AND CONSTRUCTION AGREEMENT

THIS AGREEMENT is entered into on this the day of, 20.....

BETWEEN

The President of India through the National Highways and Infrastructure Development Corporation Limited, represented by Managing Director, National Highways & Infrastructural Development Corporation Limited (NHIDCL) and having its principal office at 3rd Floor, PTI Building, 4, Parliament Street New Delhi-110001 (hereinafter referred to as the "**Authority**") which expression shall, unless repugnant to the context or meaning thereof, include its administrators, successors and assigns) of One Part;

AND

{-----,} means the selected bidder having its registered office at, (hereinafter referred to as the "**Contractor**") which expression shall, unless repugnant to the context or meaning thereof, include its successors and permitted assigns) of the Other Part.

WHEREAS:

- (A) The Government of India entrusted to the Authority the development, maintenance and management of National Highway No. 10 including the section from Km 67+080 to Km 67+500 (approximately 0.420 Km.)
- (B) The Authority had resolved to rehabilitate and augment the existing road from Km 67+080 to Km 67+500 (approximately 0.420 Km) on the Singtam to Ranipool section of National Highway No. 10 (hereinafter called the **NH-10**) in the State of Sikkim by 2-Laning on Engineering, Procurement, Construction ("**EPC**") basis in accordance with the terms and conditions to be set forth in an agreement to be entered into.
- (C) The Authority accordingly invited the proposals (the "**Request for Proposals**" or "**RFP**") from the eligible bidders as per the technical and commercial terms and conditions prescribed in the RFP for undertaking the Project.
- (D) After evaluation of the bids received, the Authority accepted the bid of the selected bidder and issued its Letter of Acceptance No _____ dated _____ (hereinafter called the "**LOA**") to the selected bidder for [rehabilitation and augmentation of the above section of [NH-10] at the Contract Price specified hereinafter, requiring the selected bidder to inter alia:
 - (i) to give his consent to enter into this Agreement and the enforceability of the provisions thereof, within 10 (ten) days of the date of issue of LOA;
 - (ii) submit Performance Security and Additional Performance Security (if any) as per RFP requirements, and
 - (iii) execute this Agreement within 30 (thirty) days of the date of issue of LOA.
- (E) The Contractor has fulfilled the requirements specified in Recital (D) above;

NOW, THEREFORE, in consideration of the foregoing and the respective covenants set forth in this Agreement, the sufficiency and adequacy of which is hereby acknowledged, the Authority hereby covenants to pay the Contractor, in consideration of the obligations specified herein, the Contract Price or such other sum as may become payable under the provisions of the Agreement at the times and in the manner specified by the Agreement and intending to be legally bound hereby, the Parties agree as follows:

- (a) Volume-I :
- The Agreement;
 - Corrigendum to the Agreement;
 - Addendum, if any, to RFP;
 - Letter comprising the financial Bid;
 - Letter of Acceptance;
 - Power of Attorney;
 - Joint Venture Agreement, if any;
 - Legal opinion;
 - Any other document to be specified
- (b) Volume-II: Alignment Plans and Drawings; Annex-III of Schedule-A (Alignment Plan); Typical Cross Sections; Layout of Major Junctions; GAD of the bridges; Any other drawings to be specified
- (c) Volume-III: Technical Bid

Article 1

Definitions and Interpretations

1.1. Definitions

- (i) The words and expressions beginning with capital letters and defined in this Agreement shall, unless the context otherwise requires, have the meaning ascribed thereto herein, and the words and expressions defined in the Schedules and used therein shall have the meaning ascribed thereto in the Schedules.
- (ii) In this Agreement, the following words and expressions shall, unless repugnant to the context or meaning thereof, have the meaning hereinafter respectively assigned to them:

"Accounting Year" means the financial year commencing from the first day of April of any calendar year and ending on the thirty-first day of March of the next calendar year;

"Advance Payment" shall have the meaning set forth in Clause 19.2;

"Affected Party" shall have the meaning set forth in Clause 21.1;

"Affiliate" means, in relation to either Party {and/or Members}, a person who controls, is controlled by, or is under the common control with such Party {or Member} (as used in this definition, the expression "control" means, with respect to a person which is a company or corporation, the ownership, directly or indirectly, of more than 50% (fifty per cent) of the voting shares of such person, and with respect to a person which is not a company or corporation, the power to direct the management and policies of such person, whether by operation of law or by contract or otherwise);

"Agreement" means this Agreement, its Recitals, the Schedules hereto and any amendments thereto, or any supplementary agreement made in accordance with the provisions contained in this Agreement;

"Applicable Laws" means all laws, brought into force and effect by the GOI or the State Government including rules, regulations and notifications made there under, and judgements, decrees, injunctions, writs and orders of any court of record, applicable to this Agreement and the exercise, performance and discharge of the respective rights and obligations of the Parties hereunder, as may be in force and effect during the subsistence of this Agreement;

"Applicable Permits" means all clearances, licences, permits, authorisations, no objection certificates, consents, approvals and exemptions required to be obtained or maintained under Applicable Laws in connection with the construction, operation and maintenance of the Project Highway during the subsistence of this Agreement;

"Appointed Date" means the date declared by the Authority as the project commencement date with the consent of the contractor, as per the process prescribed in Article 3 and 8 of this Agreement;

"Arbitration Act" means the Arbitration and Conciliation Act, 1996, with all its subsequent amendments;

"**Authority**" shall have the meaning attributed thereto in the array of Parties hereinabove as set forth in the Recitals;

"**Authority Default**" shall have the meaning set forth in Clause 23.2;

"**Authority's Engineer**" shall have the meaning set forth in Clause 18.1;

"**Authority Representative**" means such person or persons as may be authorised in writing by the Authority to act on its behalf under this Agreement and shall include any person or persons having authority to exercise any rights or perform and fulfil any obligations of the Authority under this Agreement;

"**Bank**" means a bank incorporated in India and recognized by the Reserve Bank of India

"**Base Rate**" means the floor rate of interest announced by the State Bank of India for all its lending operations;

"**Base Date**" means the last date of the calendar month, which precedes the Bid Due Date by at least 28 (twenty eight) days;

"**Bid**" means the documents in their entirety comprised in the bid submitted by the [selected bidder/ Joint venture] in response to the Request for Proposal in accordance with the provisions thereof;

"**Bid Security**" means the bid security provided by the Contractor to the Authority in accordance with the Request for Proposal, and which is to remain in force until substituted by the Performance Security;

"**Change in Law**" means the occurrence of any of the following after the Base Date:

- (a) the enactment of any new Indian law;
- (b) the repeal, modification or re-enactment of any existing Indian law;
- (c) the commencement of any Indian law which has not come into effect until the Base Date; or
- (d) a change in the interpretation or application of any Indian law by a judgement of a court of record which has become final, conclusive and binding, as compared to such interpretation or application by a court of record prior to the Base Date.

"**Change of Scope**" shall have the meaning set forth in Article 13;

"**Change of Scope Notice**" shall have the meaning set forth in Clause 13.2 (i);

"**Change of Scope Request**" shall have the meaning set forth in Clause 13.2 (ii);

"**Change of Scope Order**" shall have the meaning set forth in Clause 13.2 (iv);

"**Completion Certificate**" shall have the meaning set forth in Clause 12.2;

"**Construction**" shall have the meaning set forth in Clause 1.2 (f);

"Construction Period" means the period commencing from the Appointed Date and ending on the date of the Completion Certificate;

"Construction Zone" shall have the meaning set forth in Clause 8.3 (i);

"Contract Price" means the amount specified in Clause 19.1 (i);

"Contractor" shall have the meaning attributed thereto in the array of Parties hereinabove as set forth in the Recitals;

"Contractor Default" shall have the meaning set forth in Clause 23.1;

"Cure Period" means the period specified in this Agreement for curing any breach or default of any provision of this Agreement by the Party responsible for such breach or default and shall:

- (a) commence from the date on which a notice is delivered by one Party to the other Party asking the latter to cure the breach or default specified in such notice;
- (b) not relieve any Party from liability to pay Damages or compensation under the provisions of this Agreement; and
- (c) not in any way be extended by any period of Suspension under this Agreement; provided that if the cure of any breach default by the Contractor requires any reasonable action by the Contractor that must be approved by the Authority or the Authority's Engineer hereunder, the applicable Cure Period shall be extended by the period taken by the Authority or the Authority's Engineer to accord their approval;

"Damages" shall have the meaning set forth in paragraph (w) of Clause 1.2;

"Defect" means any defect or deficiency in Construction of the Works or any part thereof, which does not conform with the Specifications and Standards, and in the case of Maintenance, means any Defect or deficiency which is specified in Schedule-E;

"Defects Liability Period" shall have the meaning set forth in Clause 17.1;

"Dispute" shall have the meaning set forth in Clause 26.1;

"Dispute Resolution Procedure" means the procedure for resolution of Disputes set forth in Article 26;

"Drawings" means all of the drawings, calculations and documents pertaining to the Project Highway as set forth in Schedule-I, and shall include 'as built' drawings of the Project Highway;

"Document" or "Documentation" means documentation in printed or written form, or in tapes, discs, drawings, computer programmes, writings, reports, photographs, films, cassettes, or expressed in any other written, electronic, audio or visual form;

"Emergency" means a condition or situation that is likely to endanger the safety or security of the individuals on or about the Project Highway, including Users thereof, or which poses an immediate

threat of material damage to any of the Project Assets;

"Encumbrances" means, in relation to the Project Highway, any encumbrances such as mortgage, charge, pledge, lien, hypothecation, security interest, assignment, privilege or priority of any kind having the effect of security or other such obligations, and shall include any designation of loss to payees or beneficiaries or any similar arrangement under any insurance policy pertaining to the Project Highway, where applicable herein but excluding utilities referred to in Clause 9.1;

"EPC" means engineering, procurement and construction;

"Final Payment Certificate" shall have the meaning set forth in Clause 19.15;

"Final Payment Statement" shall have the meaning set forth in Clause 19.13;

"Force Majeure" or "Force Majeure Event" shall have the meaning ascribed to it in Clause 21.1;

"GAD" or "General Arrangement Drawings" shall have the meaning set forth in Clause 3.1 (iii) (b);

"GOI" or "Government" means the Government of India;

"Good Industry Practice" means the practices, methods, techniques, designs, standards, skills, diligence, efficiency, reliability and prudence which are generally and reasonably expected from a reasonably skilled and experienced contractor engaged in the same type of undertaking as envisaged under this Agreement and which would be expected to result in the performance of its obligations by the Contractor in accordance with this Agreement, Applicable Laws and Applicable Permits in reliable, safe, economical and efficient manner;

"Government Instrumentality" means any department, division or sub-division of the Government or the State Government and includes any commission, board, authority, agency or municipal and other local authority or statutory body including panchayat under the control of the Government or the State Government, as the case may be, and having jurisdiction over all or any part of the Project Highway or the performance of all or any of the services or obligations of the Contractor under or pursuant to this Agreement;

"Handover Memorandum" shall have the meaning set forth in Clause 8.2;

"IRC" means the Indian Roads Congress;

"Indemnified Party" means the Party entitled to the benefit of an indemnity pursuant to Article 25;

"Indemnifying Party" means the Party obligated to indemnify the other Party pursuant to Article 25;

"Indirect Political Event" shall have the meaning set forth in Clause 21.3;

"Insurance Cover" means the aggregate of the maximum sums insured under the insurance taken out by the Contractor pursuant to Article 20, and includes all insurances required to be taken out by the Contractor under Clauses 20.1 and 20.9 but not actually taken, and when used

in the context of any act or event, it shall mean the aggregate of the maximum sums insured and payable or deemed to be insured and payable in relation to such act or event;

"Intellectual Property" means all patents, trademarks, service marks, logos, get-up, trade names, internet domain names, rights in designs, blue prints, programmes and manuals, drawings, copyright (including rights in computer software), database rights, semi-conductor, topography rights, utility models, rights in know-how and other intellectual property rights, in each case whether registered or unregistered and including applications for registration, and all rights or forms of protection having equivalent or similar effect anywhere in the world;

"Interim Payment Certificate" or **"IPC"** means the interim payment certificate issued by the Authority's Engineer for payment to the Contractor in respect of Contractor's claims for payment raised in accordance with the provisions of this Agreement;

"Joint Venture" means the group of entities which have come together for implementation of this Project;

"Lead Member" shall, in the case of a joint venture, mean the member of such joint venture who shall have the authority to bind the contractor and each member of the Joint venture; and shall be deemed to be the Contractor for the purposes of this Agreement; the Lead Member shall itself undertake and perform at least 51% (fifty one per cent) of the total length of the Project Highway;

"LOA" or **"Letter of Acceptance"** means the letter of acceptance issued by the Authority as referred to in Recital (D);

"Maintenance" means the maintenance of the Project Highway as set forth in Article 14 for the period specified therein;

"Maintenance Inspection Report" shall have the meaning set forth in Clause 15.2;

"Maintenance Manual" shall have the meaning ascribed to it in Clause 10.7;

"Maintenance Programme" shall have the meaning set forth in Clause 14.3;

"Maintenance Period" shall have the meaning set forth in Clause 14.1;

"Maintenance Requirements" shall have the meaning set forth in Clause 14.2;

"Major Bridge" means a bridge having a total length of more than 60 (sixty) metres between the inner faces of the dirt walls as specified in IRC:5;

"Manual" shall mean the Manual of Standards and Specifications for Project Highways;

"Material Adverse Effect" means a material adverse effect of any act or event on the ability of either Party to perform any of its obligations under and in accordance with the provisions of this Agreement and which act or event causes a material financial burden or loss to either Party;

"Materials" comprise of all the supplies used by the Contractor used in the Works or for the maintenance of the Project Highway;

"Monthly Maintenance Statement" shall have the meaning set forth in Clause 19.6;

"MORTH" means the Ministry of Road Transport and Highways or any substitute thereof dealing with Highways;

"Non-Political Event" shall have the meaning set forth in Clause 21.2;

"Parties" means the parties to this Agreement collectively and "Party" shall mean any of the parties to this Agreement individually;

"Performance Security" and **"Additional Performance Security"** shall have the meaning set forth in Clause 7.1;

"Plant" means the apparatus and machinery intended to form or forming part of the works of the Works;

"Political Event" shall have the meaning set forth in Clause 21.4;

"Programme" shall have the meaning set forth in Clause 10.1 (iii);

"Project" means the construction and maintenance of the Project Highway in accordance with the provisions of this Agreement, and includes all works, services and equipment relating to or in respect of the Scope of the Project;

"Project Assets" means all physical and other assets relating to (a) tangible assets such as civil works and equipment including foundations, embankments, pavements, road surface, interchanges, bridges, culverts, road over-bridges, drainage works, traffic signals, sign boards, kilo metre-stones, [toll plaza(s)], electrical systems, communication systems, rest areas, relief centres, maintenance depots and administrative offices; and (b) Project Facilities situated on the Site;

"Project Completion Date" means the date on which the Completion Certificate is issued;

"Project Completion Schedule" means the progressive Project Milestones set forth in Schedule-J for completion of the Project Highway on or before the Scheduled Completion Date;

"Project Facilities" means all the amenities and facilities situated on the Site, as described in Schedule-C;

"Project Highway" means the Site comprising the existing road {, proposed bypasses and tunnels} forming part of [NH-** from km ** to km **] and all Project Assets, and its subsequent development and augmentation in accordance with this Agreement;

"Project Milestone" means the project milestone set forth in Schedule-J;

"Proof Consultant" shall have the meaning set forth in Clause 10.2;

"Quality Assurance Plan" or **"QAP"** shall have the meaning set forth in Clause 11.2;

"Re.", "Rs." or "Rupees" or "Indian Rupees" or "INR" means the lawful currency of the Republic of India;

"Request for Proposals" or "RFP" shall have the meaning set forth in Recital 'C'; **"Retention Money"** shall have the meaning set forth in Clause 7.5;

"Right of Way" means and refers to the total land required and acquired for the project, both in its width and length, together with all way leaves, easements, unrestricted access and other rights of way, howsoever described, necessary for construction and maintenance of the Project Highway in accordance with this Agreement;

"Safety Consultant" shall have the meaning set forth in Clause 10.1; **"Scheduled Completion Date"** shall be the date set forth in Clause 10.3;

"Scheduled Construction Period" means the period commencing from the Appointed Date and ending on Scheduled Completion Date;

"Scope of the Project" shall have the meaning set forth in Clause 2.1; **"Section"** means a part of the Project Highway; **"Site"** shall have the meaning set forth in Clause 8.1;

"Specifications and Standards" means the specifications and standards relating to the quality, quantity, capacity and other requirements for the Project Highway, as set forth in Schedule-D, and any modifications thereof, or additions thereto, as included in the design and engineering for the Project Highway submitted by the Contractor to, and expressly approved by, the Authority;

"Stage Payment Statement" shall have the meaning set forth in Clause 19.4;

"Structures" means an elevated road or a flyover, as the case may be;

"Sub-contractor" means any person or persons to whom a part of the Works or the Maintenance has been subcontracted by the Contractor and the permitted legal successors in title to such person, but not an assignee to such person;

"Suspension" shall have the meaning set forth in Article 22;

"Taking Over Certificate" shall have the meaning set forth in Clause 14.10;

"Taxes" means any Indian taxes including GST, excise duties, customs duties, value added tax, sales tax, local taxes, cess and any impost or surcharge of like nature (whether Central, State or local) on the goods, Materials, equipment and services incorporated in and forming part of the Project Highway charged, levied or imposed by any Government Instrumentality, but excluding any interest, penalties and other sums in relation thereto imposed on any account whatsoever. For the avoidance of doubt, Taxes shall not include taxes on corporate income;

"Termination" means the expiry or termination of this Agreement;

"Termination Notice" means the communication issued in accordance with this Agreement by one Party to the other Party terminating this Agreement;

"Termination Payment" means the amount payable by either Party to the other upon Termination in accordance with Article 23;

"Terms of Reference" or "TOR" shall have the meaning set forth in Clause 18.2;

"Tests" means the tests set forth in Schedule-K to determine the completion of Works in accordance with the provisions of this Agreement;

"Time Extension" shall have the meaning set forth in Clause 10.5;

"User" means a person who travels or intends to travel on the Project Highway or any part thereof in/on any vehicle;

"Valuation of Unpaid works" shall have the meaning set forth in Clause 23.5;

"Works" means all works including survey and investigation, design, engineering, procurement, construction, Plant, Materials, maintenance, temporary works and other things necessary to complete the Project Highway in accordance with this Agreement; and

"WPI" means the wholesale price index for various commodities as published by the Ministry of Commerce and Industry, GOI and shall include any index which substitutes the WPI, and any reference to WPI shall, unless the context otherwise requires, be construed as a reference to the WPI published for the period ending with the preceding month.

1.2. Interpretation

- (i) In this Agreement, unless the context otherwise requires,
 - (a) references to any legislation or any provision thereof shall include amendment or re-enactment or consolidation of such legislation or any provision thereof so far as such amendment or re-enactment or consolidation applies or is capable of applying to any transaction entered into hereunder;
 - (b) references to laws of India or Indian law or regulation having the force of law shall include the laws, acts, ordinances, rules, regulations, bye laws or notifications which have the force of law in the territory of India and as from time to time may be amended, modified, supplemented, extended or re-enacted;
 - (c) references to a "person" and words denoting a natural person shall be construed as a reference to any individual, firm, company, corporation, society, trust, government, state or agency of a state or any association or partnership (whether or not having separate legal personality) of two or more of the above and shall include successors and assigns;
 - (d) the table of contents, headings or sub-headings in this Agreement are for convenience of reference only and shall not be used in, and shall not affect, the construction or interpretation of this Agreement;
 - (e) the words "include" and "including" are to be construed without limitation and shall be deemed to be followed by "without limitation" or "but not limited to" whether or not they are followed by such phrases;
 - (f) references to "construction" or "building" include, unless the context otherwise requires, survey and investigation, design, developing, engineering, procurement, supply of plant, materials, equipment, labour, delivery,

transportation, installation, processing, fabrication, testing, and commissioning of the Project Highway, including maintenance during the Construction Period, removing of defects, if any, and other activities incidental to the construction and "construct" or "build" shall be construed accordingly;

- (g) references to "development" include, unless the context otherwise requires, construction, renovation, refurbishing, augmentation, up-gradation and other activities incidental thereto during the Construction Period, and "develop" shall be construed accordingly;
- (h) any reference to any period of time shall mean a reference to that according to Indian standard time;
- (i) any reference to day shall mean a reference to a calendar day;
- (j) references to a "business day" shall be construed as a reference to a day (other than a Sunday) on which banks in Delhi are generally open for business;
- (k) any reference to month shall mean a reference to a calendar month as per the Gregorian calendar;
- (l) references to any date, period or Project Milestone shall mean and include such date, period or Project Milestone as may be extended pursuant to this Agreement;
- (m) any reference to any period commencing "from" a specified day or date and "till" or "until" a specified day or date shall include both such days or dates; provided that if the last day of any period computed under this Agreement is not a business day, then the period shall run until the end of the next business day;
- (n) the words importing singular shall include plural and vice versa;
- (o) references to any gender shall include the other and the neutral gender;
- (p) "lakh" means a hundred thousand (100,000) and "crore" means ten million (10,000,000);
- (q) "indebtedness" shall be construed so as to include any obligation (whether incurred as principal or surety) for the payment or repayment of money, whether present or future, actual or contingent;
- (r) References to the "winding-up", "dissolution", "insolvency" ,or "reorganisation" of a company or corporation shall be construed so as to include any equivalent or analogous proceedings under the law of the jurisdiction in which such company or corporation is incorporated or any jurisdiction in which such company or corporation carries on business including the seeking of liquidation, winding-up, reorganisation, dissolution, arrangement, protection or relief of debtors;

- (s) save and except as otherwise provided in this Agreement, any reference, at any time, to any agreement, deed, instrument, licence or document of any description shall be construed as reference to that agreement, deed, instrument, licence or other document as amended, varied, supplemented, modified or suspended at the time of such reference; provided that this Clause shall not operate so as to increase liabilities or obligations of the Authority hereunder or pursuant hereto in any manner whatsoever;
 - (t) any agreement, consent, approval, authorisation, notice, communication, information or report required under or pursuant to this Agreement from or by any Party or the Authority's Engineer shall be valid and effective only if it is in writing under the hand of a duly authorised representative of such Party or the Authority's Engineer, as the case may be, in this behalf and not otherwise;
 - (u) the Schedules and Recitals to this Agreement form an integral part of this Agreement and will be in full force and effect as though they were expressly set out in the body of this Agreement;
 - (v) references to Recitals, Articles, Clauses, Sub-clauses or Schedules in this Agreement shall, except where the context otherwise requires, mean references to Recitals, Articles, Clauses, Sub-clauses and Schedules of or to this Agreement, and references to a Paragraph shall, subject to any contrary indication, be construed as a reference to a Paragraph of this Agreement or of the Schedule in which such reference appears;
 - (w) the damages payable by either Party to the other of them, as set forth in this Agreement, whether on per diem basis or otherwise, are mutually agreed genuine pre-estimated loss and damage likely to be suffered and incurred by the Party entitled to receive the same and are not by way of penalty or liquidated damages (the "Damages"); and
 - (x) time shall be of the essence in the performance of the Parties' respective obligations. If any time period specified herein is extended for the reasons specified in the Agreement, such extended time shall also be of the essence.
- (ii) Unless expressly provided otherwise in this Agreement, any Documentation required to be provided or furnished by the Contractor to the Authority shall be provided free of cost and in three copies, and if the Authority is required to return any such Documentation with its comments and/or approval, it shall be entitled to retain two copies thereof.
 - (iii) The rule of construction, if any, that a contract should be interpreted against the parties responsible for the drafting and preparation thereof, shall not apply.
 - (iv) Any word or expression used in this Agreement shall, unless otherwise defined or construed in this Agreement, bear its ordinary English meaning and, for these purposes, the General Clauses Act, 1897 shall not apply.

1.3. Measurements and arithmetic conventions

All measurements and calculations shall be in the metric system and calculations done to 2

(two) decimal places, with the third digit of 5 (five) or above being rounded up and below 5 (five) being rounded down.

1.4. Priority of agreements and errors/discrepancies

- (i) This Agreement, and all other agreements and documents forming part of or referred to in this Agreement are to be taken as mutually explanatory and, unless otherwise expressly provided elsewhere in this Agreement, the priority of this Agreement and other documents and agreements forming part hereof or referred to herein shall, in the event of any conflict between them, be in the following order:
 - (a) this Agreement; and
 - (b) all other agreements and documents forming part hereof or referred to herein; i.e. this Agreement at (a) above shall prevail over the agreements and documents at (b).
- (ii) Subject to the provisions of Clause 1.4 (i), in case of ambiguities or discrepancies within this Agreement, the following shall apply:
 - (a) between two or more Clauses of this Agreement, the provisions of a specific Clause relevant to the issue under consideration shall prevail over those in other Clauses;
 - (b) between the Clauses of this Agreement and the Schedules, the Clauses shall prevail and between Schedules and Annexes, the Schedules shall prevail;
 - (c) between any two Schedules, the Schedule relevant to the issue shall prevail;
 - (d) between the written description on the Drawings and the Specifications and Standards, the latter shall prevail;
 - (e) between the dimension scaled from the Drawing and its specific written dimension, the latter shall prevail; and
 - (f) between any value written in numerals and that in words, the latter shall prevail.

1.5. Joint and several liability

- (i) If the Contractor has formed a Joint Venture of two or more persons for implementing the Project:
 - (a) these persons shall, without prejudice to the provisions of this Agreement or any other agreement, be deemed to be jointly and severally liable to the Authority for the performance of the Agreement; and
 - (b) the Contractor shall ensure that no change in the composition of the Joint Venture is effected without the prior consent of the Authority.
- (ii) Without prejudice to the joint and several liability of all the members of the Joint Venture, the Lead Member represent all the members of the Joint Venture and shall

always be liable and responsible for discharging the functions and obligations of the Contractor. The Contractor shall ensure that each member of the Joint Venture shall be bound by any decision, communication, notice, action or inaction of the Lead Member on any matter related to this Agreement and the Authority shall be entitled to rely upon any such action, decision or communication of the Lead Member. The Authority shall have the right to release payments solely to the Lead Member and shall not in any manner be responsible or be held liable for the inter se allocation of payments among members of the Joint venture.¹

¹ This Clause 1.5 may be omitted if the Contractor is not a Joint venture. Even if the Contractor is a Joint venture, the Authority may, at its discretion, delete this provision.

Part II
Scope of Project

Article 2

Scope of the Project

2.1. Scope of the Project

Under this Agreement, the scope of the Project (the "**Scope of the Project**") shall mean and include:

- (a) construction of the Project Highway on the Site set forth in Schedule- A and as specified in Schedule-B together with provision of Project Facilities as specified in Schedule-C, and in conformity with the Specifications and Standards set forth in Schedule-D;
- (b) maintenance of the Project Highway in accordance with the provisions of this Agreement and in conformity with the requirements set forth in Schedule-E; and
- (c) performance and fulfillment of all other obligations of the contractor in accordance with the provisions of this Agreement and matters incidental thereto or necessary for the performance of any or all of the obligations of the Contractor under this Agreement.

Article 3

Obligations of the Authority

3.1. Obligations of the Authority

- (i) The Authority shall, at its own cost and expense, undertake, comply with and perform all its obligations set out in this Agreement or arising hereunder.
- (ii) The Authority shall be responsible for the correctness of the Scope of the Project, Project Facilities, Specifications and Standards and the criteria for testing of the completed Works.
- (iii) The Authority shall, upon submission of the Performance Security as per the RFP by the Contractor, shall provide to the Contractor:
 - (a) No less than 90% (ninety per cent) of the required Right of Way of the Construction Zone of total length of the Project Highway within a period of 30 (thirty) days from the date of this Agreement, which shall be in contiguous stretches of length not less than 5 (five) kilometre.
 - (b) approval of the general arrangement drawings (the "GAD") from railway authorities to enable the Contractor to construct road over- bridges/ under-bridges at level crossings on the Project Highway in accordance with the Specifications and Standards, and subject to the terms and conditions specified in such approval, within a period of 60 (sixty) days from the Appointed Date, and reimbursement of all the costs and expenses paid by the Contractor to the railway authorities for and in respect of the road over-bridges/ under bridges; and
 - (c) all environmental clearances as required under Clause 4.3.
- (iv) Delay in providing the Right of Way or approval of GAD by railway authorities, as the case may be, in accordance with the provisions of Clause 3.1 (iii) shall entitle the Contractor to Damages in a sum calculated in accordance with the provisions of Clause 8.3 of this Agreement and Time Extension in accordance with the provisions of Clause 10.5 of this Agreement. For the avoidance of doubt, the Parties agree that the Damages for delay in approval of GAD by the railway authorities for a particular road over-bridge/ under-bridge shall be deemed to be equal to the Damages payable under the provisions of Clause 8.3 for delay in providing Right of Way for a length of 2 (two) kilometre for each such road over-bridge/ under-bridge.
- (v) Notwithstanding anything to the contrary contained in this Agreement, the Parties expressly agree that the aggregate Damages payable under Clauses 3.1 (iv), 8.3 and 9.5 shall not exceed 1% (one per cent) of the Contract Price. For the avoidance of doubt, the damages payable by the Authority under the aforesaid Clauses shall not be additive if they arise concurrently from more than one cause but relate to the same part of the Project Highway.

Both the parties agree that payment of such Damages shall be full and final settlement of all claims of the Contractor and such compensation shall be the sole remedy against delays of the Authority and both parties further agree that the payment of Damages shall be the final cure for the Contractor against delays of the Authority, without recourse to any other payments.

- (vi) The Authority agrees to provide support to the Contractor and undertakes to observe, comply with and perform, subject to and in accordance with the provisions of this Agreement and the Applicable Laws, the following:
- (a) upon written request from the Contractor, and subject to the Contractor complying with Applicable Laws, provide reasonable support to the Contractor in procuring Applicable Permits required from any Government Instrumentality for implementation of the Project;
 - (b) upon written request from the Contractor, provide reasonable assistance to the Contractor in obtaining access to all necessary infrastructure facilities and utilities, including water and electricity at rates and on terms no less favourable than those generally available to commercial customers receiving substantially equivalent services;
 - (c) procure that no barriers that would have a material adverse effect on the works are erected or placed on or about the Project Highway by any Government Instrumentality or persons claiming through or under it, except for reasons of Emergency, national security, law and order or collection of inter-state taxes;
 - (d) not do or omit to do any act, deed or thing which may in any manner violate any provisions of this Agreement;
 - (e) support, cooperate with and facilitate the Contractor in the implementation of the Project in accordance with the provisions of this Agreement; and
 - (f) upon written request from the Contractor and subject to the provisions of Clause 4.3, provide reasonable assistance to the Contractor and any expatriate personnel of the Contractor or its Sub-contractors to obtain the applicable visas and the requisite work permits for the purposes of discharge by the Contractor or its Sub-contractors of their obligations under this Agreement and the agreements with the Sub-contractors.

3.2 Maintenance obligations prior to the Appointed Date

The Authority shall, prior to the Appointed Date, maintain the Project Highway, at its own cost and expense, so that its traffic worthiness and safety are at no time materially inferior as compared to its condition 10 (ten) days prior to the last date for submission of the Bid, and in the event of any material deterioration or damage other than normal wear and tear, undertake repair thereof. For the avoidance of doubt, the Authority shall undertake only routine maintenance prior to the Appointed Date, and it shall undertake special repairs only in the event of excessive deterioration or damage caused due to unforeseen events such as floods or earthquake.

3.3 Environmental Clearances

The Authority represents and warrants that the environmental clearances required for construction of the Project shall be procured by the Authority prior to the date of issue of LOA. For the avoidance of doubt, the present status of environmental clearances is specified in Schedule-A.

3.4 Deemed Termination upon delay

Without prejudice to the provisions of Clause 8.3, and subject to the provisions of Clause 7.3, the Parties expressly agree that in the event the Appointed Date does not occur, for any reason whatsoever, within 90 days of signing of the Agreement and submission of the full Performance Security by the Contractor, the Agreement shall be deemed to have been terminated. The Authority shall pay damages to the Contractor equivalent to 1% of the Contract Price (3% in case of standalone bridge projects). All other rights, privileges, claims and entitlements of the Contractor under or arising out of this Agreement shall be deemed to have been waived by, and to have ceased. The Contractor shall hand over all information in relation to the Highway, including but not limited to any data, designs, drawings, structures, information, plans, etc. prepared by them for the Highway, to the Authority.

Article 4

Obligations of the Contractor

4.1. Obligations of the Contractor

- (i) Subject to and on the terms and conditions of this Agreement, the Contractor shall undertake the survey, investigation, design, engineering, procurement, construction, and maintenance of the Project Highway and observe, fulfil, comply with and perform all its obligations set out in this Agreement or arising hereunder.
- (ii) The Contractor shall comply with all Applicable Laws and Applicable Permits (including renewals as required) in the performance of its obligations under this Agreement.
- (iii) Subject to the provisions of Clauses 4.1 (i) and 4.1 (ii), the Contractor shall discharge its obligations in accordance with Good Industry Practice and as a reasonable and prudent person.
- (iv) The Contractor shall remedy any and all loss, defects, or damage to the Project Highway from the Appointed Date until the end of the Construction Period at the Contractor's cost, save and except to the extent that any such loss, defect, or damage shall have arisen from any wilful default or neglect of the Authority.
- (v) The Contractor shall remedy any and all loss, defect or damage to the Project Highway during the Defects Liability Period at the Contractor's cost to the extent that such loss, defect or damage shall have arisen out of the reasons specified in Clause 17.3.
- (vi) The Contractor shall remedy any and all loss or damage to the Project Highway during the Maintenance Period at the Contractor's cost, including those stated in Clause 14.1 (ii), save and except to the extent that any such loss or damage shall have arisen on account of any wilful default or neglect of the Authority or on account of a Force Majeure Event.
- (vii) The Contractor shall, at its own cost and expense, in addition to and not in derogation of its obligations elsewhere set out in this Agreement:
 - (a) make, or cause to be made, necessary applications to the relevant Government Instrumentalities with such particulars and details as may be required for obtaining Applicable Permits set forth in Schedule-F and obtain and keep in force and effect such Applicable Permits in conformity with the Applicable Laws;
 - (b) procure, as required, the appropriate proprietary rights, licences, agreements and permissions for Materials, methods, processes and systems used or incorporated into the Project Highway;
 - (c) make reasonable efforts to maintain harmony and good industrial relations among the personnel employed by it or its Sub-contractors in connection with the performance of its obligations under this Agreement;

- (d) ensure and procure that its Sub-contractors comply with all Applicable Permits and Applicable Laws in the performance by them of any of the Contractor's obligations under this Agreement;
 - (e) not do or omit to do any act, deed or thing which may in any manner violate any provisions of this Agreement;
 - (f) support, cooperate with and facilitate the Authority in the implementation and operation of the Project in accordance with the provisions of this Agreement;
 - (g) ensure that the Contractor and its Sub-contractors comply with the safety and welfare measures for labour in accordance with the Applicable Laws and Good Industry Practice;
 - (h) keep, on Site, a copy of this Agreement, publications named in this Agreement, the Drawings, Documents relating to the Project, and Change of Scope orders and other communications given under this Agreement. The Authority's Engineer and its authorised personnel shall have the right of access to all these documents at all reasonable times;
 - (i) cooperate with other contractors employed by the Authority and personnel of any public authority; and
 - (j) not interfere unnecessarily or improperly with the convenience of the public, or the access to and use and occupation of all roads and footpaths, irrespective of whether they are public or in the possession of the Authority or of others.
- (viii) The Contractor shall undertake all necessary superintendence to plan, arrange, direct, manage, inspect and test the Works. The Contractor shall provide all necessary superintendence of the Works for the proper fulfilling of the Contractor's obligations under the Agreement. Such superintendence shall be given by competent person having adequate knowledge of the operations to be carried out (including the methods and techniques required, the hazards likely to be encountered and methods of preventing accidents) for the satisfactory and safe execution of the Works.
- (ix) The Contractor shall obtain and maintain a project related bank account operational at site where all transactions related to the payment of work will be done. The Contractor shall submit a monthly account statement and a detailed report on utilization of funds transferred to this project related bank account to Authority's Engineer. Notwithstanding anything contrary to this agreement, the authority, in the interest and to ensure timely completion of the work, reserves the right to audit such bank accounts to ensure that there is no diversion of funds from this project specific account to any other project being implemented by the Contractor.
- (x) The Contractor shall provide the documents of the Contractor specified in the Agreement, and all Contractors' personnel; Goods, consumables and other things and services, whether of a temporary or permanent nature, required in and for the execution, completion of Works and remedying defects.

- (xi) The Contractor shall perform the Works in conformity with the Project requirements and other requirements and standards prescribed under or pursuant to the Agreement.
- (xii) The Contractor shall carry out such work incidental and contingent to the original Scope of the Project to comply with Good Industry Practices.
- (xiii) The Contractor shall maintain required staff and necessary Contractor's equipment and materials within the reach of the Site during the Defects Liability Period so that any defects arising are promptly attended.

4.2. Obligations relating to sub-contracts and any other agreements

- (i) The Contractor, whether Joint Venture or sole, shall not sub-contract any Works in more than **49% (forty nine per cent)** of the Contract Price and shall carry out Works directly under its own supervision and through its own personnel and equipment in **at least 51% (fifty one per cent)** of the Contract Price. Further, in case the Contractor is a Joint Venture, then the Lead Member shall carry out Works directly through its own resources (men, material and machines etc.) in **at least 51% (fifty one per cent)** of total length of the Project Highway. Provided, however, that in respect of the Works carried out directly by the Contractor, it may enter into contracts for the supply and installation of Materials, Plant, equipment, road furniture, safety devices and labour, as the case may be, for such Works. For the avoidance of doubt, the Parties agree that the Contractor may sub-divide the aforesaid length of **51% (fifty one per cent)** in no more than 5 (five) sections of the Project Highway. The Parties further agree that all obligations and liabilities under this Agreement for the entire project Highway shall at all times remain with the Contractor.
- (ii) In the event any sub-contract for Works, or the aggregate of such sub-contracts with any Sub-contractor, exceeds 5% (five percent) of the Contract Price, the Contractor shall communicate the name and particulars, including the relevant experience of the Sub-contractor, to the Authority prior to entering into any such sub-contract. The Authority shall examine the particulars of the Sub- contractor from the national security and public interest perspective and may require the Contractor, no later than 15 (fifteen) business days from the date of receiving the communication from the Contractor, not to proceed with the sub-contract, and the Contractor shall comply therewith.
- (iii) In the event any sub-contract referred to in Clause 4.2 (ii) relates to a Sub- contractor who has, over the preceding 3 (three) years, not undertaken at least one work of a similar nature with a contract value exceeding 40% (forty per cent) of the value of the sub-contract to be awarded hereunder, and received payments in respect thereof for an amount equal to at least such 40% (forty per cent), the Authority may, no later
- (iv) than 15 (fifteen) business days from the date of receiving the communication from the Contractor, require the Contractor not to proceed with such sub-contract, and the Contractor shall comply therewith without delay or demur.
- (v) It is expressly agreed that the Contractor shall, at all times, be responsible and liable for all its obligations under this Agreement notwithstanding anything contained in the agreements with its Sub-contractors or any other agreement that may be entered into by

the Contractor, and no default under any such agreement shall excuse the Contractor from its obligations or liability under this Agreement. However, in case of non-compliance of the Contractor towards his obligations for payments to the approved Sub-contractor(s), which is likely to affect the progress of works, the authority reserves the right to intervene and direct the Contractor to release such outstanding payments to approved Sub-contractor(s) out of the payments due for the completed Works in the interest of work.

4.3. Employment of foreign nationals

The Contractor acknowledges, agrees and undertakes that employment of foreign personnel by the Contractor and/or its Sub-contractors and their sub- contractors shall be subject to grant of requisite regulatory permits and approvals including employment/ residential visas and work permits, if any required, and the obligation to apply for and obtain the same shall always rest with the Contractor. Notwithstanding anything to the contrary contained in this Agreement, refusal of or inability to obtain any such permits and approvals by the Contractor or any of its Subcontractors or their sub-contractors shall not constitute a Force Majeure Event, and shall not in any manner excuse the Contractor from the performance and discharge it of its obligations and liabilities under this Agreement, and the Contractor's liabilities hereunder shall remain unaffected by such failure, refusal or inability.

4.4. Contractor's personnel

- (i) The Contractor shall ensure that the personnel engaged by it or by its Subcontractors in the performance of its obligations under this Agreement are at all times appropriately and adequately qualified, skilled and experienced in their respective functions in conformity with Good Industry Practice. The Contractor will try to hire at least 10% (ten percent) trained workmen as per the National Skills Qualifications Framework. If necessary, the requisite workmen may be got trained by the Contractor at his cost through authorized training centres of the Directorate General of Training (DGT). The Contractor will organize training at project site/ sites for the trainees as and when required as per the training schedule finalized in consultation with the training centres. The trainees shall be paid stipend by the Contractor (subject to a maximum of Rs. 15,000/- per person) on the basis of minimum wages to compensate for loss of income during the training period.
- (ii) The Authority's Engineer may, for reasons to be specified in writing, direct the Contractor to remove any member of the Contractor's or Sub-contractor's personnel. Provided that any such direction issued by the Authority's Engineer shall specify the reasons for the removal of such person.
- (iii) The Contractor shall on receiving such a direction from the Authority's Engineer order for the removal of such person or persons with immediate effect. It shall be the duty of the Contractor to ensure that such persons are evicted from the Site within 10 (ten) days of any such direction being issued in pursuance of Clause 4.4 (ii). The Contractor shall further ensure that such persons have no further connection with the Works or Maintenance under this Agreement. The Contractor shall then appoint (or cause to be appointed) a replacement.

4.5. Advertisement on Project Highway

The Project Highway or any part thereof shall not be used in any manner to advertise any commercial product or services.

4.6. Contractor's care of the Works

The Contractor shall bear full risk in, and take full responsibility for, the care of the Works, and of the Materials, goods and equipment for incorporation therein, from the Appointed Date until the date of Completion Certificate, save and except to the extent that any such loss or damage shall have arisen from any wilful default or gross neglect of the Authority.

4.7. Electricity, water and other services

The Contractor shall be responsible for procuring of all utilities as may be required, including without limitation, adequate power, water and other services.

4.8. Unforeseeable difficulties

Except as otherwise stated in the Agreement:

- (a) the Contractor accepts complete responsibility for having foreseen all difficulties and costs of successfully completing the Works;
- (b) the Contract Price shall not be adjusted to take account of any unforeseen difficulties or costs; and
- (c) the Scheduled Completion Date shall not be adjusted to take account of any unforeseen difficulties or costs.

4.9. Co-ordination of the Works

- (i) The Contractor acknowledges that in addition to the Agreement, it is also aware of terms of the other Project contracts and other agreements the Authority has negotiated and entered into for performance of its obligations under the Agreement (copies of other contracts and other agreements are made available to the Contractor from time to time) and that the Contractor is fully aware of the consequences to the Authority which would or are likely to result from a breach by the Contractor of its obligations under the Agreement. In the event the actions of the Contractor result in the breach by the Authority of any or all of the other Project contracts and such breach imposes any liability on the Authority, the Contractor shall: (a) undertake all steps as may be possible to mitigate or neutralize the liability that has arisen, and (b) indemnify the Authority against any such liability and compensate the Authority to that extent.
- (ii) The Contractor shall be responsible for the co-ordination and proper provision of the Works, including co-ordination of other Contractors or Sub-contractors for the Project. The Contractor shall co-operate with the Authority in the co-ordination of the Works with the works under the other Project contracts. The Contractor shall provide all reasonable support for carrying out their work to:

- (a) any other contractors employed by the Authority;
- (b) the workmen of the Authority;
- (c) the workmen of any Governmental Instrumentality who may be employed in the execution of work on or near the Site; and
- (d) such other persons as is required in the opinion of the Authority for successful completion of the Project.

4.10. Environmental Measures

- (i) The Contractor agrees to conduct its activities in connection with the Agreement in such a manner so as to comply with the environmental requirements which includes, inter alia, all the conditions required to be satisfied under the environmental clearances and applicable law, and assumes full responsibility for measures which are required to be taken to ensure such compliance.

4.11. Site Data

- (i) The Contractor shall be deemed to have inspected and examined the Site and its surroundings and to have satisfied himself before entering into the Agreement in all material respects including but not limited to:
 - (a) the form and nature of the Site (including, inter-alia, the surface and sub-surface conditions and geo-technical factors);
 - (b) the hydrological and climatic conditions;
 - (c) the extent and nature of the works already completed and Materials necessary for the execution and completion of the Works and the remedying of any defects that includes already executed part also.
 - (d) the suitability and the adequacy of the Site for the execution of the Works;
 - (e) the means of access to the Site and the accommodation the Contractor may require;
 - (f) arranging permits as required as per [.] of the Agreement.
 - (g) the requirements of operation and maintenance; and
 - (h) all other factors and circumstances affecting the Contractor's rights and obligations under the Agreement, the Contract Price and Time for Completion.

4.12. Sufficiency of Contract Price

The Contractor shall have satisfied itself as to the correctness and sufficiency of the Contract Price. The Contract Price shall cover all its obligations under the Agreement, in addition to all risks the Contractor has agreed to undertake under the Agreement, including those associated with the

performance of its obligations under the Agreement and all things necessary for the provision of the Works in a manner satisfactory to the Authority and in accordance with this Agreement.

4.13. Clearance of the Site

During the provision of the Works, and as a pre-condition to the issue of the Taking-Over Certificate, the Contractor shall clear away and remove from the Site, all Contractor's equipment, surplus material, wreckage, rubbish and temporary Works, and shall keep the Site free from all unnecessary obstructions, and shall not store or dispose of any Contractor's equipment or surplus materials on the Site. The Contractor shall promptly clear away and remove from the Site any wreckage, rubbish or temporary Works no longer required and leave the Site and the Works in a clean and safe condition to the sole satisfaction of the Authority.

Article 5

Representations and Warranties

5.1. Representations and warranties of the Contractor

- (i) The Contractor represents and warrants to the Authority that:
 - (a) it is duly organised and validly existing under the laws of India, and has full power and authority to execute and perform its obligations under this Agreement and to carry out the transactions contemplated hereby;
 - (b) it has taken all necessary corporate and/or other actions under Applicable Laws to authorise the execution and delivery of this Agreement and to validly exercise its rights and perform its obligations under this Agreement;
 - (c) this Agreement constitutes its legal, valid and binding obligation, enforceable against it in accordance with the terms hereof, and its obligations under this Agreement will be legally valid, binding and enforceable against it in accordance with the terms hereof;
 - (d) it is subject to the laws of India, and hereby expressly and irrevocably waives any immunity in any jurisdiction in respect of this Agreement or matters arising there under including any obligation, liability or responsibility hereunder;
 - (e) the information furnished in the Bid, Request for Qualification and Request for Proposals or otherwise and as updated on or before the date of this Agreement is true and accurate in all respects as on the date of this Agreement;
 - (f) the execution, delivery and performance of this Agreement will not conflict with, or result in the breach of, or constitute a default under, or accelerate performance required by any of the terms of its memorandum and articles of association or any Applicable Laws or any covenant, contract, agreement, arrangement, understanding, decree or order to which it is a party or by which it or any of its properties or assets is bound or affected;
 - (g) there are no actions, suits, proceedings, or investigations pending or, to its knowledge, threatened against it at law or in equity before any court or before any other judicial, quasi-judicial or other authority, the outcome of which may result in the breach of this Agreement or which individually or in the aggregate may result in any material impairment of its ability to perform any of its obligations under this Agreement;
 - (h) it has no knowledge of any violation or default with respect to any order, writ, injunction or decree of any court or any legally binding order of any Government Instrumentality which may result in any material adverse effect on its ability to perform its obligations under this Agreement and no fact or circumstance exists which may give rise to such proceedings that would adversely affect the performance of its obligations under this Agreement;

- (i) it has complied with Applicable Laws in all material respects and has not been subject to any fines, penalties, injunctive relief or any other civil or criminal liabilities which in the aggregate have or may have a material adverse effect on its ability to perform its obligations under this Agreement;
 - (j) no representation or warranty by it contained herein or in any other document furnished by it to the Authority or to any Government Instrumentality in relation to Applicable Permits contains or will contain any untrue or misleading statement of material fact or omits or will omit to state a material fact necessary to make such representation or warranty not misleading;
 - (k) no sums, in cash or kind, have been paid or will be paid, by it or on its behalf, to any person by way of fees, commission or otherwise for securing the contract or entering into this Agreement or for influencing or attempting to influence any officer or employee of the Authority in connection therewith;
 - (l) nothing contained in this Agreement shall create any contractual relationship or obligation between the Authority and any Sub- contractors, designers, consultants or agents of the Contractor;
 - (m) it is adequately financed has the requisite knowledge, expertise, technical know-how, experience, resources, infrastructure, licenses, patents, copy rights, for designing, supplying/ procuring the goods and materials, and for providing the installation and construction services required for completing the construction of the Project Facilities; and
- (ii) it represents the Authority that:
- (a) it owns or has the right to use all "Intellectual Property" necessary to perform the contractual obligations and to carry on the Works without conflict with the right of others;
 - (b) All intellectual property rights necessary to perform the contractual obligations and to carry on the Works are in full force and effect and are vested in, and beneficially owned by the Contractor, and are free from encumbrances.
 - (c) None of the intellectual property rights is being used, claimed, or posed or attacked by any other person, nor does the use of such intellectual property rights or any part of them infringe the intellectual property rights owned or enjoyed by any third party.
 - (d) None of the intellectual property rights owned or used by the Contractor is the subject of any claim, opposition, attack, assertion or other arrangement of whatsoever nature which does or may impinge upon their use, validity, enforceability or ownership by the Parties, and there are no grounds or other circumstances which may give rise to the same.
 - (e) No licenses or registered user or other rights have been granted or agreed to be granted to any third party in respect of such intellectual property rights.

- (f) No act has been done or has been omitted to be done to entitle any authority or person to cancel, forfeit or modify any intellectual property rights.
 - (g) The Contractor shall notify the Authority of any adverse use of the intellectual property rights or confusingly or deceptively similar to the intellectual property rights.
 - (h) The Contractor shall recognize the Authority's ownership and title to the intellectual property rights and shall not at any time, either directly or indirectly, put to issue the validity or ownership of the intellectual property rights and it will not do any act or thing, either directly or indirectly, which in anyway impairs the validity and ownership of the intellectual property rights.
 - (i) The Contractor shall, promptly execute, acknowledge and deliver all documents which are requested by Authority to record with appropriate governmental agencies and authorities the fact that the Authority has the right to the use of the said intellectual property rights.
 - (j) The Contractor shall not, for any reason, object to, or interfere in any way with the ownership, registration or use of the intellectual property rights by the Authority (or its licensee or assigns) for any purpose whatsoever.
- (iii) The Contractor is fully aware that the Agreement is inter linked with the other Project contracts and the non-performance or deficient performance or default by the Contractor and/or any of the Contractor's personnel or Subcontractors under one among the said contracts will have bearing on the other contracts and the evaluation of the Contractor's performance under the Agreement and the Project itself.
- (iv) If at any time during the Defects Liability Period any item of the Works or Project Facilities or any part thereof, do not conform to the Authority requirements and Specifications and Standards, on being so notified by the Authority, the Contractor shall promptly rectify/remedy such nonconformity to the satisfaction of the Authority solely at the Contractor's expense; failing which the Authority may reject or revoke Taking-Over Certificate, and the Authority may proceed to correct the Contractor's nonconforming Work by the most expeditious means available, the costs of which shall be to the Contractor's account; or the Authority may retain the non-conforming Work and an equitable adjustment reducing the total Contract Price to reflect the diminished value of such non-conforming Work will be made by written amendment.
- (v) In addition to the other warranties, the Contractor represents and warrants as follows:
- (a) The Contractor has (or, if the technology does not currently exist, will have granted at the time of passing to The Employer) in and to the technology used in the equipment, materials, goods, Works, Contractor's documents, Drawings and Manuals ("Technology") -
 - i. all right, title and interest free of any lien, claim or restriction; and
 - ii. right to grant to the Authority the right to use the Technology for the purpose of this contract, free of any lien, claim or restriction and on the terms of license

as required.

- (b) The Contractor has granted (or, if the technology does not currently exist, will grant at the time of passing to the Authority the property and title in and to the equipment, materials, goods, Works, spares, Contractor's documents, Drawings and Manuals in which it is used) to the Authority the right to use the Technology, free of any lien, claim or restriction.
- (vi) In addition to the other Warranties, the Contractor represents and warrants as follows:
 - (a) No Technology contains any worm (i.e., a program that travels from one computer to another computer but does not attach itself to the operating system of the computer it enters), virus (i.e., a program that travels from one computer to another computer that attaches itself to the operating system it enters) or self-destruct capability.
 - (b) The Technology will not abnormally end or provide invalid or incorrect results as a result of date-dependent data.
 - (c) The Technology can accurately recognize, manage, accommodate, and manipulate date-dependent data, including single and multi-century formulas and leap years.
- (vii) No criminal proceedings instituted against any of the employees or Directors of the Contractor.
- (viii) Till date the services of the Contractor has not been terminated by any person for any breach or non-performance or negligence by the Contractor.

5.2. Representations and warranties of the Authority

The Authority represents and warrants to the Contractor that:

- (a) it has full power and authority to execute, deliver and perform its obligations under this Agreement and to carry out the transactions contemplated herein and that it has taken all actions necessary to execute this Agreement, exercise its rights and perform its obligations, under this Agreement;
- (b) it has taken all necessary actions under the Applicable Laws to authorise the execution, delivery and performance of this Agreement;
- (c) it has the financial standing and capacity to perform its obligations under this Agreement;
- (d) this Agreement constitutes a legal, valid and binding obligation enforceable against it in accordance with the terms hereof;
- (e) it has no knowledge of any violation or default with respect to any order, writ, injunction or any decree of any court or any legally binding order of any Government Instrumentality which may result in any material adverse effect on

the Authority's ability to perform its obligations under this Agreement;

- (f) it has complied with Applicable Laws in all material respects;
- (g) it has good and valid right to the Site and has the power and authority to grant the Right of Way in respect thereof to the Contractor; and
- (h) it has procured Right of Way and environment clearances such that the Contractor can commence construction forthwith on 90% (ninety per cent) of the total length of the Project Highway.

5.3. Disclosure

In the event that any occurrence or circumstance comes to the attention of either Party that renders any of its aforesaid representations or warranties untrue or incorrect, such Party shall immediately notify the other Party of the same. Such notification shall not have the effect of remedying any breach of the representation or warranty that has been found to be untrue or incorrect nor shall it adversely affect or waive any obligation of either Party under this Agreement.

Article 6

Disclaimer

6.1. Disclaimer

- (i) The Contractor acknowledges that prior to the execution of this Agreement, the Contractor has, after a complete and careful examination, made an independent evaluation of the Request for Proposal, Scope of the Project, Specifications and Standards of design, construction and maintenance, Site, local conditions, physical qualities of ground, subsoil and geology, traffic volumes, suitability and availability of access routes to the Site and all information provided by the Authority or obtained, procured or gathered otherwise, and has determined to its satisfaction the accuracy or otherwise thereof and the nature and extent of difficulties, risks and hazards as are likely to arise or may be faced by it in the course of performance of its obligations hereunder. Save as provided in Clause 3.1 and Clause 5.2, the Authority makes no representation whatsoever, express, implicit or otherwise, regarding the accuracy, adequacy, correctness, reliability and/or completeness of any assessment, assumptions, statement or information provided by it and the Contractor confirms that it shall have no claim whatsoever against the Authority in this regard.
- (ii) The Contractor acknowledges and hereby accepts to have satisfied itself as to the correctness and sufficiency of the Contract Price.
- (iii) The Contractor acknowledges and hereby accepts the risk of inadequacy, mistake or error in or relating to any of the matters set forth in Clause 6.1 (i) above and hereby acknowledges and agrees that the Authority shall not be liable for the same in any manner whatsoever to the Contractor, or any person claiming through or under any of them, and shall not lead to any adjustment of Contract Price or Scheduled Completion Date.
- (iv) The Parties agree that any mistake or error in or relating to any of the matters set forth in Clause 6.1 (i) above shall not vitiate this Agreement, or render it voidable.
- (v) In the event that either Party becomes aware of any mistake or error relating to any of the matters set forth in Clause 6.1 (i) above, that Party shall immediately notify the other Party, specifying the mistake or error.
- (vi) Except as otherwise provided in this Agreement, all risks relating to the Project shall be borne by the Contractor; and the Authority shall not be liable in any manner for such risks or the consequences thereof.

Part III
Construction and Maintenance

Article 7

Performance Security

7.1. Performance Security

- (i) (A) Within 30 (thirty) days of receipt of Letter of Acceptance, the selected Bidder shall furnish to the Authority an irrevocable and unconditional guarantee from a Bank in the form set forth in Annex-I of Schedule-G (the "Performance Security") for an amount equal to 5% (five percent) of its Bid Price. In case of bids mentioned below, the Selected Bidder, along with the Performance Security, shall also furnish to the Authority an irrevocable and unconditional guarantee from a Bank in the same form given at Annex-I of Schedule-G towards an Additional Performance Security (the "Additional Performance Security") for an amount calculated as under:
- (a) If the Bid Price offered by the Selected Bidder is lower than 10% but upto 20% of the estimated Project Cost, then the Additional Performance Security shall be calculated @20% of the difference in the (i) Estimated Project Cost (as mentioned in RFP)-10% of the Estimated Project Cost and (ii) the Bid Price offered by the selected Bidder.
 - (b) If the Bid Price offered by the Selected Bidder is lower than 20% of the Estimated Project Cost, then the Additional Performance Security shall be calculated @ 30% of the difference in the (i) Estimated Project Cost (as mentioned in RFP)-10% of the Estimated Project Cost and (ii) the Bid Price offered by the Selected Bidder.
 - (c) This Additional Performance Security shall be treated as part of the Performance Security.
- (B) The Performance Security shall be valid until 60 (sixty) days after the Defects Liability Period. The Additional Performance Security shall be valid until 28 (twenty eight) days after Project Completion Date.
- (ii) The Selected Bidder has the option to provide 50% of the Performance Security and 50% of the Additional Performance Security, if any, within 30 (thirty) days of receipt of Letter of Acceptance, in any case before signing of the Contract Agreement and the remaining Performance Security and Additional Performance Security, if any, shall be submitted within 30 days of signing of this agreement.
- (iii) In the event the Selected Bidder fails to provide the remaining Performance Security and Additional Performance Security, if any, as prescribed herein, it may seek extension of time for a further period upto 60 days by paying the Damages upfront along with the request letter seeking the extension. The Damages shall be the sum calculated at the rate of 0.01% (zero point zero one per cent) of the Bid Price offered by the Selected Bidder for each day until the Performance Security and Additional Performance Security, if any, is provided in full as prescribed herein. The damages at full rate as given above shall be applicable even if a part of the Performance Security and the Additional Performance Security is provided.

- (iv) For avoidance of any doubt, in case of failure of submission of Performance Security and Additional Performance Security, if any, within the additional 60 days' time period, the award shall be deemed to be cancelled/ withdrawn and the Bid Security shall be encashed and the proceeds thereof appropriated by the Authority. Thereupon all rights, privileges, claims and entitlements of the Contractor under or arising out of the Award shall be deemed to have been waived by, and to have ceased with the concurrence of the Contractor, and the Award shall be deemed to have been withdrawn by the Authority

7.2. Extension of Performance Security and Additional Performance Security

The Contractor may initially provide the Performance Security for a period of 2 (two) years; provided that it shall procure the extension of the validity of the Performance Security, as necessary, at least 2 (two) months prior to the date of expiry thereof. Upon the Contractor providing an extended Performance Security, the previous Performance Security shall be deemed to be released and the Authority shall return the same to the Contractor within a period of 7 (seven) business days from the date of submission of the extended Performance Security.

7.3. Appropriation of Performance Security

- (i) Upon occurrence of a Contractor's Default, the Authority shall, without prejudice to its other rights and remedies hereunder or in law, be entitled to encash and appropriate the relevant amounts from the Performance Security as Damages for such Contractor's Default.
- (ii) Upon such encashment and appropriation from the Performance Security, the Contractor shall, within 30 (thirty) days thereof, replenish, in case of partial appropriation, to its original level the Performance Security, and in case of appropriation of the entire Performance Security provide a fresh Performance Security, as the case may be, and the Contractor shall, within the time so granted, replenish or furnish fresh Performance Security as aforesaid failing which the Authority shall be entitled to terminate the Agreement in accordance with Article 23. Upon replenishment or furnishing of a fresh Performance Security, as the case may be, as aforesaid, the Contractor shall be entitled to an additional Cure Period of 30 (thirty) days for remedying the Contractor's Default, and in the event of the Contractor not curing its default within such Cure Period, the Authority shall be entitled to encash and appropriate such Performance Security as Damages, and to terminate this Agreement in accordance with Article 23.

7.4. Release of Performance Security

- (i) The Authority shall return the Performance Security to the Contractor within 60 (sixty) days of the expiry of the Maintenance Period or the Defects Liability Period, whichever is later, under this Agreement. Notwithstanding the aforesaid, the Parties agree that the Authority shall not be obliged to release the Performance Security until all Defects identified during the Defects Liability Period have been rectified.
- (ii) The Authority shall return the Additional Performance Security to the Contractor

within 28 (twenty eight) days from the date of issue of Completion Certificate under Article 12 of this Agreement.

- (iii) The Authority shall be liable to pay interest @ 9% (nine per cent) per annum for any delay in the return of Performance Security and Additional Performance Security, if any, beyond the period prescribed above for the period of delay.

7.5. Retention Money

- (i) From every payment for Works due to the Contractor in accordance with the provisions of Clause 19.5, the Authority shall deduct 6% (six per cent) thereof as guarantee money for performance of the obligations of the Contractor during the Construction Period (the "Retention Money") subject to the condition that the maximum amount of Retention Money shall not exceed 5% (five per cent) of the Contract Price.
- (ii) Upon occurrence of a Contractor's Default, the Authority shall, without prejudice to its other rights and remedies hereunder or in law, be entitled to appropriate the relevant amounts from the Retention Money as Damages for such Contractor's Default.
- (iii) Within 15 (fifteen) days of the date of issue of the Completion Certificate, the Authority shall refund the balance of Retention Money remaining with the Authority after adjusting the amounts appropriated under the provisions of Clause 7.5 (ii).
- (iv) The Parties agree that in the event of Termination of this Agreement, the Retention Money specified in this Clause 7.5 shall be treated as if they are Performance Security and shall be reckoned as such for the purposes of Termination Payment under Clause 23.6.

Article 8

Right of Way

8.1. The Site

The site of the Project Highway (the "**Site**") shall comprise the site described in Schedule-A in respect of which the Right of Way shall be provided by the Authority to the Contractor. The Authority shall be responsible for:

- (a) acquiring and providing Right of Way on the Site in accordance with the alignment finalised by the Authority, free from all encroachments and encumbrances, and free access thereto for the execution of this Agreement;
and
- (b) obtaining licences and permits for environment clearance for the Project Highway.

8.2. Procurement of the Site

- (i) The Authority Representative, the Contractor and Authority's Engineer shall, within 10 (ten) days of the date of this Agreement, inspect the Site and prepare a detailed memorandum containing an inventory of the Site including the vacant and unencumbered land, buildings, structures, road works, trees and any other immovable property on or attached to the Site (hereinafter referred to as the "**Handover Memorandum**"). Subject to the provisions of Clause 8.2 (iii), the Handover Memorandum shall have appended thereto an appendix (the "Appendix") specifying in reasonable detail those parts of the Site to which vacant access and Right of Way has not been given to the Contractor along with details of hindrances in the Construction Zone. For sake of clarity the Handover Memorandum shall clearly specify the parts of Site where work can be executed. Signing of the Handover Memorandum, in three counterparts (each of which shall constitute an original), by the authorized representatives of the Authority, Contractor and Authority's Engineer shall be deemed to constitute a valid evidence of giving the Right of Way to the Contractor for discharging its obligations under and in accordance with the provisions of this Agreement and for no other purpose whatsoever.
- (ii) Whenever the Authority is ready to hand over any part or parts of the Site included in the Appendix, it shall inform the Contractor, by notice, of the proposed date and time such of hand over. The Authority Representative and the Contractor shall, on the date so notified, inspect the specified parts of the Site, and prepare a memorandum containing an inventory of the vacant and unencumbered land, buildings, structures, road works, trees and any other immovable property on or attached to the Site so handed over. The signing of the memorandum, in three (3) counterparts (each of which shall constitute an original), by the authorised representatives of the Parties shall be deemed to constitute a valid evidence of giving the relevant Right of Way to the Contractor.

If the contractor fails to join for site inspection or disputes the parts of the site

available for work, the Authority's Engineer shall decide the parts of the site where work can be executed and notify to both the parties within 3 days of the proposed date of inspection. The parties agree that such notification of the Authority's Engineer as mentioned hereinabove shall be final and binding on the parties.

- (iii) The Authority shall provide the Right of Way to the Contractor in respect of all land included in the Appendix by the date specified in Schedule-A for those parts of the Site referred to therein, and in the event of delay for any reason other than Force Majeure or breach of this Agreement by the Contractor, it shall pay to the Contractor, Damages in a sum calculated in accordance with Clause 8.3. The Contractor agrees that it shall not be entitled to claim any other damages on account of any such delay by the Authority.
- (iv) Notwithstanding anything to the contrary contained in this Clause 8.2, the Authority shall specify the parts of the Site, if any, for which Right of Way shall be provided to the Contractor on the dates specified in Schedule-A. Such parts shall also be included in the Appendix prepared in pursuance of Clause 8.2 (i).
- (v) The Authority further acknowledges and agrees that prior to the Appointed Date, it shall have procured issuance of the statutory notification under Applicable Laws for vesting of all the land comprising the Project in the Authority and has taken possession of area for Construction Zone for at least 90% (ninety per cent) of the total length of the Project Highway. The Parties also acknowledge and agree that the conditions specified in this Clause 8.2 (iii) shall not be modified or waived by either Party.
- (vi) For the avoidance of doubt, the Parties expressly agree that the Appendix shall in no event contain sections of the Project Highway the cumulative length of which exceeds 10% (ten percent) of the total length of the Project Highway.
- (vii) Pursuant to signing of Handover Memorandum under clause 8.2 (i), Contractor shall submit to the Authority's Engineer, a monthly land possession report till expiry of 180 (one hundred and eighty) days from Appointed Date, in respect of those parts of the site to which vacant access and right of way was not given to the contractor and included in Appendix to the memorandum signed under clause 8.2 (i), duly specifying the part of the site, if any, for which the right of way is yet to be handed over.

8.3. Damages for delay in handing over the Site

- (i) In the event the Right of Way to any part of the Site is not provided by the Authority on or before the date(s) specified in Clause 8.2 for any reason other than Force Majeure or breach of this Agreement by the Contractor, the Authority shall pay Damages to the Contractor a sum calculated in accordance with the following formula for and in respect of those parts of the Site to which the Right of Way has not been provided:

Amount of Damages in Rs. per day per metre = $0.05 \times C \times 1/L \times 1/N$

Where,

C = the Contract Price;

L = length of the Project Highway in metres; and

N = Completion period in days (Appointed Date to Scheduled Completion Date)

In the event that any Damages are due and payable to the Contractor under the provisions of this Clause 8.3 (i) for delay in providing the Right of Way, the Contractor shall, subject to the provisions of Clause 10.5, be entitled to Time Extension equal to the period for which the Damages have become due and payable under this Clause 8.3 (i), save and except that:

- (a) if any delays involve time overlaps, the overlaps shall not be additive; and
- (b) such Time Extension shall be restricted only to the Works which are affected by the delay in providing the Right of Way.

For the avoidance of doubt, the Parties expressly agree that the Damages specified hereunder and the Time Extension specified in Clause 10.5 shall be restricted only to failure of the Authority to provide the Right of Way for and in respect of the "Construction Zone" which shall comprise the following components:

- Main in carriageway
 - Median (for 4 lane carriageway or more)
 - Paved and earthen shoulders
 - Area for Structures including ROB/RUBs.
 - Safety measures including Roadside Drains and Furniture.
 - A parallel working space for accommodating slopes/retaining structures etc.
- (ii) Notwithstanding anything to the contrary contained in this Agreement, the Contractor expressly agrees that Works on all parts of the Site for which Right of Way of Construction Zone is granted on the Appointed Date, or with respect to the parts of the Site provided in Schedule-A, no later than the date(s) specified therein, as the case may be, shall be completed before the Scheduled Completion Date and shall not qualify for any Time Extension under the provisions of Clause 8.3 (iii).
 - (iii) (a) Notwithstanding anything to the contrary contained in this Agreement, the Authority may at any time withdraw any Works forming part of this Agreement, subject to such Works not exceeding an aggregate value, such value to be determined in accordance with Schedule-H, equal to 10 (ten) percent of the Contract Price.
 - (b) Provided that if any Works cannot be undertaken within the municipal limits of a town or within any area falling in a reserved forest or wildlife sanctuary or the stretches where vacant access and Right of Way could not be handed over, as the case may be, because the requisite clearances or approvals or affected land parcels for commencing construction of Works therein have not been given within 180 (one

hundred and eighty) days of the Appointed date, the affected Works shall be deemed to be withdrawn under the provisions of this Clause 8.3.3. Such Works shall not be computed for the purposes of the aforesaid ceiling of 10% (ten per cent) hereunder.

- (c) Provided further that in case such stretches (as mentioned in Sub-Clause (b) above) can be handed over to the Contractor before the expiry of the original Scheduled Construction Period of the Project Highway, and the Contractor agrees to take up the work, the same may be allowed to be executed by him with corresponding Extension of Time, subject to the condition that the Contractor shall not be entitled to raise any claims on account of prolongation costs in this behalf.
- (iv) In the event of withdrawal of Works under Clause 8.3 (iii) (a), the Contract Price shall be reduced by an amount equal to 90 (ninety) per cent of the value of the Works withdrawn and the Contractor shall not be entitled to any other compensation or Damages for the withdrawal of Works.

Provided that if any Works are withdrawn after commencement of the Construction of such works, the Authority shall pay to the Contractor 110% (one hundred and ten per cent) of the fair value of the work done, as assessed by the Authority' Engineer.

The parties expressly agree that the value of the Works withdrawn shall be determined from the details available in Schedule-H. In the event that it is impossible to determine the value from Schedule-H, then the value shall be determined in accordance with the provisions of Clause 13.2 (iii).

8.4. Site to be free from Encumbrances

Subject to the provisions of Clause 8.2, the Site shall be made available by the Authority to the Contractor pursuant hereto free from all Encumbrances and occupations and without the Contractor being required to make any payment to the Authority because of any costs, compensation, expenses and charges for the acquisition and use of such Site for the duration of the Project Completion Schedule. For the avoidance of doubt, it is agreed that the existing rights of way, easements, privileges, liberties and appurtenances to the Site shall not be deemed to be Encumbrances. It is further agreed that, unless otherwise specified in this Agreement, the Contractor accepts and undertakes to bear any and all risks arising out of the inadequacy or physical condition of the Site.

8.5. Protection of Site from encroachments

On and after signing the memorandum and/or subsequent memorandum referred to in Clause 8.2, and until the issue of the Completion Certificate, the Contractor shall maintain a round-the-clock vigil over the Site and shall ensure and procure that no encroachment takes place thereon. During the Construction Period, the Contractor shall protect the Site from any and all occupations, encroachments or Encumbrances, and shall not place or create nor permit any Sub-contractor or other person claiming through or under the Agreement to place or create any Encumbrance or security threat over all or any part of the Site or the Project Assets, or on any rights of the Contractor

therein or under this Agreement, save and except as otherwise expressly set forth in this Agreement. In the event of any encroachment or occupation on any part of the Site, the Contractor shall report such encroachment or occupation forthwith to the Authority and undertake its removal at its own cost and expenses.

8.6. Special/ temporary Right of Way

The Contractor shall bear all costs and charges for any special or temporary right of way required by it in connection with access to the Site. The Contractor shall obtain at its cost such facilities on or outside the Site as may be required by it for the purposes of the Project Highway and the performance of its obligations under this Agreement.

8.7. Access to the Authority and the Authority's Engineer

- (i) The Right of Way given to the Contractor hereunder shall always be subject to the right of access of the Authority and the Authority's Engineer and their employees and agents for inspection, viewing and exercise of their rights and performance of their obligations under this Agreement.
- (ii) The Contractor shall ensure, subject to all relevant safety procedures, that the Authority has un-restricted access to the Site during any emergency situation, as decided by the Authority's Engineer.

8.8. Geological and archaeological finds

It is expressly agreed that mining, geological or archaeological rights do not form part of this Agreement with the Contractor for the Works, and the Contractor hereby acknowledges that it shall not have any mining rights or interest in the underlying minerals, fossils, antiquities, structures or other remnants or things either of particular geological or archaeological interest and that such rights, interest and property on or under the Site shall vest in and belong to the Authority or the concerned Government Instrumentality. The Contractor shall take all reasonable precautions to prevent its workmen or any other person from removing or damaging such interest or property and shall inform the Authority forthwith of the discovery thereof and comply with such instructions as the concerned Government Instrumentality may reasonably give for the removal of such property. For the avoidance of doubt, it is agreed that any reasonable expenses incurred by the Contractor hereunder shall be reimbursed by the Authority. It is also agreed that the Authority shall procure that the instructions hereunder are issued by the concerned Government Instrumentality within a reasonable period.

Article 9

Utilities and Trees

9.1. Existing utilities and roads

Notwithstanding anything to the contrary contained herein, it shall be the responsibility of the Contractor to ensure that the respective entities owning the existing roads, right of way, level crossings, structures, or utilities on, under or above the Site are enabled by it to keep them in continuous satisfactory use, if necessary, by providing suitable temporary diversions with the authority of the controlling body of that road, right of way or utility.

9.2. Shifting of obstructing utilities

The Contractor shall, in accordance with Applicable Laws and with assistance of the Authority, undertake the work of shifting of any utility (including electric lines, water pipes, gas pipelines and telephone cables) to an appropriate location or alignment, if such utility or obstruction adversely affects the execution of Works or Maintenance of the Project Highway in accordance with this Agreement. The cost of such shifting, as per estimates prepared by the entity owning the utility and approved by the Authority, shall be reimbursed by the Authority to the Contractor. The scope of work of such shifting of Utilities shall be as indicated in Schedule-B. In the event of any delay of such shifting on the part of the contractor, no extension of time for completion of the project and no claims, in any manner, shall be admissible on this account against the Authority.

The work of shifting of Utilities can be taken up by the Contractor any time after signing of the Agreement.

9.3. New utilities

- (i) The Contractor shall allow, subject to the permission from the Authority and such conditions as the Authority may specify, access to, and use of the Site for laying telephone lines, water pipes, electricity lines/ cables or other public utilities. Where such access or use causes any financial loss to the Contractor, it may require the user of the Site to pay compensation or damages as per Applicable Laws. For the avoidance of doubt, it is agreed that use of the Site under this Clause 9.3 shall not in any manner relieve the Contractor of its obligation to construct and maintain the Project Highway in accordance with this Agreement and any damage caused by such use shall be restored forthwith at the cost of the Authority.
- (ii) The Authority may, by notice, require the Contractor to connect any adjoining road to the Project Highway, and the connecting portion thereof falling within the Site shall be constructed by the Contractor at the Authority's cost in accordance with Article 10.
- (iii) The Authority may by notice require the Contractor to connect, through a paved road, any adjoining service station, hotel, motel or any other public facility or amenity to the

Project Highway, whereupon the connecting portion thereof that falls within the Site shall be constructed by the Contractor on payment of the cost. The cost to be paid by the Authority to the Contractor shall be determined by the Authority's Engineer. For the avoidance of doubt, in the event such road is to be constructed for the benefit of any entity, the Authority may require such entity to make an advance deposit with the Contractor or the Authority, as the case may be, of an amount equal to the estimated cost as determined by the Authority's Engineer and such advance shall be adjusted against the cost of construction as determined by the Authority's Engineer hereunder.

- (iv) In the event construction of any Works is affected by a new utility or works undertaken in accordance with this Clause 9.3, the Contractor shall be entitled to a reasonable Time Extension as determined by the Authority's Engineer.

9.4. Felling of trees

The Authority shall assist the Contractor in obtaining the Applicable Permits for felling of trees in non-forest area to be identified by the Authority for this purpose if, and only if, such trees cause a Material Adverse Effect on the construction or maintenance of the Project Highway. The Contractor shall fell these trees as per the Permits obtained. The cost of such felling shall be borne by the Authority and in the event of any delay in felling thereof for reasons beyond the control of the Contractor; it shall be excused for failure to perform any of its obligations hereunder if such failure is a direct consequence of delay in the felling of trees. The Parties hereto agree that the felled trees shall be deemed to be owned by the Authority and shall be disposed in such manner and subject to such conditions as the Authority may in its sole discretion deem appropriate. For the avoidance of doubt, the Parties agree that if any felling of trees hereunder is in a forest area, the Applicable Permit thereof shall be procured by the Authority within the time specified in the Agreement.

9.5. Dismantling of structures

The Contractor shall at its own cost dismantle the structures in the acquired lands including those on patta lands, abadi lands, assigned lands, etc. the compensation for which, was paid by the Authority to the land owners and the lands were handed over to the Contractor. The Contractor shall, at its own cost, dispose off the dismantled material in its sole discretion as deemed appropriate, while complying with all environmental guidelines and regulations and clear the Site for undertaking construction. In the event of any delay in dismantling of structures thereof for reasons beyond the control of the Contractor, the Contractor shall be entitled to Damages in a sum calculated in accordance with the formula specified in Clause 8.3 (i) for the period of delay, and to the Time Extension in accordance with Clause 10.5 for and in respect of the part(s) of the Works affected by such delay; provided that if the delays involve any time overlaps, the overlaps shall not be additive.

9.6. Development Period

The Contractor may commence pre-construction activities like utility shifting, boundary wall construction or any other activity assigned to the Contractor by the

Authority to enable construction of the Project Highway immediately after signing of the Agreement, to the extent that such work is ready for execution. The Parties agree that these works may be taken up and completed to the extent feasible by the Contractor, before declaration of the Appointed Date, but no claim against the Authority for delay shall survive during this period and that the undertaking of these works by the Contractor shall not count towards the Scheduled Construction Period of the project which starts counting only from the Appointed Date. No construction activity of the Project Highway shall be undertaken during the development period.

Article 10

Design and Construction of the Project Highway

10.1. Obligations prior to commencement of Works

- (i) Within 20 (twenty) days of the Appointed Date, the Contractor shall:
 - (a) appoint its representative, duly authorised to deal with the Authority in respect of all matters under or arising out of or relating to this Agreement;
 - (b) appoint a design director (the "**Design Director**") who will head the Contractor's design unit and shall be responsible for surveys, investigations, collection of data, and preparation of preliminary and detailed designs;
 - (c) undertake and perform all such acts, deeds and things as may be necessary or required before commencement of Works under and in accordance with this Agreement, the Applicable Laws and Applicable Permits; and
 - (d) make its own arrangements for quarrying of materials needed for the Project Highway under and in accordance with the Applicable Laws and Applicable Permits.
- (ii) The Authority shall, appoint an engineer (the "**Authority's Engineer**") before the Appointed Date to discharge the functions and duties specified in this Agreement, and shall notify to the Contractor the name, address and the date of appointment of the Authority's Engineer forthwith.
- (iii) Within 30 (thirty) days of the Appointed Date, the Contractor shall submit to the Authority and the Authority's Engineer a programme (the "**Programme**") for the Works, developed using networking techniques, for review and consent of the Engineer, giving the following details:
 - (a) Part I : Contractor's organisation for the Project, the general methods and arrangements for design and construction, environmental management plan, Quality Assurance Plan including design quality plan, traffic management and safety plan covering safety of users and workers during construction (including use of 'ROBOTS' for diversion and control of traffic), Contractor's key personnel and equipment.
 - (b) Part II : Programme for completion of all stages of construction given in Schedule-H and Project Milestones of the Works as specified in Project Completion Schedule set forth in Schedule-J. The Programme shall include:
 - i. the order in which the Contractor intends to carry out the Works, including the anticipated timing of design and stages of Works;
 - ii. the periods for reviews under Clause 10.2;

- iii. the sequence and timing of inspections and tests specified in this Agreement; and
- iv. the particulars for the pre-construction reviews and for any other submissions, approvals and consents specified in the Agreement.

The Contractor shall submit a revised Programme whenever the previous Programme is inconsistent with the actual progress or with the Contractor's obligations.

- (c) Part III : Monthly cash flow forecast.
- (iv) The Contractor shall compute, on the basis of the Drawings prepared in accordance with Clause 10.2 (iv), and provide to the Authority's Engineer, the length, area and numbers, as the case may be, in respect of the various items of work specified in Schedule-H and comprising the Scope of the Project. The Parties expressly agree that these details shall form the basis for estimating the interim payments for the Works in accordance with the provisions of Clause 19.3. For the avoidance of doubt, the sum of payments to be computed in respect of all the items of work shall not exceed the Contract Price, as may be adjusted in accordance with the provisions of this Agreement.
- (v) The Contractor shall appoint a safety consultant (the "Safety Consultant") to carry out a safety audit at the design stage of the Project Highway in accordance with the Applicable Laws and Good Industry Practice. The Safety Consultant shall be appointed after proposing to the Authority a panel of three (3) names of qualified and experienced firms from which the Authority may choose one (1) to be the Safety Consultant. Provided, however, that if the panel is not acceptable to the Authority and the reasons for the same are furnished to the Contractor, the Contractor shall propose to the Authority a revised panel of three (3) names from the firms empanelled as safety consultants by the [Ministry of Road Transport and Highways] for obtaining the consent of the Authority. The Contractor shall also obtain the consent of the Authority for the key personnel of the Safety Consultant who shall have adequate experience and qualifications in safety audit of the highway projects. The Authority shall, within 15 (fifteen) days of receiving a proposal from the Contractor hereunder, convey its decision, with reasons, to the Contractor, and if no such decision is conveyed within the said period, the Contractor may proceed with engaging of the Safety Consultant.
- (vi) The safety audit pursuant to Clause 10.1 (v) shall be carried out by the Safety Consultant in respect of all such design details that have a bearing on safety of Users as well as pedestrians and animals involved in or associated with accidents. The recommendations of the Safety Consultant shall be incorporated in the design of the Project Highway and the Contractor shall forward to the Authority's Engineer a certificate to this effect together with the recommendations of the Safety Consultant. In the event that any works required by the Safety Consultant shall fall beyond the scope of Schedule-B, Schedule-C or Schedule-D, the Contractor shall make a report thereon and seek the instructions of the Authority for Change in Scope. For the avoidance of doubt, the Safety Consultant to be engaged by the Contractor shall be independent of the design and implementation team of the Contractor.

10.2. Design and Drawings

- (i) Design and Drawings shall be developed in conformity with the Specifications and Standards set forth in Schedule-D. In the event, the Contractor requires any relaxation in design standards due to restricted Right of Way in any section, the alternative design criteria for such section shall be provided for review and approval of the Authority's Engineer.
- (ii) The Contractor shall appoint a proof check consultant (the "Proof Consultant") after proposing to the Authority a panel of three (3) names of qualified and experienced firms from whom the Authority may choose one (1) to be the Proof Consultant. Provided, however, that if the panel is not acceptable to the Authority and the reasons for the same are furnished to the Contractor, the Contractor shall propose to the Authority a revised panel of three (3) names from the firms empanelled as proof consultants by the [Ministry of Road Transport and Highways] for obtaining the consent of the Authority. The Contractor shall also obtain the consent of the Authority for two (2) key personnel of the Proof Consultant who shall have adequate experience and qualifications in highways and bridges respectively. The Authority shall, within 15 (fifteen) days of receiving a proposal from the Contractor hereunder, convey its decision, with reasons, to the Contractor, and if no such decision is conveyed within the said period, the Contractor may proceed with engaging of the Proof Consultant.
- (iii) The Proof Consultant shall:
 - (a) evolve a systems approach with the Design Director so as to minimise the time required for final designs and construction drawings; and
 - (b) proof check the detailed calculations, drawings and designs, which have been approved by the Design Director.
- (iv) In respect of the Contractor's obligations with respect to the design and Drawings of the Project Highway as set forth in Schedule-I, the following shall apply:
 - (a) The Contractor shall prepare and submit, with reasonable promptness and in such sequence as is consistent with the Project Completion Schedule, three (3) copies each of the design and Drawings, duly certified by the Proof Consultant, to the Authority's Engineer for its approval. Provided, however, that in respect of Major Bridges and Structures, the Authority's Engineer may require additional drawings for approval in accordance with Good Industry Practice.
 - (b) by submitting the Drawings for review and approval to the Authority's Engineer, the Contractor shall be deemed to have represented that it has determined and verified that the design and engineering, including field construction criteria related thereto, are in conformity with the Scope of the Project, the Specifications and Standards and the Applicable Laws;
 - (c) within 15 (fifteen) days of the receipt of the Drawings, the Authority's Engineer shall review the same and convey its approval/observations to the

Contractor with particular reference to their conformity or otherwise with the Scope of the Project and the Specifications and Standards. Provided, however that in case of a major bridge or structure, the aforesaid period of 15 (fifteen) days may be extended up to 30 (thirty) days;

- (d) if the aforesaid observations of the Authority's Engineer indicate that the Drawings are not in conformity with the Scope of the Project or the Specifications and Standards, such Drawings shall be revised by the Contractor in conformity with the provisions of this Agreement and resubmitted to the Authority's Engineer for review and approval. The Authority's Engineer shall give its observations, if any, within 10 (ten) days of receipt of the revised Drawings. In the event the Contractor fails to revise and resubmit such Drawings to the Authority's Engineer for review/approval as aforesaid, the Authority's Engineer may withhold the payment for the affected works in accordance with the provisions of Clause 19.5 (iv). If the Contractor disputes any decision, direction or determination of the Authority's Engineer hereunder, the Dispute shall be resolved in accordance with the Dispute Resolution Procedure;
- (e) no review/approval and/or observation of the Authority's Engineer and/or its failure to review/approval and/or convey its observations on any Drawings shall relieve the Contractor of its obligations and liabilities under this Agreement in any manner nor shall the Authority's Engineer or the Authority be liable for the same in any manner; and if errors, omissions, ambiguities, inconsistencies, inadequacies or other Defects are found in the Drawings, they and the construction works shall be corrected at the Contractor's cost, notwithstanding any approval under this Article 10;
- (f) the Contractor shall be responsible for delays in submitting the Drawing as set forth in Schedule-I caused by reason of delays in surveys and field investigations, and shall not be entitled to seek any relief in that regard from the Authority; and
- (g) the Contractor warrants that its designers, including any third parties engaged by it, shall have the required experience and capability in accordance with Good Industry Practice and it shall indemnify the Authority against any damage, expense, liability, loss or claim, which the Authority might incur, sustain or be subject to arising from any breach of the Contractor's design responsibility and/or warranty set out in this Clause.
- (h) the Contractor shall ensure that all the designs and drawings shall be approved from the Authority's Engineer within 90 days (ninety) from the Appointed Date.
- (v) Any cost or delay in construction arising from review/approval by the Authority's Engineer shall be borne by the Contractor.
- (vi) Works shall be executed in accordance with the Drawings provided by the Contractor

in accordance with the provisions of this Clause 10.2 and the approval of the Authority's Engineer thereon as communicated pursuant to the provisions of sub-Clause (c) & (d) of Clause 10.2 (iv). Such Drawings shall not be amended or altered without prior written notice to the Authority's Engineer. If a Party becomes aware of an error or defect of a technical nature in the design or Drawings, that Party shall promptly give notice to the other Party of such error or defect.

- (vii) Within 90 (ninety) days of the Project Completion Date, the Contractor shall furnish to the Authority and the Authority's Engineer a complete set of as-built Drawings, in 2 (two) hard copies and in micro film form or in such other medium as may be acceptable to the Authority, reflecting the Project Highway as actually designed, engineered and constructed, including an as-built survey illustrating the layout of the Project Highway and setback lines, if any, of the buildings and structures forming part of Project Facilities.

10.3. Construction of the Project Highway

- (i) The Contractor shall construct the Project Highway as specified in Schedule- B and Schedule-C, and in conformity with the Specifications and Standards set forth in Schedule-D. The Contractor shall be responsible for the correct positioning of all parts of the Works, and shall rectify any error in the positions, levels, dimensions or alignment of the Works. **The 730th (Seven Hundred Thirty days)** from the Appointed Date shall be the scheduled completion date (the "Scheduled Completion Date") and the Contractor agrees and undertakes that the construction shall be completed on or before the Scheduled Completion Date, including any extension thereof.
- (ii) The Contractor shall construct the Project Highway in accordance with the Project Completion Schedule set forth in Schedule-J. In the event that the Contractor fails to achieve any Project Milestone or the Scheduled Completion Date within a period of 30 (thirty) days from the date set forth in Schedule-J, unless such failure has occurred due to Force Majeure or for reasons solely attributable to the Authority, it shall pay Damages to the Authority of a sum calculated at the rate of 0.05% (zero point zero five percent) of the Contract Price for delay of each day reckoned from the date specified in Schedule -J and until such Project Milestone is achieved or the Project Highway is completed; provided that if the period for any or all Project Milestones or the Scheduled Completion Date is extended in accordance with the provisions of this Agreement, the dates set forth in Schedule-J shall be deemed to be modified accordingly and the provisions of this Agreement shall apply as if Schedule-J has been amended as above; provided further that in the event the Project Highway is completed within or before the Scheduled Completion Date including any Time Extension, applicable for that work or section, the Damages paid under this Clause 10.3 (ii) shall be refunded by the Authority to the Contractor, but without any interest thereon.

The Parties agree that for determining achievement or delays in completion of the Project Milestones or the Project on the due date, the works affected due to delay in providing the site for which time extension has been granted beyond the Scheduled Completion Date will be excluded. For example on the due date to achieve the Project

Milestone-I (i.e., Stage Payments of 10% (ten percent) of Contract Price on 180th (one hundred and eighty) day from the Appointed Date), if 5% (five percent) of the project length corresponding to the Project Milestone-I is not handed over or lately handed over resulting in the extension of completion of this 5% (five percent) length beyond Scheduled Completion Date, Stage Payment of $10\% \times 0.95 = 9.5\%$ only is to be achieved by 180th (one hundred and eighty) day.

For the avoidance of doubt, it is agreed that recovery of Damages under this Clause 10.3 (ii) shall be without prejudice to the rights of the Authority under this Agreement including the right of Termination thereof. The Parties further agree that Time Extension hereunder shall only be reckoned for and in respect of the affected Works as specified in Clause 10.5 (ii).

- (iii) The Authority shall notify the Contractor of its decision to impose Damages in pursuance with the provisions of this Clause 10.3. Provided that no deduction on account of Damages shall be effected by the Authority without notifying the Contractor of its decision to impose the Damages, and taking into consideration the representation, if any, made by the Contractor within 20 (twenty) days of such notice. The Parties expressly agree that the total amount of Damages under Clause 10.3 (ii) shall not exceed 10% (ten percent) of the Contract Price. If the damages exceed 10% (ten percent) of the Contract Price, the Contractor shall be deemed to be in default of this agreement having no cure and the Authority shall be entitled to terminate this Agreement by issuing a Termination Notice in accordance with the provisions of Clause 23.1 (ii).
- (iv) In the event that the Contractor fails to achieve the Project Completion within a period of 90 (ninety) days from the Schedule Completion Date set forth in Schedule-J, unless such failure has occurred due to Force Majeure or for reasons solely attributable to the Authority, the contractor shall be deemed to be ineligible for bidding any future projects of the Authority, both as the sole party or as one of the parties of Joint Venture/ Consortium during the period from Scheduled Completion Date to issuance of Completion Certificate. This restriction is applicable if the contract value of the delayed project is not less than Rs. 300 Crore.

10.4. Maintenance during Construction Period

- (i) During the Construction Period, the Contractor shall maintain, at its cost, the existing lane(s) of the Project Highway so that the traffic worthiness and safety thereof are at no time materially inferior as compared to their condition on Appointed Date, and shall undertake the necessary repair and maintenance works for this purpose; provided that the Contractor may, at its cost, interrupt and divert the flow of traffic if such interruption and diversion is necessary for the efficient progress of Works and conforms to Good Industry Practice; provided further that such interruption and diversion shall be undertaken by the Contractor only with the prior written approval of the Authority's Engineer which approval shall not be unreasonably withheld. For the avoidance of doubt, it is agreed that the Contractor shall at all times be responsible for ensuring safe operation of the Project Highway. It is further agreed that in the event the Project includes construction of a bypass or tunnel and realignment of the existing

carriageway, the Contractor shall maintain the existing highway in such sections until the new Works are open to traffic.

- (ii) Notwithstanding anything to the contrary contained in this Agreement, in the event of default by the Contractor in discharging the obligations specified in Clause 10.4 (i) above, the Authority shall get these maintenance works completed in the manner recommended by the Authority's Engineer to avoid public inconvenience at the risk and cost of the Contractor in order to keep the road in traffic worthy condition.

10.5. Extension of time for completion

- (i) Without prejudice to any other provision of this Agreement for and in respect of extension of time, the Contractor shall be entitled to extension of time in the Project Completion Schedule (the "**Time Extension**") to the extent that completion of any Project Milestone is or will be delayed by any of the following, namely:
 - (a) delay in providing the Right of Way of Construction Zone, environmental clearances or approval of railway authorities, specified in Clause 3.1 (iv);
 - (b) Change of Scope (unless an adjustment to the Scheduled Completion Date has been agreed under Article 13);
 - (c) occurrence of a Force Majeure Event;
 - (d) any delay, impediment or prevention caused by or attributable to the Authority, the Authority's personnel or the Authority's other contractors on the Site; and
 - (e) any other cause or delay which entitles the Contractor to Time Extension in accordance with the provisions of this Agreement.
- (ii) The Contractor shall, no later than 15 (fifteen) business days from the occurrence of an event or circumstance specified in Clause 10.5 (i), inform the Authority's Engineer by notice in writing, with a copy to the Authority, stating in reasonable detail with supporting particulars, the event or circumstances giving rise to the claim for Time Extension in accordance with the provisions of this Agreement. Provided that the period of 15 (fifteen) business days shall be calculated from the date on which the Contractor became aware, or should have become aware, of the occurrence of such an event or circumstance.

Provided further that notwithstanding anything to the contrary contained in this Agreement, Time Extension shall be due and applicable only for the Works which are affected by the aforesaid events or circumstances and shall not in any manner affect the Project Completion Schedule for and in respect of the Works which are not affected hereunder.

- (iii) On the failure of the Contractor to issue to the Authority's Engineer a notice in accordance with the provisions of Clause 10.5 (ii) within the time specified therein, the Contractor shall not be entitled to any Time Extension and shall forfeit its right for any

such claims in future. For the avoidance of doubt, in the event of failure of the Contractor to issue notice as specified in this clause 10.5 (iii), the Authority shall be discharged from all liability in connection with the claim.

- (iv) The Authority's Engineer shall, on receipt of the claim in accordance with the provisions of Clause 10.5 (ii), examine the claim expeditiously within the time frame specified herein. In the event the Authority's Engineer requires any clarifications to examine the claim, the Authority's Engineer shall seek the same within 15 (fifteen) days from the date of receiving the claim. The Contractor shall, on receipt of the communication of the Authority's Engineer requesting for clarification, furnish the same to the Authority's Engineer within 10 (ten) days thereof. The Authority's Engineer shall, within a period of 30 (thirty) days from the date of receipt of such clarifications, forward in writing to the Contractor its determination of Time Extension.

Provided that when determining each extension of time under this Clause 10.5, the Authority's Engineer shall review previous determinations and may increase, but shall not decrease, the total Time Extension.

- (v) If the event or circumstance giving rise to the notice has a continuing effect:
- (a) a fully detailed claim shall be considered as interim;
 - (b) the Contractor shall, no later than 10 (ten) days after the close of each month, send further interim claims specifying the accumulated delay, the extension of time claimed, and such further particulars as the Authority's Engineer may reasonably require; and
 - (c) the Contractor shall send a final claim within 30 (thirty) days after the effect of the event or the circumstance ceases.

Upon receipt of the claim hereunder, the Authority's Engineer shall examine the same in accordance with the provisions of Clause 10.5 (iv) within a period of 30 (thirty) days of the receipt thereof

10.6. Incomplete Works

In the event the Contractor fails to complete the Works in accordance with the Project Completion Schedule, including any Time Extension granted under this Agreement, the Contractor shall endeavour to complete the balance work expeditiously and shall pay Damages to the Authority in accordance with the provisions of Clause 10.3 (ii) for delay of each day until the Works are completed in accordance with the provisions of this Agreement. Recovery of Damages under this Clause shall be without prejudice to the rights of the Authority under this Agreement including the right to termination under Clause 23.1.

10.7. Maintenance Manual

No later than 60 (sixty) days prior to the Project Completion Date, the Contractor shall, in consultation with the Authority's Engineer, evolve a maintenance manual (the

"Maintenance Manual") for the regular and preventive maintenance of the Project Highway in conformity with the Specifications and Standards, safety requirements and Good Industry Practice, and shall provide 5 (five) copies thereof to the Authority's Engineer. The Authority's Engineer shall review the Maintenance Manual within 15 (fifteen) days of its receipt and communicate its comments to the Contractor for necessary modifications, if any.

10.8. As-Built Records

The Contractor shall prepare, and keep up-to-date, a complete set of as built records of the execution of the Works, showing the exact as built locations, sizes and details on the Works as executed with cross references to all relevant specifications and data sheets. These records shall be kept on the Site and shall be used exclusively for the purpose of this Sub-Clause 10.8. The Contractor shall provide 2 (two) copies of as built records to the Authority prior to the commencement of the Tests on Completion.

10.9. Contractor's Use of Authority's Documents

Intellectual property in the Authority's requirements and Specifications and Standards and all other documents and materials issued by the Authority or the Authority's Representative to the Contractor shall (as between the parties) remain the property of the Authority. The Contractor may, at its cost, copy, use and communicate any such documents for the purposes of the Contract. They shall not, without the consent of the Authority, be used, copied or communicated to a third party by the Contractor, except as necessary for the purposes of the Works under the Agreement.

Article 11

Quality Assurance, Monitoring and Supervision

11.1. Quality of Materials and workmanship

The Contractor shall ensure that the Construction, Materials and workmanship are in accordance with the requirements specified in this Agreement, Specifications and Standards and Good Industry Practice.

11.2. Quality control system

- (i) The Contractor shall establish a quality control mechanism to ensure compliance with the provisions of this Agreement (the "**Quality Assurance Plan**" or "**QAP**").
- (ii) The Contractor shall, within 30 (thirty) days of the Appointed Date, submit to the Authority's Engineer its Quality Assurance Plan which shall include the following:
 - (a) organization, duties and responsibilities, procedures, inspections and documentation;
 - (b) quality control mechanism including sampling and testing of Materials, test frequencies, standards, acceptance criteria, testing facilities, reporting, recording and interpretation of test results, approvals, check list for site activities, and proforma for testing and calibration in accordance with the Specifications for Road and Bridge Works issued by MORTH, relevant IRC specifications and Good Industry Practice; and
 - (c) internal quality audit system.

The Authority's Engineer shall convey its approval to the Contractor within a period of 21 (twenty-one) days of receipt of the QAP stating the modifications, if any, required, and the Contractor shall incorporate those in the QAP to the extent required for conforming with the provisions of this Clause 11.2.

- (iii) The Contractor shall procure all documents, apparatus and instruments, fuel, consumables, water, electricity, labour, Materials, samples, and qualified personnel as are necessary for examining and testing the Project Assets and workmanship in accordance with the Quality Assurance Plan.
- (iv) The cost of testing of Construction, Materials and workmanship under this Article 11 shall be borne by the Contractor.

11.3. Methodology

The Contractor shall, at least 15 (fifteen) days prior to the commencement of the construction, submit to the Authority's Engineer for review and consent the methodology proposed to be adopted for executing the Works, giving details of

equipment to be deployed, traffic management and measures for ensuring safety. The Authority's Engineer shall complete the review and convey its consent to the Contractor within a period of 10 (ten) days from the date of receipt of the proposed methodology from the Contractor.

11.4. Inspection and technical audit by the Authority

The Authority or any representative authorised by the Authority in this behalf may inspect and review the progress and quality of the construction of Project Highway and issue appropriate directions to the Authority's Engineer and the Contractor for taking remedial action in the event the Works are not in accordance with the provisions of this Agreement.

11.5. External technical audit

- (i) At any time during construction, the Authority may appoint an external technical auditor to conduct an audit of the quality of the Works. The Auditor in the presence of the representatives of the Contractor and the Authority's Engineer shall carry out the tests and/ or collect samples for testing in the laboratory. The timing, the testing equipment and the sample size of this audit shall be as decided by the Authority. The findings of the audit, to the extent accepted by the Authority, shall be notified to the Contractor and the Authority's Engineer for taking remedial action in accordance with this Agreement.
- (ii) After completion of the remedial measures by the Contractor, the Auditor shall undertake a closure audit and this process will continue till the remedial measures have brought the works into compliance with the Specifications and Standards. The Contractor shall provide all assistance as may be required by the auditor in the conduct of its audit hereunder. Notwithstanding anything contained in this Clause 11.5, the external technical audit shall not affect any obligations of the Contractor or the Authority's Engineer under this Agreement.

11.6. Inspection of construction records

The Authority shall have the right to inspect the records of the Contractor relating to the Works.

11.7. Monthly progress reports

During the Construction Period, the Contractor shall, no later than 10 (ten) days after the close of each month, furnish to the Authority and the Authority's Engineer a monthly report on progress of the Works and shall promptly give such other relevant information as may be required by the Authority's Engineer.

The Contractor agrees that reporting under this Clause 11.7 shall continue until the date of the completion of the Works. Each report shall include:

- (a) an executive summary;

- (b) charts showing the status of Contractor's documents, construction and manufacturing and environmental works;
- (c) details of work subcontracted and the performance of Sub-contractors;
- (d) for the construction of each main part of the Works, the extent of progress (both quantity and percentage of the whole), the actual or expected dates of commencement, anticipated completion date of the activity, Contractor's inspections and tests;
- (e) records of manpower and Contractor's equipment on the Site;
- (f) copies for that month of quality assurance documents, test results and certificates;
- (g) safety statistics, accident data collection including details of any hazardous incidents and activities relating to environmental aspects and public relations;
- (h) comparisons of actual and planned progress, with details of any aspects which may jeopardise the completion in accordance with the Agreement, and the measures being (or to be) adopted to overcome such aspects;
- (i) details of any unresolved disputes or claims, in relation to the Project;
- (j) details of any revision to the cash flow estimate, together with a copy of the revised cash flow estimate;
- (k) status of various Applicable Permits and compliance of conditions therein;
- (l) details of various royalty payment and insurances required to be taken by the Contractor; and
- (m) such other reports as may be required by the Authority for enabling the Authority to comply with its obligations under the other Project contracts.
- (n) details of defects by the Authority;
- (o) change in emission of any sewage or effluent of any nature whatsoever, whether qualitatively or quantitatively;
- (p) any Material Adverse Effect;
- (q) declaration towards compliance with Applicable Laws including but not limited to environmental and labour legislations;
- (r) declaration specifying compliance with all Manuals provided to the Contractor; and
- (s) any change in the flow of traffic in the existing Project Highway.

11.8. Inspection

- (i) The Authority's Engineer and its authorised representative shall at all reasonable times:
 - (a) have full access to all parts of the Site and to all places from which natural Materials are being obtained for use in the Works; and
 - (b) during production, manufacture and construction at the Site and at the place of production, be entitled to examine, inspect, measure and test the Materials and workmanship, and to check the progress of manufacture of Materials.
- (ii) The Contractor shall give the Authority's Engineer and its authorised agents access, facilities and safety equipment for carrying out their obligations under this Agreement.
- (iii) The Authority's Engineer shall submit a monthly inspection report (the "**Inspection Report**") to the Authority and the Contractor bringing out the results of inspections and the remedial action taken by the Contractor in respect of Defects or deficiencies. For the avoidance of doubt, such inspection or submission of Inspection Report by the Authority's Engineer shall not relieve or absolve the Contractor of its obligations and liabilities under this Agreement in any manner whatsoever.

11.9. Samples

The Contractor shall submit the following samples of Materials and relevant information to the Authority's Engineer for pre-construction review:

- (a) manufacturer's test reports and standard samples of manufactured Materials; and
- (b) samples of such other Materials as the Authority's Engineer may require.

11.10. Tests

- (i) For determining that the Works conform to the Specifications and Standards, the Authority's Engineer shall require the Contractor to carry out or cause to be carried out tests, at such time and frequency and in such manner as specified in this Agreement, and in accordance with Good Industry Practice for quality assurance. The test checks by the Authority's Engineer shall comprise at least 50% (fifty percent) of the quantity or number of tests prescribed for each category or type of test for quality control by the Contractor.
- (ii) In the event that results of any tests conducted under this Clause 11.10 establish any Defects or deficiencies in the Works, the Contractor shall carry out remedial measures and furnish a report to the Authority's Engineer in this behalf. The Authority's Engineer shall require the Contractor to carry out or cause to be carried out tests to determine that such remedial measures have brought the Works into compliance with the Specifications and Standards, and the procedure shall be repeated until such Works conform to the Specifications and Standards. For the avoidance of doubt, the cost of such tests and remedial measures in pursuance thereof shall be solely borne by the Contractor.

11.11. Examination of work before covering up

In respect of the work which the Authority's Engineer is entitled to examine, inspect, measure and/or test before it is covered up or put out of view or any part of the work is placed thereon, the Contractor shall give notice to the Authority's Engineer whenever any such work is ready and before it is covered up. The Authority's Engineer shall then either carry out the examination, inspection or testing without unreasonable delay, or promptly give notice to the Contractor that the Authority's Engineer does not require to do so. Provided, however, that if any work is of a continuous nature where it is not possible or prudent to keep it uncovered or incomplete, the Contractor shall notify the schedule of carrying out such work to give sufficient opportunity, not being less than 3 (three) business days' notice, to the Authority's Engineer to conduct its inspection, measurement or test while the work is continuing. Provided further that in the event the Contractor receives no response from the Authority's Engineer within a period of 3 (three) business days from the date on which the Contractor's notice hereunder is delivered to the Authority's Engineer, the Contractor shall be entitled to assume that the Authority's Engineer would not undertake the said inspection.

11.12. Rejection

If, as a result of an examination, inspection, measurement or testing, any Plant, Materials, design or workmanship is found to be defective or otherwise not in accordance with the provisions of this Agreement, the Authority's Engineer shall reject the Plant, Materials, design or workmanship by giving notice to the Contractor, with reasons. The Contractor shall then promptly make good the Defect and ensure that the rejected item complies with the requirements of this Agreement.

If the Authority's Engineer requires the Plant, Materials, design or workmanship to be retested, the tests shall be repeated under the same terms and conditions, as applicable in each case. If the rejection and retesting cause the Authority to incur any additional costs, such cost shall be recoverable by the Authority from the Contractor; and may be deducted by the Authority from any monies due to be paid to the Contractor.

11.13. Remedial work

- (i) Notwithstanding any previous test or certification, the Authority's Engineer may instruct the Contractor to:
 - (a) remove from the Site and replace any Plant or Materials which are not in accordance with the provisions of this Agreement;
 - (b) remove and re-execute any work which is not in accordance with the provisions of this Agreement and the Specification and Standards; and
 - (c) execute any work which is urgently required for the safety of the Project Highway, whether because of an accident, unforeseeable event or otherwise; provided that in case of any work required on account of a Force Majeure Event, the provisions of Clause 21.6 shall apply.

- (ii) If the Contractor fails to comply with the instructions issued by the Authority's Engineer under Clause 11.13 (i), within the time specified in the Authority's
- (iii) Engineer's notice or as mutually agreed, the Authority's Engineer may advise the Authority to have the work executed by another agency. The cost so incurred by the Authority for undertaking such work shall, without prejudice to the rights of the Authority to recover Damages in accordance with the provisions of this Agreement, be recoverable from the Contractor and may be deducted by the Authority from any monies due to be paid to the Contractor.

11.14. Delays during construction

Without prejudice to the provisions of Clause 10.3 (ii), in the event the Contractor does not achieve any of the Project Milestones or the Authority's Engineer shall have reasonably determined that the rate of progress of Works is such that Completion of the Project Highway is not likely to be achieved by the end of the Scheduled Completion Date, it shall notify the same to the Contractor, and the Contractor shall, within 15 (fifteen) days of such notice, by a communication inform the Authority's Engineer in reasonable detail about the steps it proposes to take to expedite progress and the period within which it shall achieve the Project Completion Date.

11.15. Quality control records and Documents

The Contractor shall hand over a copy of all its quality control records and documents to the Authority's Engineer before the Completion Certificate is issued pursuant to Clause 12.2. The Contractor shall submit Road Signage Plans to the Authority Engineer for approval at least 6 (six) months prior to expected completion of Project Highway.

11.16. Video recording

During the Construction Period, the Contractor shall provide to the Authority for every calendar quarter, a video recording, which will be compiled into a 3 (three)-hour compact disc or digital video disc, as the case may be, covering the status and progress of Works in that quarter. The video recording shall be provided to the Authority no later than 15 (fifteen) days after the close of each quarter after the Appointed Date.

11.17. Suspension of unsafe Construction Works

- (i) Upon recommendation of the Authority's Engineer to this effect, the Authority may by notice require the Contractor to suspend forthwith the whole or any part of the Works if, in the reasonable opinion of the Authority's Engineer, such work threatens the safety of the Users and pedestrians.
- (ii) The Contractor shall, pursuant to the notice under Clause 11.17 (i), suspend the Works or any part thereof for such time and in such manner as may be specified by the Authority and thereupon carry out remedial measures to secure the safety of suspended works, the Users and pedestrians. The Contractor may by notice require the Authority's Engineer to inspect such remedial measures forthwith and make a report to

the Authority recommending whether or not the suspension hereunder may be revoked. Upon receiving the recommendations of the Authority's Engineer, the Authority shall either revoke such suspension or instruct the Contractor to carry out such other and further remedial measures as may be necessary in the reasonable opinion of the Authority, and the procedure set forth in this Clause 11.17 shall be repeated until the suspension hereunder is revoked.

- (iii) Subject to the provisions of Clause 21.6, all reasonable costs incurred for maintaining and protecting the Works or part thereof during the period of suspension (the "**Preservation Costs**"), shall be borne by the Contractor; provided that if the suspension has occurred as a result of any breach of this Agreement by the Authority, the Preservation Costs shall be borne by the Authority.
- (iv) If suspension of Works is for reasons not attributable to the Contractor, the Authority's Engineer shall determine any Time Extension to which the Contractor is reasonably entitled.

11.18. Staff and Labour

- (i) Engagement of Staff and Labour
 - (a) The Contractor shall make its own arrangements for the engagement of all personnel and labour, local or otherwise, and for their payment, housing, feeding and transport.
 - (b) The Contractor has verified/ shall verify the identity and address of all its employees and officials related to the Works by collecting necessary documentary proof.
 - (c) The Contractor shall conduct pre-employment police verification of the employees and other staffs and shall furnish the police verification report of all such staff/ employees, if requested by the Employer who shall be performing the Works or any part thereof;
 - (d) The Contractor hereby confirms that the Contractor shall not engage any person with a criminal record / conviction and shall bar any such person from participating directly or indirectly in performing the Works.
 - (e) The employees and personnel of the Contractor shall work under the supervision, control and direction of the Contractor and the Contractor shall be solely responsible for all negotiations with our employees and personnel relating to their salaries and benefits, and shall be responsible for assessments and monitoring of performance and for all disciplinary matters. All employees / personnel, executives engaged by the Contractor shall be in sole employment of the Contractor and the Contractor shall be solely responsible for their salaries, wages, statutory payments, etc and under no circumstances the personnel shall be deemed to be the employees of the Employer. Under no circumstances the Authority shall be liable for any payment or claim or

compensation of any nature to the employees and personnel of the Contractor.

(ii) Returns of Labour

- (a) The Contractor shall deliver to the Authority a detailed return in such form and at such intervals as the Authority may prescribe, showing the details including names, payment details and terms of appointment of the several classes of labour employed by the Contractor from time to time for the Works. The Contractor shall, in its returns certify that all dues of the workers or labour have been fully paid.
- (b) The Authority is entitled to witness labour payments made or to be made by the Contractor. If the Contractor defaults in its obligations for making any payments under the labour laws, the Employer may make the relevant payments. Any sum equal to any amount paid by the Employer under this Sub-Sub-Clause 9.2 shall be immediately due as a debt from the Contractor to the Employer and until payment/ set off shall carry interest at 18% per annum. For this purpose it is agreed between the parties that debt due aforesaid shall be set off immediately out the running account bills of the Contractor under this Agreement.

(iii) Persons in the Service of Others

The Contractor shall not recruit, or attempt to recruit from amongst persons in the service of the Authority.

(iv) Labour Laws

- (a) The Contractor shall obtain all relevant labour registrations and comply with all relevant labour laws applying to its employees, and shall duly pay them and afford to them all their legal rights.
- (b) The Contractor shall make all deductions of tax at source and all contributions to the Payment of Gratuity, Provident Fund (including Employees' contribution) and Employees' State Insurance Scheme as may be required by Applicable Laws and deposit the aforesaid contributed amount with the appropriate authority/(s).
- (c) The Contractor shall require all personnel engaged in the Works to obey all Applicable Laws and regulations. The Contractor shall permit Authority to witness labour payments for the Contractors direct labour, or the Subcontractors labour. The Contractor shall ensure that all its Subcontractors strictly comply with all labour laws.
- (d) Documentary evidence confirming compliance with Sub-Clause 12.4, as may be required from time to time, shall be provided to the Employer's Representative.

(e) The Employer shall not be liable for any delay/default of the Contractor in compliance of the labour laws.

(v) Facilities for Staff and Labour

The Contractor shall provide and maintain all necessary accommodation and welfare facilities for personnel engaged for the Works. The Contractor shall not permit any personnel engaged for the Works to maintain any temporary or permanent living quarters within the structures forming part of the Works.

(vi) Health And Safety

All necessary precautions shall be taken by the Contractor to ensure the health and safety of staff and labour engaged for the Works. The Contractor shall, in collaboration with and to the requirements of the local health authorities, ensure that para-medical staff, first aid facilities, ambulance service are available on the Site at all times, and that suitable arrangements are made for all necessary welfare and hygiene requirements and for the prevention of epidemics. The Contractor shall appoint a safety officer to be responsible for the safety of personnel on the Site. This safety officer shall be qualified for his work and shall have the authority to issue instructions concerning safety and take protective measures to prevent accidents. The Contractor shall maintain records and make reports concerning health, safety and welfare of personnel, and damage to property, in such manner as the Authority may reasonably require.

(vii) Contractor's Personnel

The Contractor shall employ only personnel who are appropriately qualified, skilled and experienced in their respective trades or occupations. The Authority may require the Contractor to remove any personnel engaged for the Works, who in the opinion of the Authority:

- (a) has engaged in any misconduct;
- (b) is incompetent or negligent in the performance of his duties;
- (c) fails to conform with any provisions of the Contract;
- (d) engages in any conduct which is prejudicial to safety, health, or the protection of the environment; or
- (e) makes errors in the discharge of his functions.

If appropriate and required by the Employer, the Contractor shall then appoint (or cause to be appointed) a suitable replacement person.

(viii) Disorderly Conduct

The Contractor shall at all times take all reasonable precautions to prevent any unlawful, riotous or disorderly conduct by or amongst its personnel, and to preserve

peace and protection of people and property in the neighbourhood of the Works.

Article 12

Completion Certificate

12.1. Tests on Completion

- (i) At least 30 (thirty) days prior to the likely completion of the Project Highway, or a Section thereof, the Contractor shall notify the Authority's Engineer of its intent to subject the Project Highway or a Section thereof, to Tests. The date and time of each of the Tests shall be determined by the Authority's Engineer in consultation with the Contractor, and notified to the Authority who may designate its representative to witness the Tests. The Contractor shall either conduct the Tests as directed by the Authority's Engineer or provide such assistance as the Authority's Engineer may reasonably require for conducting the Tests. In the event of the Contractor and the Authority's Engineer failing to mutually agree on the dates for conducting the Tests, the Contractor shall fix the dates by giving not less than 10 (ten) days' notice to the Authority's Engineer.
- (ii) All Tests shall be conducted in accordance with Schedule-K. The Authority's Engineer shall either conduct or observe, monitor and review the Tests conducted by the Contractor, as the case may be, and review the results of the Tests to determine compliance of the Project Highway or a Section thereof, with Specifications and Standards and if it is reasonably anticipated or determined by the Authority's Engineer during the course of any Test that the performance of the Project Highway or Section or any part thereof, does not meet the Specifications and Standards, it shall have the right to suspend or delay such Test and require the Contractor to remedy and rectify the Defect or deficiencies. Upon completion of each Test, the Authority's Engineer shall provide to the Contractor and the Authority copies of all Test data including detailed Test results. For the avoidance of doubt, it is expressly agreed that the Authority's Engineer may require the Contractor to carry out or cause to be carried out additional Tests, in accordance with Good Industry Practice, for determining the compliance of the Project Highway or Section thereof with the Specifications and Standards.

12.2. Completion Certificate

- (i) Upon completion of all Works forming part of the Project Highway, and the Authority's Engineer determining the Tests to be successful and after the receipt of notarized true copies of the certificate(s) of insurance, copies of insurance policies and premium payment receipts in respect of the insurance defined in Article 20 and Schedule P of this Agreement, it shall, at the request of the Contractor forthwith issue to the Contractor and the Authority a certificate substantially in the form set forth in Schedule-L (the "Completion Certificate").
- (ii) Upon receiving the Completion Certificate, the Contractor shall remove its equipment, materials, debris and temporary works from the Site within a period of 30 (thirty) days thereof, failing which the Authority may remove or cause to be removed, such equipment, materials, debris and temporary works and recover from the Contractor an amount equal to 120% (one hundred and twenty per cent) of the actual cost of removal

incurred by the Authority.

- (iii) Without prejudice to the obligations of the Contractor specified in Articles 14 and 17, the property and ownership of all the completed Works forming part of the Project Highway shall vest in the Authority.

12.3. Rescheduling of Tests

If the Authority's Engineer certifies to the Authority and the Contractor that it is unable to issue the Completion Certificate, as the case may be, because of events or circumstances on account of which the Tests could not be held or had to be suspended, the Contractor shall be entitled to re-schedule the Tests and hold the same as soon as reasonably practicable.

Article 13

Change of Scope

13.1. Change of Scope

- (i) The Authority may, notwithstanding anything to the contrary contained in this Agreement, require the Contractor to make modifications/ alterations to the Works ("**Change of Scope**") within a period of six months counted from the Appointed Date. Upon the Authority making its intention known to the Contractor for the specific Change of Scope, be it positive or negative, the Contractor shall submit his proposal for the said Change of Scope involving additional cost or reduction in cost. Any such Change of Scope shall be made and valued in accordance with the provisions of this Article 13.
- (ii) Provided that any such Change of Scope, excluding major structures (e.g. Major Bridge/ ROB/ RUB/ Flyover/ elevated road of more than 50 m length) may be required and agreed to be executed between the parties beyond the period of six months of the Appointed Date but before expiry of 50% of the original Scheduled Construction Period of the Project Highway, subject to the condition that it shall not entail any claims (e.g. Extension of Time/ Prolongation related claims), against the Authority.
- (iii) The Change of Scope shall mean the following:
 - (a) change in specifications of any item of Works;
 - (b) omission of any work from the Scope of the Project except under Clause 8.3(iii); provided that, subject to Clause 13.5, the Authority shall not omit any Work under this Clause in order to get it executed by any other authority; and/ or
 - (c) any additional Work, Plant, Materials or services which are not included in the Scope of the Project, including any associated Tests on completion of construction.

13.2. Procedure for Change of Scope

- (i) In the event of the Authority determining that a Change of Scope is necessary, it may direct the Authority's Engineer to issue to the Contractor a notice specifying in reasonable detail the Works and services contemplated there under (the "**Change of Scope Notice**"). The Contractor shall submit a detailed proposal as per Clause 13.2 (iii) within 15 days from the receipt of Change of Scope Notice.
- (ii) If the Contractor determines, not later than 90 days from the Appointed Date, that a Change of Scope to the Works is required, it shall prepare a proposal with relevant details as per Clause 13.2 (iii) at its own cost and shall submit to the Authority to consider such Change of Scope (the "**Change of Scope Request**").

- (iii) Upon receipt of a Change of Scope Notice, the Contractor shall, with due diligence, provide to the Authority and the Authority's Engineer such information as is necessary, together with detailed proposal in support of:
- (a) the impact, if any, which the Change of Scope is likely to have on the Project Completion Schedule if the works or services are required to be carried out during the Construction Period; and
 - (b) the options for implementing the proposed Change of Scope and the effect, if any, each such option would have on the costs and time thereof, including the following details:
 - i. break-up of the quantities, unit rates and cost for different items of work; and
 - ii. proposed design for the Change of Scope;
 - iii. proposed modifications, if any, to the Project Completion Schedule of the Project Highway.

For the avoidance of doubt, the Parties expressly agree that, subject to the provisions of Clause 13.4 (ii), the Contract Price shall be increased or decreased, as the case may be, on account of any such Change of Scope.

- (iv) The parties agree that costs and time for implementation of the proposed Change of Scope shall be determined as per the following:
- (a) For works where Schedule of Rates (SOR) of concerned circle of State's Public Works Department are applicable at the Base Date are available, the same shall be applicable for determination of costs. In case of non-availability of Schedule of Rates at the Base Date, the available Schedule of Rates shall be applied by updating the same based on WPI. In case the Contract Price is lower/ higher than the Estimated Project Cost as per RFP, then the SOR rates shall be reduced/ increased in the same proportion accordingly.
 - (b) For item of Works not included in Schedule of Rates as mentioned in sub-para (a) of Clause 13.2 (iv) above, the cost of same shall be derived on the basis of MORTH Standard Data Book and the Authority's Engineer shall determine the prevailing market rates and discount the same considering WPI to achieve the prevailing rate at the Base Date, and for any item in respect of which MORTH Standard Data Book does not provide the requisite details, the Authority's Engineer shall determine the rate in accordance with Good Industry Practice.

For the avoidance of doubt, in case the cost as determined by the Contractor and the Authority reveals a difference of more than 10% (ten per cent), the cost as determined by the Authority shall be considered as final and binding on the Contractor.
 - (c) The design charges shall be considered only for new works or items (i.e. the

Works or items not similar to the works or items in the original scope) @ 1% (one per cent) of cost of such new works or items.

- (d) The costs of existing works or items, which are being changed/ omitted shall also be valued as per above procedure and only net cost shall be considered.
 - (e) The reasonable time for completion of works to be taken under Change of Scope shall be determined by the Authority's Engineer on the basis of Good Industry Practice and if such time exceeds the Scheduled Completion Date, the issue of Completion Certificate shall not be affected or delayed on account of construction of Change of Scope items/ works remaining incomplete on the date of Tests.
- (v) Upon consideration of the detailed proposal submitted by the Contractor under the Clause 13.2 (iii), the Authority, within 15 (fifteen) days of receipt of such proposal, may in its sole discretion either accept such Change of Scope with modifications, if any, and initiate proceedings thereof in accordance with this Article 13 or reject the proposal and inform the Contractor of its decision and shall issue an order (the "**Change of Scope Order**") requiring the Contractor to proceed with the performance thereof.

For the avoidance of doubt, the Parties agree that the Contractor shall not undertake any Change of Scope without the express consent of the Authority, save and except any works necessary for meeting any Emergency, that too with verbal approval of Authority which shall be confirmed in writing in next 3 (three) days. In the event that the Parties are unable to agree, the Authority may:

- (a) issue a Change of Scope Order requiring the Contractor to proceed with the performance thereof at the rates and conditions approved by the Authority till the matter is resolved in accordance with Article 26;
- or
- (b) proceed in accordance with Clause 13.5.
- (vi) The provisions of this Agreement, insofar as they relate to Works and Tests, shall apply mutatis mutandis to the Works undertaken by the Contractor under this Article 13.

13.3. Payment for Change of Scope

Payment for Change of Scope shall be made in accordance with the payment schedule specified in the Change of Scope Order.

13.4. Restrictions on Change of Scope

- (i) No Change of Scope shall be executed unless the Authority has issued the Change of Scope Order save and except any Works necessary for meeting any Emergency.
- (ii) The total value of all Change of Scope Orders shall not exceed 10% (ten per cent) of the Contract Price.
- (iii) Notwithstanding anything to the contrary in this Article 13,if any change is

necessitated because of any default of the Contractor in the performance of its obligations under this Agreement, the same shall not be deemed to be Change of Scope, and shall not result in any adjustment of the Contract Price or the Project Completion Schedule.

13.5. Power of the Authority to undertake Works

- (i) In the event the Parties are unable to agree to the proposed Change of Scope Orders in accordance with Clause 13.2, the Authority may, after giving notice to the Contractor and considering its reply thereto, award such Works or services to any person or agency on the basis of open competitive bidding. It is also agreed that the Contractor shall provide assistance and cooperation to the person or agency who undertakes the works or services hereunder. The Contractor shall not be responsible for rectification of any Defects, but the Contractor shall carry out maintenance of such works after completion of Defect Liability Period of work by other person or agency during the remaining period of this agreement without any extra payment.
- (ii) The Works undertaken in accordance with this Clause 13.5 shall conform to the Specifications and Standards and shall be carried out in a manner that minimises the disruption in operation of the Project Highway. The provisions of this Agreement, insofar as they relate to Works and Tests, shall apply mutatis mutandis to the Works carried out under this Clause 13.5.

Article 14

Maintenance

14.1. Maintenance obligations of the Contractor

- (i) The Contractor shall maintain the Project Highway for a period of [5 (five) / 10 (ten)] years, corresponding to the Defects Liability Period, commencing from the date of the Completion Certificate (the "**Maintenance Period**"). For the performance of its Maintenance obligations, the Contractor shall be paid:
- (a) For flexible pavement with 5 years Maintenance Period including structures: 0.25% of the Contract Price each for the first and second year; 0.5% of the Contract Price each for the third and fourth year and 1% of the Contract Price for the fifth year
 - (b) For rigid pavement with 10 years Maintenance Period including structures: 0.25% of the Contract Price each for the first, second and third year, 0.5% of the Contract Price each for fourth, fifth, sixth and seventh year, and 0.75% of the Contract Price each for eighth, ninth and tenth year.
 - (c) For flexible perpetual pavement with 10 years maintenance period including structures: 0.25% of the Contract Price each for the first, second and third year; 0.5% of the Contract Price each for the fourth, fifth and sixth year. The Contractor shall provide a renewal layer over the existing carriageway in the seventh year from issue of completion certificate. The requirement for this renewal layer shall be worked out based on the survey and investigation of the existing pavement and the cost of such renewal works shall be determined based on the principles defined under clause 13.2(iii). After the laying of the renewal layer in the 7th year, the Contractor shall be paid @ 0.25% of the original Contract Price each for the seventh, eighth, ninth and tenth year.
 - (d) For stand-alone Bridge/ Tunnel works: the contractor shall be paid @ 0.25% of the Contract Price each for the first five years and @ 0.50% of the Contract Price each for the remaining period of five years.

Above amount for the performance of Contractors' Maintenance obligations shall be, inclusive of all taxes. The amount payable for maintenance shall be adjusted to reflect any increase or decrease arising out of variation in WPI to be determined in accordance with the provisions of Clause 19.12. It is further agreed that the Contract Price hereunder shall be reckoned with reference to the amount specified in Clause 19.1 (i), which shall be adjusted to the extent of Change of Scope and the works withdrawn under the provisions of Clause 8.3 (iii), but shall not include any price adjustments in pursuance of Clause 19.10.

- (ii) During the Maintenance Period, the Authority shall provide to the Contractor access to the Site for Maintenance in accordance with this Agreement. The obligations of the Contractor hereunder shall include:

- (a) permitting safe, smooth and uninterrupted flow of traffic on the Project Highway;
 - (b) undertaking routine maintenance including prompt repairs of potholes, cracks, joints, drains, embankments, structures, pavement markings, lighting, road signs and other traffic control devices;
 - (c) undertaking repairs to structures;
 - (d) informing the Authority of any unauthorised use of the Project Highway;
 - (e) informing the Authority of any encroachments on the Project Highway; and
 - (f) operation and maintenance of all communication, patrolling, and administrative systems necessary for the efficient maintenance of the Project Highway in accordance with the provisions of this Agreement.
- (iii) In respect of any Defect or deficiency not specified in Schedule-E, the Contractor shall, at its own cost, undertake repair or rectification in accordance with Good Industry Practice, save and except to the extent that such Defect or deficiency shall have arisen on account of any wilful default or neglect of the Authority or a Force Majeure Event.
- (iv) The Contractor shall remove promptly from the Project Highway any waste materials (including hazardous materials and waste water), rubbish and other debris (including, without limitation, accident debris) and keep the Project Highway in a clean, tidy and orderly condition, and in conformity with the Applicable Laws, Applicable Permits and Good Industry Practice.

14.2. Maintenance Requirements

The Contractor shall ensure and procure that at all times during the Maintenance Period, the Project Highway conforms to the maintenance requirements set forth in Schedule-E (the "**Maintenance Requirements**").

14.3. Maintenance Programme

- (i) The Contractor shall prepare a monthly maintenance programme (the "**Maintenance Programme**") in consultation with the Authority's Engineer and submit the same to the Authority's Engineer not later than 10 (ten) days prior to the commencement of the month in which the Maintenance is to be carried out. For this purpose a joint monthly inspection by the Contractor and the Authority's Engineer shall be undertaken. The Maintenance Programme shall contain the following:
- (a) The condition of the road in the format prescribed by the Authority's Engineer;
 - (b) the proposed maintenance Works; and
 - (c) deployment of resources for maintenance Works.

14.4. Safety, vehicle breakdowns and accidents

- (i) The Contractor shall ensure safe conditions for the Users, and in the event of unsafe conditions, lane closures, diversions, vehicle breakdowns and accidents, it shall follow the relevant operating procedures for removal of obstruction and debris without delay. Such procedures shall conform to the provisions of this Agreement, Applicable Laws, Applicable Permits and Good Industry Practice.
- (ii) The Contractor shall maintain and operate a round-the-clock vehicle rescue post with 1 (one) mobile crane having the capacity to lift a truck with a Gross Vehicle Weight of 30,000 (thirty thousand) kilograms; and such post shall be located at [****]. The Contractor shall promptly remove any damaged vehicles and debris from the Project Highway to enable safe movement of traffic and shall report all accidents to the police forthwith.

14.5. Lane closure

- (i) The Contractor shall not close any lane of the Project Highway for undertaking maintenance works except with the prior written approval of the Authority's Engineer. Such approval shall be sought by the Contractor through a written request to be made at least 10 (ten) days before the proposed closure of lane and shall be accompanied by particulars thereof. Within 5 (five) business days of receiving such request, the Authority's Engineer shall grant permission with such modifications as it may deem necessary and a copy of such permission shall be sent to the Authority.
- (ii) Upon receiving the permission pursuant to Clause 14.5 (i), the Contractor shall be entitled to close the designated lane for the period specified therein, and for all lane closures extending a continuous period of 48 (forty-eight) hours, the Contractor shall, in the event of any delay in re-opening such lane, for every stretch of 250 (two hundred and fifty) metres, or part thereof, pay Damages to the Authority calculated at the rate of 0.1% (zero point one per cent) of the monthly maintenance payment for each day of delay until the lane has been re-opened for traffic. In the event of any delay in re-opening such lanes or in the event of emergency decommissioning and closure to traffic of the whole or any part of the Project Highway due to failure of the Contractor, the Contractor shall pay damages to the Authority at double the above rate, without prejudice the rights of the Authority under this Agreement including Termination thereof.

14.6. Reduction of payment for non-performance of Maintenance obligations

- (i) In the event that the Contractor fails to repair or rectify any Defect or deficiency set forth in Schedule-E within the period specified therein, it shall be deemed as failure of performance of Maintenance obligations by the Contractor and the Authority shall be entitled to effect reduction in monthly lump sum payment for maintenance in accordance with Clause 19.7 and Schedule-M, without prejudice to the rights of the Authority under this Agreement, including Termination thereof.
- (ii) If the nature and extent of any Defect justifies more time for its repair or rectification

than the time specified in Schedule-E, the Contractor shall be entitled to additional time in conformity with Good Industry Practice. Such additional time shall be determined by the Authority's Engineer and conveyed to the Contractor and the Authority with reasons thereof.

14.7. Authority's right to take remedial measures

In the event the Contractor does not maintain and/or repair the Project Highway or any part thereof in conformity with the Maintenance Requirements, the Maintenance Manual or the Maintenance Programme, as the case may be, and fails to commence remedial works within 15 (fifteen) days of receipt of the Maintenance Inspection Report under Clause 15.2 or a notice in this behalf from the Authority or the Authority's Engineer, as the case may be, the Authority shall, without prejudice to its rights under this Agreement including Termination thereof, be entitled to undertake such remedial measures at the cost of the Contractor, and to recover its cost from the Contractor. In addition to recovery of the aforesaid cost, a sum equal to 20% (twenty per cent) of such cost shall be paid by the Contractor to the Authority as Damages.

14.8. Restoration of loss or damage to Project Highway

Save and except as otherwise expressly provided in this Agreement, in the event that the Project Highway or any part thereof suffers any loss or damage during the Maintenance from any cause attributable to the Contractor, the Contractor shall, at its cost and expense, rectify and remedy such loss or damage forthwith so that the Project Highway conforms to the provisions of this Agreement.

14.9. Over riding powers of the Authority

- (i) If in the reasonable opinion of the Authority, the Contractor is in material breach of its obligations under this Agreement and, in particular, the Maintenance Requirements, and such breach is causing or likely to cause material hardship or danger to the Users and pedestrians, the Authority may, without prejudice to any of its rights under this Agreement including Termination thereof, by notice require the Contractor to take reasonable measures immediately for rectifying or removing such hardship or danger, as the case may be.
- (ii) In the event that the Contractor, upon notice under Clause 14.9 (i), fails to rectify or remove any hardship or danger within a reasonable period, the Authority may exercise overriding powers under this Clause 14.9 (ii) and take over the performance of any or all the obligations of the Contractor to the extent deemed necessary by it for rectifying or removing such hardship or danger; provided that the exercise of such overriding powers by the Authority shall be of no greater scope and of no longer duration than is reasonably required hereunder; provided further that any costs and expenses incurred by the Authority in discharge of its obligations hereunder shall be recovered by the Authority from the Contractor, and the Authority shall be entitled to deduct any such costs and expenses incurred from the payments due to the Contractor under Clause 19.7 for the performance of its Maintenance obligations.

- (iii) In the event of a national emergency, civil commotion or any other circumstances specified in Clause 21.3, the Authority may take over the performance of any or all the obligations of the Contractor to the extent deemed necessary by it, and exercise such control over the Project Highway or give such directions to the Contractor as may be deemed necessary; provided that the exercise of such overriding powers by the Authority shall be of no greater scope and of no longer duration than is reasonably required in the circumstances which caused the exercise of such overriding power by the Authority. For the avoidance of doubt, it is agreed that the consequences of such action shall be dealt in accordance with the provisions of Article 21. It is also agreed that the Contractor shall comply with such instructions as the Authority may issue in pursuance of the provisions of this Clause 14.9 (iii), and shall provide assistance and cooperation to the Authority, on a best effort basis, for performance of its obligations hereunder.

14.10. Taking over Certificate

The Maintenance Requirements set forth in Schedule-E having been duly carried out, Maintenance Period as set forth in Clause 14.1 (i) having been expired and Authority's Engineer determining the Tests on Completion of Maintenance to be successful in accordance with Schedule-Q, the Authority will issue Taking Over Certificate to the Contractor substantially in the format set forth in Schedule-R.

Article 15

Supervision and Monitoring during Maintenance

15.1. Inspection by the Contractor

- (i) The Authority's Engineer shall undertake regular inspections to evaluate continuously the compliance with the Maintenance Requirements.
- (ii) The Contractor shall carry out a detailed pre-monsoon inspection of all bridges, culverts and drainage system in accordance with the guidelines contained in IRC: SP35. Report of this inspection together with details of proposed maintenance works as required shall be conveyed to the Authority's Engineer forthwith. The Contractor shall complete the proposed maintenance works before the onset of the monsoon and send a compliance report to the Authority's Engineer. Post monsoon inspection shall be undertaken by the Contractor and the inspection report together with details of any damages observed and proposed action to remedy the same shall be conveyed to the Authority's Engineer forthwith.

15.2. Inspection and payments

- (i) The Authority's Engineer may inspect the Project Highway at any time, but at least once every month, to ensure compliance with the Maintenance Requirements. It shall make a report of such inspection ("Maintenance Inspection Report") stating in reasonable detail the Defects or deficiencies, if any, with particular reference to the Maintenance Requirements, the Maintenance Manual, and the Maintenance Programme, and send a copy thereof to the Authority and the Contractor within 10 (ten) days of such inspection.
- (ii) After the Contractor submits to the Authority's Engineer the Monthly Maintenance Statement for the Project Highway pursuant to Clause 19.6, the Authority's Engineer shall carry out an inspection within 10 (ten) days to certify the amount payable to the Contractor. The Authority's Engineer shall inform the Contractor of its intention to carry out the inspection at least 3 (three) business days in advance of such inspection. The Contractor shall assist the Authority's Engineer in verifying compliance with the Maintenance Requirements.
- (iii) For each case of non-compliance of Maintenance Requirements as specified in the inspection report of the Authority's Engineer, the Authority's Engineer shall calculate the amount of reduction in payment in accordance with the formula specified in Schedule-M.
- (iv) Any deduction made on account of non-compliance will not be paid subsequently even after establishing the compliance thereof. Such deductions will continue to be made every month until the compliance is procured.

15.3. Tests

For determining that the Project Highway conforms to the Maintenance Requirements, the Authority's Engineer shall require the Contractor to carry out, or cause to be carried out, Tests specified by it in accordance with Good Industry Practice. The Contractor shall, with due diligence, carry out or cause to be carried out all such Tests in accordance with the instructions of the Authority's Engineer and furnish the results of such Tests forthwith to the Authority' Engineer.

At any time during Maintenance Period, the Authority may appoint an external technical auditor to conduct an audit of the quality of the Works. The Auditor in the presence of the representatives of the Contractor and the Authority's Engineer shall carry out the Tests and/ or collect samples for testing in the laboratory. The timing, the testing equipment and the sample size of this audit shall be as decided by the Authority. The findings of the audit, to the extent accepted by the Authority, shall be notified to the Contractor and the Authority's Engineer for taking remedial measures. After completion of the remedial measures by the Contractor, the auditor shall undertake a closure audit and this process will continue till the remedial measures have brought the maintenance works into compliance with the Specifications and Standards. The Contractor shall provide all assistance as may be required by the auditor in the conduct of its audit hereunder. Notwithstanding anything contained in this Clause 15.3, the external technical audit shall not affect any obligations of the Contractor or the Authority's Engineer under this Agreement.

15.4. Reports of unusual occurrence

The Contractor shall, during the Maintenance Period, prior to the close of each day, send to the Authority and the Authority's Engineer, by facsimile or e- mail, a report stating accidents and unusual occurrences on the Project Highway relating to the safety and security of the Users and Project Highway. A monthly summary of such reports shall also be sent within 3 (three) business days of the closing of month. For the purposes of this Clause 15.4, accidents and unusual occurrences on the Project Highway shall include:

- (a) accident, death or severe injury to any person;
- (b) damaged or dislodged fixed equipment;
- (c) flooding of Project Highway; and
- (d) any other unusual occurrence.

Article 16

Traffic Regulation

16.1. Traffic regulation by the Contractor

- (i) The Contractor shall take all the required measures and make arrangements for the safety of Users during the Construction and Maintenance of the Project Highway or a Section thereof in accordance with the provisions of MORTH Specifications. It shall provide, erect and maintain all such barricades, signs, markings, flags, and lights as may be required by Good Industry Practice for the safety of the traffic passing through the Section under construction or maintenance.
- (ii) All works shall be carried out in a manner creating least interference to traffic passing through the Project Highway or a Section thereof. In sections where construction or maintenance Works on the carriageway are taken up, the Contractor shall ensure that proper passage is provided for the traffic. Where it is not possible or safe to allow traffic on part width of the carriageway, a temporary diversion of proper specifications shall be constructed by the Contractor at its own cost. 'ROBOTS' may be used for diversion and control of traffic during Construction. The Contractor shall take prior approval of the Authority's Engineer for any proposed arrangement for traffic regulation during Construction and Maintenance, which approval shall not be unreasonably withheld.

Article 17

Defects Liability

17.1. Defects Liability Period

- (i) The Contractor shall be responsible for all the Defects and deficiencies, except usual wear and tear in the Project Highway or any Section thereof, till the expiry of a period of commencing from the date of Completion Certificate (the "Defects Liability Period") as specified below:
- (a) 5 (five) years from the date of completion in case of a road being constructed with flexible pavement;
 - (b) 10 (ten) years from the date of completion in case of road being constructed with rigid pavement;
 - (c) 10 (ten) years from the date of completion in case of road being constructed with flexible pavement using perpetual design;
 - (d) 10 (ten) years from the date of completion in case of all stand-alone structures, e.g. Major Bridges/ and Tunnels;
 - (e) 10 (ten) years from the date of completion for the stretches where new technology/ material has been/ is proposed to be used.

The Defects Liability Period shall commence from the date of the Completion Certificate. For the avoidance of any doubt, any repairs or restoration because of usual wear or tear in the Project Highway or any Section thereof shall form a part of the Maintenance obligations of the Contractor as specified in Article 14.

17.2. Remedying Defects

Save and except as provided in Clause 14.1 (iii), the Contractor shall repair or rectify all Defects and deficiencies observed by the Authority or Authority's Engineer during the Defects Liability Period within a period of 15 (fifteen) days from the date of notice issued by the Authority or Authority's Engineer in this behalf, or within such reasonable period as may be determined by the Authority or Authority's Engineer at the request of the Contractor, in accordance with Good Industry Practice.

17.3. Cost of remedying Defects

Any repair or rectification undertaken in accordance with the provisions of Clause 17.2, including any additional testing, shall be carried out by the Contractor at its own risk and cost, to the extent that such rectification or repair is attributable to:

- (a) the design of the Project;
- (b) Plant, Materials or workmanship not being in accordance with this Agreement and

the Specifications and Standards;

- (c) improper maintenance during construction of the Project Highway by the Contractor; and/ or
- (d) failure by the Contractor to comply with any other obligation under this Agreement.

17.4. Contractor's failure to rectify Defects

If the Contractor fails to repair or rectify such Defect or deficiency within the period specified in Clause 17.2, the Authority shall be entitled to get the same repaired, rectified or remedied at the Contractor's cost to make the Project Highway conform to the Specifications and Standards and the provisions of this Agreement. All costs consequent thereon shall, after due consultation with the Authority and the Contractor, be determined by the Authority's Engineer. The cost so determined and an amount equal to 20% (twenty percent) of the cost as Damages shall be recoverable by the Authority from the Contractor and may be deducted by the Authority from any monies due to the Contractor.

17.5. Extension of Defects Liability Period

The Defects Liability Period shall be deemed to be extended till the identified Defects under Clause 17.2 have been remedied or rectified.

Article 18

Authority's Engineer

18.1. Appointment of the Authority's Engineer

- (i) The Authority shall appoint a firm of Consulting Engineers or a Project Monitoring Committee (PMC) substantially in accordance with the selection criteria set forth in Schedule-N, to be the engineer under this Agreement (the "**Authority's Engineer**"). In unavoidable circumstances, Authority may appoint an officer to act as Authority's Engineer until appointment of a Consulting Engineering firm/ Supervision Consultant/ PMC.
- (ii) The officer in-charge of the Authority (e.g. PD/ RO/ CGM/ Member in the case of NHAI; RO/CE/ADG in the case of MoRTH projects executed through the State PWDs; and PD/ED/Director in the case of NHIDCL) is responsible for the overall supervision and monitoring of the execution of project as the representative of the owner of the project. The Authority's Engineer is appointed to assist the Authority for carrying out the functions as detailed under clause 18.2. As such, an officer of the Authority is vested with all such powers and responsibilities as are enjoined upon the Authority's Engineer and is fully competent to issue any instructions for proper monitoring and supervision of the project, either by himself or through the Authority's Engineer. Instructions issued by the concerned officer of the Authority shall have the same effect as that of the Authority's Engineer in terms of this Agreement. Wherever such concerned officer issues any instructions or notice to the Contractor, he shall endorse a copy thereof to the Authority's Engineer.
- (iii) The Authority's Engineer should be appointed within 10 days from the date of this Agreement or before declaration of Appointed Date, whichever is earlier. The Authority shall notify the appointment or replacement of the Authority's Engineer to the Contractor.
- (iv) The staff of the Authority's Engineer shall include suitably qualified engineers and other professionals who are competent to assist the Authority's Engineer to carry out its duties.

18.2. Duties and authority of the Authority's Engineer

- (i) The Authority's Engineer shall perform the duties and exercise the authority in accordance with the provisions of this Agreement and substantially in accordance with the terms of reference ("**Terms of Reference**" or "**TOR**") set forth in Annexure-I of Schedule N, but subject to obtaining prior written approval of the Authority before determining:
 - (a) any Time Extension;
 - (b) any additional cost to be paid by the Authority to the Contractor;

- (c) the Termination Payment;
 - (d) issuance of Completion Certificate; or
 - (e) any other matter which is not specified in (a), (b), (c) or (d) above and which creates financial liability on either Party.
- (ii) No decision or communication of the Authority's Engineer shall be effective or valid unless it is accompanied by an attested true copy of the approval of the Authority for and in respect of any matter specified in Clause 18.2 (i).
 - (iii) The Authority's Engineer shall submit regular periodic reports, at least once every month, to the Authority in respect of its duties and functions under this Agreement. Such reports shall be submitted by the Authority's Engineer within 10 (ten) days of the beginning of every month. For the avoidance of doubt, the Authority's Engineer shall include in its report, compliance of the recommendations of the Safety Consultant.

18.3. Delegation by the Authority's Engineer

- (i) The Authority's Engineer may, by order in writing, delegate any of his duties and responsibilities to suitably qualified and experienced personnel who are accountable to Authority's Engineer, or may revoke any such delegation, under intimation to the Authority and the Contractor. Provided, however, that the Authority's Engineer shall be responsible and liable for all actions and omissions of such personnel.
- (ii) Any failure of the Authority's Engineer to disapprove any work, Plant or Materials shall not constitute approval, and shall, therefore, not prejudice the right of the Authority to reject the work, Plant or Materials, which is not in accordance with the provisions of this Agreement and the Specifications and Standards.
- (iii) Notwithstanding anything stated in Clause 18.3 (i) above, the Authority's Engineer shall not delegate the authority to refer any matter for the Authority's prior approval wherever required in accordance with the provisions of Clause 18.2.

18.4. Instructions of the Authority's Engineer

- (i) The Authority's Engineer may issue instructions for remedying any Defect(s) to the Contractor. The Contractor shall take such instructions from the Authority's Engineer, or from an assistant to whom appropriate authority has been delegated under Clause 18.3.
- (ii) The instructions issued by the Authority's Engineer shall be in writing. However, if the Authority's Engineer issues any oral instructions to the Contractor, it shall confirm the oral instructions in writing within 2 (two) working days of issuing them.
- (iii) In case the Contractor does not receive the confirmation of the oral instructions within the time specified in Clause 18.4 (ii), the Contractor shall seek the written confirmation of the oral instructions from the Authority's Engineer. The Contractor shall obtain acknowledgement from the Authority's Engineer of the communication seeking

written confirmation. In case of failure of the Authority's Engineer or its delegated assistant to reply to the Contractor within 2 (two) days of the receipt of the communication from the Contractor, the Contractor may not carry out the instructions.

- (iv) In case of any dispute on any of the instructions issued by the delegated assistant, the Contractor may refer the dispute to the Authority's Engineer, who shall then confirm, reverse or vary the instructions within 3 (three) business days of the dispute being referred.

18.5. Determination by the Authority's Engineer

- (i) The Authority's Engineer shall consult with each Party in an endeavour to reach agreement wherever this Agreement provides for the determination of any matter by the Authority's Engineer. If such agreement is not achieved, the Authority's Engineer shall make a fair determination in accordance with this Agreement having due regard to all relevant circumstances. The Authority's Engineer shall give notice to both the Parties of each agreement or determination, with supporting particulars.
- (ii) Each Party shall give effect to each agreement or determination made by the Authority's Engineer in accordance with the provisions of this Agreement. Provided, however, that if any Party disputes any instruction, decision, direction or determination of the Authority's Engineer, the Dispute shall be resolved in accordance with the Dispute Resolution Procedure.

18.6. Remuneration of the Authority's Engineer

The remuneration, costs and expenses of the Authority's Engineer shall be paid by the Authority.

18.7. Termination of the Authority's Engineer

- (i) The Authority may, in its discretion, replace the Authority's Engineer at any time. However, the Authority shall ensure that alternative arrangements for appointment of another Authority's Engineer or designation of its own officer as the Authority Engineer for the intervening period are made simultaneously.
- (ii) If the Contractor has reasons to believe that the Authority's Engineer is not discharging its duties and functions in accordance with the provisions of this Agreement, it may make a written representation to the Authority and seek termination of the appointment of the Authority's Engineer. Upon receipt of such representation, the Authority shall hold a tripartite meeting with the Contractor and the Authority's Engineer and make best efforts for an amicable resolution of the representation. In the event that the appointment of the Authority's Engineer is terminated hereunder, the Authority shall appoint forthwith another Authority's Engineer in accordance with Clause 18.1 and 18.7 (i).

Part IV
Financial Covenants

Article 19

Payments

19.1. Contract Price

- (i) The Authority shall make payments to the Contractor for the Works on the basis of the lump sum price accepted by the Authority in consideration of the obligations specified in this Agreement for an amount of INR------(INR-----)(the "**Contract Price**"), which shall be subject to adjustments in accordance with the provisions of this Agreement. For the avoidance of doubt, the Parties expressly agree that the Contract Price shall not include the cost of Maintenance, which shall be paid separately in accordance with the provisions of Clause 19.7. The Parties further agree that save and except as provided in this Agreement, the Contract Price shall be valid and effective until issue of Completion Certificate.
- (ii) The Contract Price includes all duties, taxes, royalty, cess, charges, and fees that may be levied in accordance with the laws and regulations in force as on the Base Date on the Contractor's equipment, Plant, Materials and supplies acquired for the purpose of this Agreement and on the services performed under this Agreement. Nothing in this Agreement shall relieve the Contractor from its responsibility to pay any tax including any tax that may be levied in India on profits made by it in respect of this Agreement.
- (iii) The Contract Price shall not be adjusted for any change in costs stated in Clause 19.1 (ii) above, except as stated in Clauses 19.10 and 19.17.
- (iv) The Contract Price shall not be adjusted to take account of any unforeseen difficulties or costs, unless otherwise provided for in this Agreement.
- (v) Unless otherwise stated in this Agreement, the Contract Price covers all the Contractor's obligations for the Works under this Agreement and all things necessary for the Construction and the remedying of any Defects in the Project Highway.
- (vi) All payments under this Agreement shall be made in Indian Rupees.

19.2. Advance Payment

- (i) The Authority shall make an interest-bearing advance payment (the "**Advance Payment**") @ "**Bank Rate + 3%**", equal to 10 % (ten percent) of the Contract Price, exclusively for mobilisation expenses. The Advance Payment for mobilisation expenses shall be made in two instalments each equal to 5% (five percent) of the Contract Price. The second 5% (five percent) mobilization advance would be released after submission of utilization certificate by the Contractor for the first 5% (five per cent) advance already released earlier.
- (ii) In addition to above, the Authority shall make an additional interest-bearing Advance Payment against newly purchased key Construction equipment required for the works as per agreed Construction programme and brought to the site, if so requested by the

Contractor subject to the same terms and conditions specified for Advance Payment for mobilisation expenses in this Agreement. The maximum of such advance shall be 5% (five per cent) of the Contract Price against Bank Guarantee. This advance shall be further subject to the condition that:

- (a) such new equipment are considered by the Authority's Engineer to be necessary for the works and
- (b) these new equipment should be procured in the name of Contractor and is verified by Authority's Engineer to have been brought to site.

The Advance Payment for mobilization expenses and for acquisition of key new Construction equipment would be deemed as interest bearing advance at the applicable interest rate (@ "Bank rate + 3%"), to be compounded annually. The interest would be recovered along with the recovery of mobilization Advance Payment as per provision laid down for the mobilization advance recovery.

- (iii) The Contractor may apply to the Authority for the first instalment of the Advance Payment at any time after the Appointed Date, along with an irrevocable and unconditional guarantee from a Bank for an amount equivalent to 110% (one hundred and ten per cent) of such instalment, substantially in the form provided at Annex-III of Schedule-G, to remain effective till the complete and full repayment thereof.
- (iv) At any time, after 60 (sixty) days from the Appointed Date, the Contractor may apply to the Authority for the second instalment of the Advance Payment along with an irrevocable and unconditional guarantee from a Bank for an amount equivalent to 110% (one hundred and ten per cent) of such instalment, substantially in the form provided at Annex-III of Schedule-G, to remain effective till the complete and full repayment thereof.
- (v) The Contractor has the option of splitting the Bank Guarantee against Advance Payment for mobilization expenses into parts, each not less than 2.75% (two point seven five per cent) of the Contract Price. Each part of the guarantee shall remain effective till full repayment of such part advance corresponding to this bank guarantee. Such part of Bank Guarantee shall be returned to the Contractor on recovery under the Agreement of the full amount of such part guarantee within 30 (thirty) days of the said recovery.
- (vi) The Advance Payment shall be paid by the Authority to the Contractor within 15 (fifteen) days of the receipt of its respective requests in accordance with the provisions of this Clause 19.2.
- (vii) The Advance Payment shall be repaid through percentage deductions from the stage payments determined by the Authority's Engineer in accordance with Clause 19.5, as follows:
 - (a) deductions shall commence in the first Stage Payment Statement;

- (b) deductions shall be made at the rate of 15% (fifteen percent) of each Stage Payment Statement until such time as the advance payment has been repaid; provided that the advance payment shall be completely repaid prior to the time when 80% (eighty percent) of the Schedule Construction Period is over;
 - (c) if total certified stage payments (excluding the Advance Payment and deductions and repayments of retention) does not exceed 20% (twenty percent) of the Contract Price within [50% of the Scheduled Construction Period] from the Appointed Date then the Advance Payment including interest shall be recovered by encashment of the Bank Guarantee for the Advance Payment.
- (viii) If the Advance Payment has not been fully repaid prior to Termination under Clause 21.7 or Article 23, as the case may be, the whole of the balance then outstanding shall immediately become due and payable by the Contractor to the Authority. Without prejudice to the provisions of Clause 19.2 (vi), in the event of Termination for Contractor Default, the Advance Payment shall be deemed to carry interest at @ "**Bank Rate+5%**" per annum from the date of Advance Payment to the date of recovery by encashment of the Bank Guarantee for the Advance Payment. For the avoidance of doubt, the aforesaid interest shall be payable on each instalment of the Advance Payment, regardless of whether the instalment or any part thereof has been repaid to the Authority prior to Termination.

19.3. Procedure for estimating the payment for the Works

- (i) The Authority shall make interim payments to the Contractor as certified by the Authority's Engineer on completion of a stage, in a length, number or area as specified and valued in accordance with the proportion of the Contract Price assigned to each item and its stage in Schedule-H.
- (ii) The Contractor shall base its claim for interim payment for the stages completed till the end of the month for which the payment is claimed, valued in accordance with Clause 19.3 (i), supported with necessary particulars and documents in accordance with this Agreement.
- (iii) Any reduction in the Contract Price arising out of Change of Scope or the works withdrawn under Clause 8.3 shall not affect the amounts payable for the items or stage payments thereof which are not affected by such Change of Scope or withdrawal. For avoidance of doubt and by way of illustration, the Parties agree that if the amount assigned to Major Bridges is reduced from Rs. 100 crore to Rs. 80 crore owing to Change of Scope or withdrawal of work, the reduction in payment shall be restricted to relevant payments for Major Bridges only and the payment due in respect of all other stage payments under the item Major Bridges shall not be affected in any manner. The Parties further agree that the adjustments arising out of the aforesaid modifications shall be carried out in a manner that the impact of such modifications is restricted to the said Change of Scope or withdrawal, as the case may be, and does not alter the payments due for and in respect of items or stage payments which do not form part of such Change of Scope or withdrawal.

19.4. Stage Payment Statement for Works

The Contractor shall submit a statement (the "**Stage Payment Statement**"), in 3 (three) copies, by the 7th (seventh) day of the month to the Authority's Engineer in the form set forth in Schedule-O, showing the amount calculated in accordance with Clause 19.3 to which the Contractor considers himself entitled for completed stage(s) of the Works. The Stage Payment Statement shall be accompanied with the progress reports and any other supporting documents. The Contractor shall not submit any claim for payment of incomplete stages of work.

19.5. Stage Payment for Works

- (i) Within 10 (ten) days of receipt of the Stage Payment Statement from the Contractor pursuant to Clause 19.4, the Authority's Engineer shall broadly determine the amount due to the Contractor and recommend the release of 90 (ninety) percent of the amount so determined as part payment against the Stage Payment Statement, pending issue of the Interim Payment Certificate by the Authority's Engineer. Within 10 (ten) days of the receipt of recommendation of the Authority's Engineer, the Authority shall make electronic payment directly to the Contractor's bank account.
- (ii) Within 15 (fifteen) days of the receipt of the Stage Payment Statement referred to in Clause 19.4, the Authority's Engineer shall determine and shall deliver to the Authority and the Contractor an IPC certifying the amount due and payable to the Contractor, after adjusting the payments already released to the Contractor against the said statement. For the avoidance of doubt, the Parties agree that the IPC shall specify all the amounts that have been deducted from the Stage Payment Statement and the reasons therefor.
- (iii) In cases where there is a difference of opinion as to the value of any stage, the Authority's Engineer's view shall prevail and interim payments shall be made to the Contractor on this basis; provided that the foregoing shall be without prejudice to the Contractor's right to raise a Dispute.
- (iv) The Authority's Engineer may, for reasons to be recorded, withhold from payment:
 - (a) the estimated value of work or obligation that the Contractor has failed to perform in accordance with this Agreement and the Authority's Engineer had notified the Contractor; and
 - (b) the estimated cost of rectification of work done being not in accordance with this Agreement.
- (v) Payment by the Authority shall not be deemed to indicate the Authority's acceptance, approval, consent or satisfaction with the work done.

19.6. Monthly Maintenance Statement of the Project Highway

- (i) The Contractor shall submit to the Authority's Engineer a monthly maintenance statement ("**Monthly Maintenance Statement**") in 3 (three) copies by the 7th

(seventh) day of each month in the format set forth in Schedule-O for the Maintenance of the Project Highway during the previous month.

- (ii) The monthly lump sum amount payable for Maintenance shall be 1/12th (one-twelfth) of the annual cost of Maintenance as specified in Clause 14.1 (i).

19.7. Payment for Maintenance of the Project Highway

- (i) Within 15 (fifteen) days of receipt of the Monthly Maintenance Statement from the Contractor pursuant to Clause 19.6, the Authority's Engineer shall verify the Contractor's monthly maintenance statement and certify the amount to be paid to the Contractor taking into account:
 - (a) Compliance with the Maintenance Requirements; and
 - (b) reduction for non-compliance with the Maintenance Requirement in accordance with Clause 19.7 (ii).

The Authority's Engineer shall deliver to the Authority an IPC approving or amending the monthly maintenance statement to reflect the amount due to the Contractor in accordance with this Agreement.

- (ii) Maintenance shall be measured in units of one kilometre each; provided, however, that payment thereof shall be made in fixed monthly amounts in accordance with this Agreement. If the Maintenance Requirements set forth in Schedule-E are not met, reduction in payments shall be made in accordance with the provisions of Schedule-M. The reductions for non-compliance with the Maintenance Requirements shall be applied on the basis of monthly inspections by the Authority's Engineer.
- (iii) The deduction made on account of non-compliance with the Maintenance Requirements shall not be subsequently considered for payment after the compliance is achieved by repair or rectification.
- (iv) The Authority shall pay to the Contractor every quarter any amount due under any IPC under this Clause 19.7. The payment shall be made no later than 30 (thirty) days from the date of submission of the last IPC for the relevant quarter.

19.8. Payment of Damages

- (i) The Contractor may claim Damages due and payable to it in accordance with the provisions of this Agreement.
- (ii) The Authority's Engineer shall issue the IPC within 15 (fifteen) days of the receipt of the claim under Clause 19.8 (i), after making adjustments in accordance with the provisions of this Agreement. The Authority shall pay to the Contractor the amount due under any IPC within a period of 30 (thirty) days from the date of the submission of the claim under this Clause 19.8. In the event of the failure of the Authority to make payment to the Contractor within the specified time, the Authority shall be liable to pay to the Contractor interest thereon and the provisions of Clause 19.9 shall apply mutatis

mutandis thereto.

19.9. Time of payment and interest

- (i) The Authority shall pay to the Contractor any amount due under any payment certificate issued by the Authority's Engineer in accordance with the provisions of this Article 19, or in accordance with any other clause of this Agreement as follows:
 - (a) payment shall be made no later than 30 (thirty) days from the date of submission of the Stage Payment Statement by the Contractor to the Authority's Engineer for certification in accordance with the provisions of Clause 19.4 for an IPC; provided that, in the event the IPC is not issued by the Authority's Engineer within the aforesaid period of 30 (thirty) days, the Authority shall pay the amount shown in the Contractor's Stage Payment Statement and any discrepancy therein shall be added to, or deducted from, the next payment certificate issued to the Contractor; and
 - (b) payment shall be made no later than 30 (thirty) days from the date of submission of the Final Payment Certificate for Works along with the discharge submitted to the Authority's Engineer in accordance with the provisions of Clause 19.15 for certification.
- (ii) In the event of the failure of the Authority to make payment to the Contractor within the time period stated in this Clause 19.9, the Authority shall be liable to pay to the Contractor interest @ 9% (nine per cent) per annum, on all sums remaining unpaid from the date on which the same should have been paid, calculated in accordance with the provisions of sub-Clauses (a) and (b) of Clause 19.9 (i) and till the date of actual payment.

19.10. Price adjustment for the Works

- (i) The amounts payable to the Contractor for Works shall be adjusted in accordance with the provisions of this Clause 19.10
- (ii) Subject to the provisions of Clause 19.10 (iii), the amounts payable to the Contractor for Works, shall be adjusted in the IPC issued by the Authority's Engineer for the increase or decrease in the index cost of inputs for the Works, by the addition or subtraction of the amounts determined by the formulae prescribed in Clause 19.10 (iv).
- (iii) To the extent that full compensation for any increase or decrease in costs to the Contractor is not covered by the provisions of this or other Clauses in this Agreement, the costs and prices payable under this Agreement shall be deemed to include the amounts required to cover the contingency of such other increase or decrease of costs and prices.
- (iv) The Contract Price shall be adjusted for increase or decrease in rates and price of labour, cement, steel, Plant, machinery and spares, bitumen, fuel and lubricants, and other material inputs in accordance with the principles, procedures and formulae specified below:

- (a) Price adjustment shall be applied on completion of the specified stage of the respective item of work in accordance with Schedule-H;
- (b) Adjustment for each item of work/ stage shall be made separately;
- (c) The following expressions and meanings are assigned to the value of the work done:

RW= Value of work done for the completion of a stage under the following items of Schedule-H:

- i. Road works; and
- ii. Other works

BR = Value of work done for the completion of a stage under the items Major Bridges and Structures (Schedule-H)

- (d) Price adjustment for changes in cost shall be paid in accordance with the following formulae:
 - (i) $VRW = 0.85 RW \times [PL \times (LI - LO)/LO + PA \times (AI - AO)/AO + PF \times (FI - FO)/FO + PB \times (BI - BO)/BO + PM \times (MI - MO)/MO + PC \times (CI - CO)/CO + PS \times (SI - SO)/SO]$
 - (ii) $VBR = 0.85 BR \times [PL \times (LI - LO)/LO + PA \times (AI - AO)/AO + PF \times (FI - FO)/FO + PM \times (MI - MO)/MO + PC \times (CI - CO)/CO + PS \times (SI - SO)/SO]$

Where,

VRW = Increase or decrease in the cost of road works/other works during the period under consideration due to changes in the rates for relevant components as stated in sub-paragraph (e).

VBR = Increase or decrease in the cost of Major Bridges and Structures during the period under consideration due to changes in the rates for relevant components as stated in sub-paragraph (e).

PB, PC, PL, PM, and PS are the percentages of bitumen, cement, labour, other materials, and steel/components (including strands and cables) respectively for the relevant item as stated in sub-paragraph (e).

PA is the percentage of Plant, machinery and spares component for the relevant item as stated in sub-paragraph (e).

PF is the percentage of fuel and lubricants for the relevant items as stated in sub-paragraph (e).

A₀ = The wholesale price index as published by the Ministry of Commerce & Industry, Government of India (hereinafter called "WPI") for "Manufacture of

machinery for mining, quarrying and construction" for the month of the Base Date.

- A_I = The WPI for construction machinery for the month three months prior to the month to which the IPC relates.
- B_O = The official retail price of bitumen at the nearest refinery at as per the directions of Authority Engineer on the Base Date.
- B_I = The official retail price of bitumen at nearest refinery at as per the directions of Authority Engineer on the first day of the month three months prior to the month to which the IPC relates.
- C_O = The WPI for Ordinary Portland Cement for the month of the Base Date.
- C_I = The WPI for Ordinary Portland Cement for the month three months prior to the month to which the IPC relates.
- F_O = The official retail price of high speed diesel (HSD) oil at the existing consumer pumps of Indian Oil Corporation ("IOC") in the State of Sikkim on the Base Date.
- F_I = The official retail price of HSD at the existing consumer pumps of IOC in the State of [Haryana] on the first day of the month three months prior to the month to which the IPC relates.
- L_O = The consumer price index for industrial workers for the circle district in the state where work is being executed published by Labour Bureau, Ministry of Labour, Government of India, (hereinafter called "CPI") for the month of the Base Date.
- L_I = The CPI for the month three months prior to the month to which the IPC relates.
- M_O = The WPI for all commodities for the month of the Base Date.
- M_I = The WPI for all commodities for the month three months prior to the month to which the IPC relates.
- S_O = The WPI for Mild Steel -Long Products for the month of the Base Date.
- S_I = The WPI for Mild Steel -Long Products for the month three months prior to the month to which the IPC relates
- (a) The following percentages shall govern the price adjustment of the Contract Price:

Component	Item	
		Road Works

	Earthwork, Granular work, and Other works	Bitumin ous work	Cement Concrete Pavement	Culverts, minor bridges and other	
Labour (PL)	[20%]	[20%]	[20%]	[15%]	[15%]
Cement (PC)	[5%]	Nil	[20%]	[15%]	[15%]
Steel (PS)	Nil	Nil	Nil	[15%]	[20%]
Bitumen (PB)	Nil	[15%]	Nil	Nil	Nil
Fuel and lubricants (PF)	[10%]	[10%]	[10%]	[10%]	[10%]
Other Materials (PM)	[50%]	[40%]	[35%]	[30%]	[25%]
Plant, machinery and spares. (PA)	[15%]	[15%]	[15%]	[15%]	[15%]
Total	100%	100%	100%	100%	100%

19.11. Restrictions on price adjustment

Price adjustment shall be due and payable only in respect of the stages of Works for which the Stage Payment Statement has been submitted by the Contractor no later than 30 (thirty) days from the date of the applicable Project Milestone or the Scheduled Completion Date, as the case may be, including any Time Extension granted there for in accordance with the provisions of this Agreement. For the avoidance of doubt, in the event of submission of any Stage Payment Statement after the period specified herein, price adjustment shall be applicable until the date of the respective Project Milestone or the Scheduled Completion Date, as the case may be.

19.12. Price adjustment for Maintenance of Project Highway

Lump sum payment for Maintenance shall be adjusted every quarter for changes in rates and prices of various inputs in accordance with the formula given below:

$$V = P \times [(W_i - W_o)/W_a]$$

Where

V= Increase or decrease in the quarterly lump sum payment

P= Quarterly lump sum payment due to the Contractor after adjusting any reduction in payment for non-compliance of the Maintenance Requirements

W₀= The wholesale price index (all commodities) for the month of the Base Date.

W₁= The wholesale price index (all commodities) for the first day of the quarter under consideration for determining the price adjustment.

19.13. Final Payment Statement

- (i) Within 60 (sixty) days after receiving the Completion Certificate under Clause 12.2, the Contractor shall submit to the Authority's Engineer for consideration 6 (six) copies of a Final Payment Statement (the "**Final Payment Statement**") for Works, with supporting documents showing in detail, in the form prescribed by the Authority's Engineer:
- (a) the summary of Contractor's Stage Payment claims for Works as submitted in accordance with Clause 19.4;
 - (b) the amounts received from the Authority against each claim; and
 - (c) any further sums which the Contractor considers due to it from the Authority.

If the Authority's Engineer disagrees with or cannot verify any part of the Final Payment Statement, the Contractor shall submit such further information as the Authority's Engineer may reasonably require. The Authority's Engineer shall deliver to the Authority:

- i. an IPC for those parts of the Final Payment Statement which are not in dispute, along with a list of disputed items which shall then be settled in accordance with the provisions of Article 26; or
 - ii. a Final Payment Certificate in accordance with Clause 19.15 if there are no disputed items.
- (ii) If the Authority's Engineer does not prescribe the form referred to in Clause 19.13 (i) within 15 (fifteen) of the date of issue of the Completion Certificate, the Contractor shall submit the statement in such form as it deems fit.

19.14. Discharge

Upon submission of the Final Payment Statement for Works under Clause 19.13, the Contractor shall give to the Authority, with a copy to the Authority's Engineer, a written discharge confirming that the total of the Final Payment Statement represents full and final settlement of all monies due to the Contractor in respect of this Agreement for all the Works arising out of this Agreement, except for any monies due to either Party on account of any Defect. Provided that such discharge shall become effective only after the payment due has been made in accordance with the Final Payment Certificate issued pursuant to Clause 19.15.

19.15. Final Payment Certificate

- (i) Within 30 (thirty) days after receipt of the Final Payment Statement for Works under Clause 19.13, and the written discharge under Clause 19.14, and there being no disputed items of claim, the Authority's Engineer shall deliver to the Authority, with a copy to the Contractor, a final payment certificate (the "**Final Payment Certificate**") stating the amount which, in the opinion of the Authority's Engineer, is finally due under this Agreement or otherwise. For the avoidance of doubt, before issuing the Final Payment Certificate,

the Authority's Engineer shall ascertain from the Authority all amounts previously paid by the Authority and for all sums to which the Authority is entitled, the balance, if any, due from the Authority to the Contractor or from the Contractor to the Authority, as the case may be.

- (ii) The Authority shall, in accordance with the provisions of Clause 19.9, pay to the Contractor the amount which is stated as being finally due in the Final Payment Certificate.

19.16. Final payment statement for Maintenance

- (i) Within 30 (thirty) days after completion of the Maintenance Period, the Contractor shall submit to the Authority's Engineer 6 (six) copies of the final payment statement for Maintenance of the Project Highway, with supporting documents showing the details set forth below in the form prescribed by the Authority's Engineer:
 - (a) the total amount claimed in accordance with clause 19.7 (i) and
 - (b) any sums which the Contractor considers to be due to it, with supporting documents.
- (ii) The Authority's Engineer shall certify final payment within 30 (thirty) days of the receipt of the final payment statement of Maintenance under Clause 19.16 (i), segregating the items of amount payable from the items of amount disallowed. The Authority shall make payment on the basis of the final payment authorised by the Authority's Engineer within a period of 30 (thirty) days of the receipt of the Final Payment Statement from the Authority's Engineer.
- (iii) If the Authority's Engineer does not prescribe the form within 15 (fifteen) days of the date of issue of the Completion Certificate, the Contractor shall submit the statement in such form as it deems fit.

19.17. Change in law

- (i) If as a result of Change in Law, the Contractor suffers any additional costs in the execution of the Works or in relation to the performance of its other obligations under this Agreement, the Contractor shall, within 15 (fifteen) days from the date it becomes reasonably aware of such addition in cost, notify the Authority with a copy to the Authority's Engineer of such additional cost due to Change in Law.
- (ii) If as a result of Change in Law, the Contractor benefits from any reduction in costs for the execution of this Agreement or in accordance with the provisions of this Agreement, either Party shall, within 15 (fifteen) days from the date it becomes reasonably aware of such reduction in cost, notify the other Party with a copy to the Authority's Engineer of such reduction in cost due to Change in Law.
- (iii) The Authority's Engineer shall, within 15 (fifteen) days from the date of receipt of the notice from the Contractor or the Authority, determine any addition or reduction to the Contract Price, as the case may be, due to the Change in Law.

19.18. Correction of Interim Payment Certificates

The Authority's Engineer may by an Interim Payment Certificate make any correction or modification in any previous Interim Payment Certificate issued by the Authority's Engineer.

19.19. Authority's claims

If the Authority considers itself to be entitled to any payment from the Contractor under any Clause of this Agreement, it shall give notice and particulars to the Contractor 20 (twenty) days before making the recovery from any amount due to the Contractor, and shall take into consideration the representation, if any, made by the Contractor in this behalf, before making such recovery.

19.20. Bonus for early completion

In the event that the Project Completion Date occurs prior to the Scheduled Completion Date, the Contractor shall be entitled to receive a payment of bonus equivalent to 0.03% (zero point zero three per cent) of the Contract Price for each day by which the Project Completion Date precedes the Scheduled Completion Date, but subject to a maximum of 5% (five per cent) of the Contract Price. Provided, however, that the payment of bonus, if any, shall be made only after the issue of the Completion Certificate. For the avoidance of the doubt, the Parties agree that for the purpose of determining the bonus payable hereunder, the works shall always be deemed to be as specified in this Contract Agreement but excluding the works deemed to be deleted from the scope of work under clause 8.3 of this Contract Agreement and the Contract Price shall always be deemed to be the amount specified in Clause 19.1 (i) after excluding the Contract Price of the Works deemed to be deleted from the Scope of Work under clause 8.3 of this Contract Agreement, and shall exclude any revision thereof for any reason. The Parties also agree that bonus shall be payable only if each work for which Time Extension has been granted is completed within respective Extended Time.

Article 20

Insurance

20.1. Insurance for Works and Maintenance

- (i) The Contractor shall effect and maintain at its own cost the insurances specified in Schedule-P and as per the requirements under the Applicable Laws.
- (ii) Subject to the provisions of Clause 21.6, the Authority and the Contractor shall, in accordance with its obligations as provided for in this Agreement, be liable to bear the cost of any loss or damage that does not fall within the scope of this Article 20 or cannot be recovered from the insurers.
- (iii) Subject to the exceptions specified in Clause 20.1 (iv) below, the Contractor shall, save and except as provided for in this Agreement, fully indemnify, hold harmless and defend the Authority from and against any and all losses, damages, costs, charges and/or claims with respect to:
 - (a) the death of or injury to any person; or
 - (b) the loss of or damage to any property (other than the Works); that may arise out of or in consequence of any breach by the Contractor of this Agreement during the execution of the Works or the remedying of any Defects therein.
- (iv) Notwithstanding anything stated above in Clause 20.1 (iii), the Authority shall fully indemnify the Contractor from and against any and all losses, damages, costs, charges, proceedings and/or claims arising out of or with respect to:
 - (a) the use or occupation of land or any part thereof by the Authority;
 - (b) the right of the Authority to execute the Works, or any part thereof, on, over, under, in or through any land;
 - (c) the damage to property which is the unavoidable result of the execution and completion of the Works, or the remedying of any Defects therein, in accordance with this Agreement; and
 - (d) the death of or injury to persons or loss of or damage to property resulting from any act or neglect of the Authority, its agents, servants or other contractors, not being employed by the Contractor.

Provided that, in the event of any injury or damage as a result of the contributory negligence of the Contractor, the Authority shall be liable to indemnify the Contractor from and against any and all losses, damages, costs, charges, proceedings and/or claims to the extent as may be proportionately determined to be the liability of the Authority, its servants or agents or other contractors not associated with the Contractor in such injury or damage.

- (v) Without prejudice to the obligations of the Parties as specified under Clauses 20.1 (iii) and 20.1 (iv), the Contractor shall maintain or effect such third party insurances as may be required under the Applicable Laws.
- (vi) The Contractor shall provide to the Authority, within 30 days of the Appointed Date, evidence of professional liability insurance maintained by its Design Director and/or consultants to cover the risk of professional negligence in the design of Works. The professional liability coverage shall be for a sum of not less than [3% (three per cent)] of the Contract Price and shall be maintained until the end of the Defects Liability Period.

20.2. Notice to the Authority

No later than 15 (fifteen) days after the date of this Agreement, the Contractor shall by notice furnish to the Authority, in reasonable detail, information in respect of the insurances that it proposes to effect and maintain in accordance with this Article 20. Within 15 (fifteen) days of receipt of such notice, the Authority may require the Contractor to effect and maintain such other insurances as may be necessary pursuant hereto, and in the event of any difference or disagreement relating to any such insurance, the Dispute Resolution Procedure shall apply.

20.3. Evidence of Insurance Cover

- (i) All insurances obtained by the Contractor in accordance with this Article 20 shall be maintained with insurers on terms consistent with Good Industry Practice. Within 10 (ten) days from the Appointed Date, the Contractor shall furnish to the Authority notarised true copies of the certificate (s) of insurance, copies of insurance policies and premia payment receipts in respect of such insurance, and no such insurance shall be cancelled, modified, or allowed to expire or lapse until the expiration of at least 45 (forty-five) days after notice of such proposed cancellation, modification or non-renewal has been delivered by the Contractor to the Authority. The Contractor shall act in accordance with the directions of the Authority. Provided that the Contractor shall produce to the Authority the insurance policies in force and the receipts for payment of the current premia.
- (ii) The Contractor shall ensure the adequacy of the insurances at all times in accordance with the provisions of this Agreement.

20.4. Remedy for failure to insure

If the Contractor shall fail to effect and keep in force all insurances for which it is responsible pursuant hereto, the Authority shall have the option to either keep in force any such insurances, and pay such premia and recover the costs thereof from the Contractor, or in the event of computation of a Termination Payment, treat an amount equal to the Insurance Cover as deemed to have been received by the Contractor.

20.5. Waiver of subrogation

All insurance policies in respect of the insurance obtained by the Contractor pursuant to this Article 20 shall include a waiver of any and all rights of subrogation or recovery of the

insurers there under against, inter alia, the Authority, and its assigns, successors, undertakings and their subsidiaries, Affiliates, employees, insurers and underwriters, and of any right of the insurers to any set-off or counterclaim or any other deduction, whether by attachment or otherwise, in respect of any liability of any such person insured under any such policy or in any way connected with any loss, liability or obligation covered by such policies of insurance.

20.6. Contractor's waiver

The Contractor hereby further releases, assigns and waives any and all rights of subrogation or recovery against, inter alia, the Authority and its assigns, undertakings and their subsidiaries, Affiliates, employees, successors, insurers and underwriters, which the Contractor may otherwise have or acquire in or from or in any way connected with any loss, liability or obligation covered by policies of insurance maintained or required to be maintained by the Contractor pursuant to this Agreement (other than third party liability insurance policies) or because of deductible clauses in or inadequacy of limits of any such policies of insurance.

20.7. Cross liabilities

Any such insurance maintained or effected in pursuance of this Article 20 shall include a cross liability clause such that the insurance shall apply to the Contractor and to the Authority as separately insured.

20.8. Accident or injury to workmen

Notwithstanding anything stated in this Agreement, it is hereby expressly agreed between the Parties that the Authority shall not be liable for or in respect of any damages or compensation payable to any workman or other person in the employment of the Contractor or Sub-contractor, save and except as for death or injury resulting from any act, omission or wilful default of the Authority, its agents or servants. The Contractor shall indemnify and keep indemnified the Authority from and against all such claims, proceedings, damages, costs, charges, and expenses whatsoever in respect of the above save and except for those acts, omissions or wilful defaults for which the Authority shall be liable.

20.9. Insurance against accident to workmen

The Contractor shall effect and maintain during the Agreement such insurances as may be required to insure the Contractor's personnel and any other persons employed by it on the Project Highway from and against any liability incurred in pursuance of this Article 20. Provided that for the purposes of this Clause 20.9, the Contractor's personnel/any person employed by the Contractor shall include the Subcontractor and its personnel. It is further provided that, in respect of any persons employed by any Sub-contractor, the Contractor's obligations to insure as aforesaid under this Clause 20.9 shall be discharged if the Sub-contractor shall have insured against any liability in respect of such persons in such manner that the Authority is indemnified under the policy. The Contractor shall require such Sub-contractor to produce before the Authority, when required, such policy of insurance and the receipt for payment of the current premium within 10 (ten) days of such demand being

made by the Authority.

20.10. Application of insurance proceeds

The proceeds from all insurance claims, except for life and injury, shall be applied for any necessary repair, reconstruction, reinstatement, replacement, improvement, delivery or installation of the Project Highway and the provisions of this Agreement in respect of construction of works shall apply mutatis mutandis to the works undertaken out of the proceeds of insurance.

20.11. Compliance with policy conditions

Each Party hereby expressly agrees to fully indemnify the other Party from and against all losses and claims arising from its failure to comply with conditions imposed by the insurance policies effected in accordance with this Agreement.

20.12. General Requirements of Insurance Policies

The Contractor must:

- (a) immediately deposit copies of the policies or certificates of any insurance which it is required to effect under the Contract, together with receipts for the premiums;
- (b) effect all insurances for which the Contractor is responsible with an insurer approved by the Authority;
- (c) make no material changes to the terms of any insurance without the Authority's approval;
- (d) in all respects comply with any conditions stipulated in the insurance policies which the Contractor is required to effect under the Agreement or which the Authority has effected in relation to the Facility and notified to the Contractor; and shall provide all assistance to the Authority in the application for, and finalization of, such comprehensive insurance package;
- (e) regardless of the extent of settlement of claims by the underwriters or the time taken for settlement of claims, the Contractor shall make good any loss, or damage at its own cost promptly;
- (f) provide all assistance to the Authority in the application for, and finalization of, such comprehensive insurance package;
- (g) pay the Contractor's share of the insurance premiums for insurance premiums allocated under such comprehensive insurance package policy to the insurances directly to the insurance provider promptly on demand. In case the Contractor fails to make such payment in time, the Authority may elect to pay the Contractor's share and adjust it against amounts payable to the Contractor under this Agreement;

- (h) in the case of occurrence of any event leading to an insurance claim, promptly follow the procedures specified by the insurance provider, and provide full cooperation and access to the insurance provider or its representative, to settle the claim expeditiously;
- (i) require all the Sub-Contractors providing equipment and materials or services to the Contractor or the Authority to obtain, maintain and keep in force during the time in which they are involved in the performance of the Works hereunder insurance coverage consistent with the Contractor's insurance obligations hereunder and the Contractor shall also be responsible for fulfillment of this requirement; and
- (j) the required insurance coverage and the Contractor's obligations-referred to shall in no way affect or limit the Contractor's liability with respect to its performance of the Works. Nothing in this Section shall limit or relieve the Contractor of its liabilities and obligations under this Agreement.

Part V
Force Majeure and Termination

Article 21

Force Majeure

21.1. Force Majeure

As used in this Agreement, the expression "Force Majeure" or "Force Majeure Event" shall mean occurrence in India of any or all of Non-Political Event, Indirect Political Event and Political Event, as defined in Clauses 21.2, 21.3 and 21.4 respectively, if it affects the performance by the Party claiming the benefit of Force Majeure (the "Affected Party") of its obligations under this Agreement and which act or event (i) is beyond the reasonable control of the Affected Party, and (ii) the Affected Party could not have prevented or overcome by exercise of due diligence and following Good Industry Practice, and (iii) has Material Adverse Effect on the Affected Party.

21.2. Non-Political Event

A Non-Political Event shall mean one or more of the following acts or events:

- (a) act of God, epidemic, extremely adverse weather conditions, lightning, earthquake, landslide, cyclone, flood, volcanic eruption, chemical or radioactive contamination or ionising radiation, fire or explosion (to the extent of contamination or radiation or fire or explosion originating from a source external to the Site);
- (b) strikes or boycotts (other than those involving the Contractor, Sub contractors or their respective employees/ representatives, or attributable to any act or omission of any of them) interrupting supplies and services to the Project Highway for a continuous period of 24 (twenty-four) hours and an aggregate period exceeding 10 (ten) days in an Accounting Year, and not being an Indirect Political Event set forth in Clause 21.3;
- (c) any failure or delay of a Sub-contractor but only to the extent caused by another Non-Political Event;
- (d) any judgement or order of any court of competent jurisdiction or statutory authority made against the Contractor in any proceedings for reasons other than (i) failure of the Contractor to comply with any Applicable Law or Applicable Permit, or (ii) on account of breach of any Applicable Law or Applicable Permit or of any contract, or (iii) enforcement of this Agreement, or (iv) exercise of any of its rights under this Agreement by the Authority;
- (e) the discovery of geological conditions, toxic contamination or archaeological remains on the Site that could not reasonably have been expected to be discovered through a site inspection; or
- (f) any event or circumstances of a nature analogous to any of the foregoing.

21.3. Indirect Political Event

An Indirect Political Event shall mean one or more of the following acts or events:

- (a) an act of war (whether declared or undeclared), invasion, armed conflict or act of foreign enemy, blockade, embargo, riot, insurrection, terrorist or military action, civil commotion or politically motivated sabotage;
- (b) industry-wide or State-wide strikes or industrial action for a continuous period of 24 (twenty-four) hours and exceeding an aggregate period of 10 (ten) days in an Accounting Year;
- (c) any civil commotion, boycott or political agitation which prevents construction of the Project Highway by the Contractor for an aggregate period exceeding 10 (ten) days in an Accounting Year;
- (d) any failure or delay of a Sub-contractor to the extent caused by any Indirect Political Event;
- (e) any Indirect Political Event that causes a Non-Political Event; or
- (f) any event or circumstances of a nature analogous to any of the foregoing.

21.4. Political Event

A Political Event shall mean one or more of the following acts or events by or on account of any Government Instrumentality:

- (a) Change in Law, only if consequences thereof cannot be dealt with under and in accordance with the provisions of Clause 19.17;
- (b) compulsory acquisition in national interest or expropriation of any Project Assets or rights of the Contractor or of the Sub-Contractors;
- (c) unlawful or unauthorised or without jurisdiction revocation of, or refusal to renew or grant without valid cause, any clearance, licence, permit, authorisation, no objection certificate, consent, approval or exemption required by the Contractor or any of the Sub-contractors to perform their respective obligations under this Agreement; provided that such delay, modification, denial, refusal or revocation did not result from the Contractor's or any Sub-contractor's inability or failure to comply with any condition relating to grant, maintenance or renewal of such clearance, licence, authorisation, no objection certificate, exemption, consent, approval or permit;
- (d) any failure or delay of a Sub-contractor but only to the extent caused by another Political Event; or
- (e) any event or circumstances of a nature analogous to any of the foregoing.

21.5. Duty to report Force Majeure Event

- (i) Upon occurrence of a Force Majeure Event, the Affected Party shall by notice report such occurrence to the other Party forthwith. Any notice pursuant hereto shall include full particulars of:
 - (a) the nature and extent of each Force Majeure Event which is the subject of any claim for relief under this Article 21 with evidence in support thereof;
 - (b) the estimated duration and the effect or probable effect which such Force Majeure Event is having or will have on the Affected Party's performance of its obligations under this Agreement;
 - (c) the measures which the Affected Party is taking or proposes to take for alleviating the impact of such Force Majeure Event; and
 - (d) any other information relevant to the Affected Party's claim.
- (ii) The Affected Party shall not be entitled to any relief for or in respect of a Force Majeure Event unless it shall have notified the other Party of the occurrence of the Force Majeure Event as soon as reasonably practicable, and in any event no later than 10 (ten) days after the Affected Party knew, or ought reasonably to have known, of its occurrence, and shall have given particulars of the probable material effect that the Force Majeure Event is likely to have on the performance of its obligations under this Agreement.
- (iii) For so long as the Affected Party continues to claim to be materially affected by such Force Majeure Event, it shall provide the other Party with regular (and not less than weekly) reports containing information as required by Clause 21.5 (i), and such other information as the other Party may reasonably request the Affected Party to provide.

21.6. Effect of Force Majeure Event on the Agreement

- (i) Upon the occurrence of any Force Majeure after the Appointed Date, the costs incurred and attributable to such event and directly relating to this Agreement (the "**Force Majeure costs**") shall be allocated and paid as follows:
 - (a) upon occurrence of a Non-Political Event, the Parties shall bear their respective Force Majeure costs and neither Party shall be required to pay to the other Party any costs thereof;
 - (b) upon occurrence of an Indirect Political Event, all Force Majeure costs attributable to such Indirect Political Event, and not exceeding the Insurance Cover for such Indirect Political Event, shall be borne by the Contractor, and to the extent Force Majeure costs exceed such Insurance Cover, one half of such excess amount shall be reimbursed by the Authority to the Contractor for the Force Majeure events; and
 - (c) upon occurrence of a Political Event, all Force Majeure costs attributable to such Political Event shall be reimbursed by the Authority to the Contractor.

- (d) For the avoidance of doubt, Force Majeure costs may include costs directly attributable to the Force Majeure Event, but shall not include debt repayment obligations, if any, of the Contractor.
- (ii) Save and except as expressly provided in this Article 21, neither Party shall be liable in any manner whatsoever to the other Party in respect of any loss, damage, cost, expense, claims, demands and proceedings relating to or arising out of occurrence or existence of any Force Majeure Event or exercise of any right pursuant hereto.
- (iii) Upon the occurrence of any Force Majeure Event during the Construction Period, the Project Completion Schedule for and in respect of the affected Works shall be extended on a day for day basis for such period as performance of the Contractor's obligations is affected on account of the Force Majeure Event or its subsisting effects.

21.7. Termination Notice for Force Majeure Event

- (i) If a Force Majeure Event subsists for a period of 60 (sixty) days or more within a continuous period of 120 (one hundred and twenty) days, either Party may in its discretion terminate this Agreement by issuing a Termination Notice to the other Party without being liable in any manner whatsoever, save as provided in this Article 21, and upon issue of such Termination Notice, this Agreement shall, notwithstanding anything to the contrary contained herein, stand terminated forthwith; provided that before issuing such Termination Notice, the Party intending to issue the Termination Notice shall inform the other Party of such intention and grant 15 (fifteen) days' time to make a representation, and may after the expiry of such 15 (fifteen) days period, whether or not it is in receipt of such representation, in its sole discretion issue the Termination Notice.

21.8. Termination Payment for Force Majeure Event

- (i) In the event of this Agreement being terminated on account of a Non-Political Event, the Termination Payment shall be an amount equal to the sum payable under Clause 23.5.
Provided that in the event Termination occurs during the Maintenance Period, the Authority's Engineer shall only determine the value of Works associated with Maintenance.
- (ii) If Termination is on account of an Indirect Political Event, the Termination Payment shall include:
 - (a) any sums due and payable under Clause 23.5; and
 - (b) the reasonable cost, as determined by the Authority's Engineer, of the Plant and Materials procured by the Contractor and transferred to the Authority for use in Construction or Maintenance, only if such Plant and Materials are in conformity with the Specifications and Standards;

Provided that in the event Termination occurs during the Maintenance Period, the Authority's Engineer shall only determine the value of Works associated with Maintenance.

- (iii) If Termination is on account of a Political Event, the Authority shall make a Termination Payment to the Contractor in an amount that would be payable under Clause 23.6 (ii) as if it were an Authority Default.

21.9. Dispute resolution

In the event that the Parties are unable to agree in good faith about the occurrence or existence of a Force Majeure Event, such Dispute shall be finally settled in accordance with the Dispute Resolution Procedure; provided that the burden of proof as to the occurrence or existence of such Force Majeure Event shall be upon the Party claiming relief and/ or excuse on account of such Force Majeure Event.

21.10. Excuse from performance of obligations

If the Affected Party is rendered wholly or partially unable to perform its obligations under this Agreement because of a Force Majeure Event, it shall be excused from performance of such of its obligations to the extent it is unable to perform on account of such Force Majeure Event; provided that:

- (a) the suspension of performance shall be of no greater scope and of no longer duration than is reasonably required by the Force Majeure Event;
- (b) the Affected Party shall make all reasonable efforts to mitigate or limit damage to the other Party arising out of or as a result of the existence or occurrence of such Force Majeure Event and to cure the same with due diligence; and
- (c) when the Affected Party is able to resume performance of its obligations under this Agreement, it shall give to the other Party notice to that effect and shall promptly resume performance of its obligations hereunder.

Article 22

Suspension of Contractor's Rights

22.1. Suspension upon Contractor Default

Upon occurrence of a Contractor Default, the Authority shall be entitled, without prejudice to its other rights and remedies under this Agreement including its rights of Termination hereunder, to (i) suspend carrying out of the Works or Maintenance or any part thereof, and (ii) carry out such Works or Maintenance itself or authorise any other person to exercise or perform the same on its behalf during such suspension (the "Suspension"). Suspension hereunder shall be effective forthwith upon issue of notice by the Authority to the Contractor and may extend up to a period not exceeding 90 (ninety) days from the date of issue of such notice.

22.2. Authority to act on behalf of Contractor

During the period of Suspension hereunder, all rights and liabilities vested in the Contractor in accordance with the provisions of this Agreement shall continue to vest therein and all things done or actions taken, including expenditure incurred by the Authority for discharging the obligations of the Contractor under and in accordance with this Agreement shall be deemed to have been done or taken for and on behalf of the Contractor and the Contractor undertakes to indemnify the Authority for all costs incurred during such period. The Contractor hereby licences and sub-licences respectively, the Authority or any other person authorised by it under Clause 22.1 to use during Suspension, all Intellectual Property belonging to or licensed to the Contractor with respect to the Project Highway and its design, engineering, construction and maintenance, and which is used or created by the Contractor in performing its obligations under the Agreement.

22.3. Revocation of Suspension

- (i) In the event that the Authority shall have rectified or removed the cause of Suspension within a period not exceeding 60 (sixty) days from the date of Suspension, it shall revoke the Suspension forthwith and restore all rights of the Contractor under this Agreement. For the avoidance of doubt, the Parties expressly agree that the Authority may, in its discretion, revoke the Suspension at any time, whether or not the cause of Suspension has been rectified or removed hereunder.
- (ii) Upon the Contractor having cured the Contractor Default within a period not exceeding 60 (sixty) days from the date of Suspension, the Authority shall revoke the Suspension forthwith and restore all rights of the Contractor under this Agreement.

22.4. Termination

- (i) At any time during the period of Suspension under this Article 22, the Contractor may by notice require the Authority to revoke the Suspension and issue a Termination Notice. The Authority shall, within 15 (fifteen) days of

receipt of such notice, terminate this Agreement under and in accordance with Article 23.

- (ii) Notwithstanding anything to the contrary contained in this Agreement, in the event that Suspension is not revoked within 90 (ninety) days from the date of Suspension hereunder, the Agreement shall, upon expiry of the aforesaid period, be deemed to have been terminated by mutual agreement of the Parties and all the provisions of this Agreement shall apply, mutatis mutandis, to such Termination as if a Termination Notice had been issued by the Authority upon occurrence of a Contractor Default.

Article 23

Termination

23.1. Termination for Contractor Default

- (i) Save as otherwise provided in this Agreement, in the event that any of the defaults specified below shall have occurred, and the Contractor fails to cure the default within the Cure Period set forth below, or where no Cure Period is specified, then within a Cure Period of 60 (sixty) days, the Contractor shall be deemed to be in default of this Agreement (the "**Contractor Default**"), unless the default has occurred solely as a result of any breach of this Agreement by the Authority or due to Force Majeure. The defaults referred to herein shall include:
- (a) the Contractor fails to provide, extend or replenish, as the case may be, the Performance Security in accordance with this Agreement;
 - (b) after the replenishment or furnishing of fresh Performance Security in accordance with Clause 7.3, the Contractor fails to cure, within a Cure Period of 30 (thirty) days, the Contractor Default for which the whole or part of the Performance Security was appropriated;
 - (c) the Contractor does not achieve the latest outstanding Project Milestone due in accordance with the provisions of Schedule-J, subject to any Time Extension, and continues to be in default for 45 (forty five) days;
 - (d) the Contractor abandons or manifests intention to abandon the construction or Maintenance of the Project Highway without the prior written consent of the Authority;
 - (e) the Contractor fails to proceed with the Works in accordance with the provisions of Clause 10.1 or stops Works and/or the Maintenance for 30 (thirty) days without reflecting the same in the current programme and such stoppage has not been authorised by the Authority's Engineer;
 - (f) the Project Completion Date does not occur within the period specified in Schedule-J for the Scheduled Completion Date, or any extension thereof;
 - (g) the Contractor fails to rectify any Defect, the non-rectification of which shall have a Material Adverse Effect on the Project, within the time specified in this Agreement or as directed by the Authority's Engineer;
 - (h) the Contractor subcontracts the Works or any part thereof in violation of this Agreement or assigns any part of the Works or the Maintenance without the prior approval of the Authority;
 - (i) the Contractor creates any Encumbrance in breach of this Agreement;

- (j) an execution levied on any of the assets of the Contractor has caused a Material Adverse Effect;
- (k) the Contractor is adjudged bankrupt or insolvent, or if a trustee or receiver is appointed for the Contractor or for the whole or material part of its assets that has a material bearing on the Project;
- (l) the Contractor has been, or is in the process of being liquidated, dissolved, wound-up, amalgamated or reconstituted in a manner that would cause, in the reasonable opinion of the Authority, a Material Adverse Effect;
- (m) a resolution for winding up or insolvency of the Contractor is passed, or any petition for winding up or insolvency of the Contractor is admitted by a court of competent jurisdiction and a provisional liquidator or receiver or interim resolution professional, as the case may be, is appointed and such order has not been set aside within 90 (ninety) days of the date thereof or the Contractor is ordered to be wound up by court except for the purpose of amalgamation or reconstruction; provided that, as part of such amalgamation or reconstruction, the entire property, assets and undertaking of the Contractor are transferred to the amalgamated or reconstructed entity and that the amalgamated or reconstructed entity has unconditionally assumed the obligations of the Contractor under this Agreement; and provided that:
 - i. the amalgamated or reconstructed entity has the capability and experience necessary for the performance of its obligations under this Agreement; and
 - ii. the amalgamated or reconstructed entity has the financial standing to perform its obligations under this Agreement and has a credit worthiness at least as good as that of the Contractor as at the Appointed Date;
- (n) any representation or warranty of the Contractor herein contained which is, as of the date hereof, found to be false or the Contractor is at any time hereafter found to be in breach or non-compliance thereof;
- (o) the Contractor submits to the Authority any statement, notice or other document, in written or electronic form, which has a material effect on the Authority's rights, obligations or interests and which is false in material particulars;
- (p) the Contractor has failed to fulfil any obligation, for which failure Termination has been specified in this Agreement; or
- (q) the Contractor commits a default in complying with any other provision of this Agreement if such a default causes a Material Adverse Effect on the Project or on the Authority.
- (r) gives or offers to give (directly or indirectly) to any person any bribe, gift, gratuity, commission or other thing of value, as an inducement or reward:
 - i. for doing or forbearing to do any action in relation to the Contract, or

- ii. for showing or forbearing to show favour or disfavour to any person in relation to the Contract,

or if any of the Contractor's personnel, agents or subcontractors gives or offers to give (directly or indirectly) to any person any such inducement or reward as is described in this sub-paragraph (s). However, lawful inducements and rewards to Contractor's Personnel shall not entitle termination.
- (ii) Without prejudice to any other rights or remedies which the Authority may have under this Agreement, upon occurrence of a Contractor Default, the Authority shall be entitled to terminate this Agreement by issuing a Termination Notice to the Contractor; provided that before issuing the Termination Notice, the Authority shall by a notice inform the Contractor of its intention to issue such Termination Notice and grant 15 (fifteen) days to the Contractor to make a representation, and may after the expiry of such 15 (fifteen) days, whether or not it is in receipt of such representation, issue the Termination Notice.
- (iii) The following shall apply in respect of cure of any of the defaults and/ or breaches of the Agreement:
 - (a) The Cure Period shall commence from the date of the notice by the Authority to the Contractor asking the latter to cure the breach or default specified in such notice;
 - (b) The Cure Period provided in the Agreement shall not relieve the Contractor from liability for Damages caused by its breach or default;
 - (c) The Cure Period shall not in any way be extended by any period of suspension under the Agreement;
 - (d) If the cure of any breach by the Contractor requires any reasonable action by the Contractor that must be approved by the Authority hereunder the applicable Cure Period (and any liability of the Contractor for damages incurred) shall be extended by the period taken by the Authority to accord its required approval.
- (iv) After termination of this Agreement for Contractor Default, the Authority may complete the Works and/or arrange for any other entities to do so. The Authority and these entities may then use any Materials, Plant and equipment, Contractor's documents and other design documents made by or on behalf of the Contractor.

23.2. Termination for Authority Default

- (i) In the event that any of the defaults specified below shall have occurred, and the Authority fails to cure such default within a Cure Period of 90 (ninety) days or such longer period as has been expressly provided in this Agreement, the Authority shall be deemed to be in default of this Agreement (the "**Authority Default**") unless the default has occurred as a result of any breach of this Agreement by the Contractor or due to Force Majeure. The defaults referred to herein shall include:

- (a) the Authority commits a material default in complying with any of the provisions of this Agreement and such default has a Material Adverse Effect on the Contractor;
 - (b) the Authority has failed to make payment of any amount due and payable to the Contractor within the period specified in this Agreement;
 - (c) the Authority has failed to provide, within a period of 180 (one hundred and eighty) days from the Appointed Date, the environmental clearances required for construction of the Project Highway;
 - (d) the Authority becomes bankrupt or insolvent, goes into liquidation, has a receiving or administration order made against him, compounds with its creditors, or carries on business under a receiver, trustee or manager for the benefit of its creditors, or if any act is done or event occurs which (under Applicable Laws) has a similar effect;
 - (e) the Authority repudiates this Agreement or otherwise takes any action that amounts to or manifests an irrevocable intention not to be bound by this Agreement;
 - (f) the Authority's Engineer fails to issue the relevant Interim Payment Certificate within 60 (sixty) days after receiving a statement and supporting documents; or
 - (g) the whole work is suspended by Authority beyond 120 (one hundred twenty) days for any reason which is not attributed to the Contractor.
- (ii) Without prejudice to any other right or remedy which the Contractor may have under this Agreement, upon occurrence of an Authority Default, the Contractor shall be entitled to terminate this Agreement by issuing a Termination Notice to the Authority; provided that before issuing the Termination Notice, the Contractor shall by a notice inform the Authority of its intention to issue the Termination Notice and grant 15 (fifteen) days to the Authority to make a representation, and may after the expiry of such 15 (fifteen) days, whether or not it is in receipt of such representation, issue the Termination Notice.
- If on the consideration of the Authority's representation or otherwise, the contractor does not issue the Termination Notice on such 15th (fifteenth) day and prefers to continue with the project, it is deemed that the cause of action of the Termination Notice has been condoned by the Contractor and he would be deemed to have waived any claim and forfeited any right to any other remedy on that count or in relation to such action or omission.

23.3. Termination for Authority's convenience

Notwithstanding anything stated hereinabove, the Authority may terminate this Agreement for convenience. The termination shall take effect 30 (thirty) days from the date of notice provided to the Contractor.

23.4. Requirements after Termination

Upon Termination of this Agreement in accordance with the terms of this Article 23, the Contractor shall comply with and conform to the following:

- (a) deliver all relevant records, reports, Intellectual Property and other licences pertaining to the Works, Maintenance, other design documents;
- (b) transfer and/or deliver all Applicable Permits to the extent permissible under Applicable Laws; and
- (c) vacate the Site within 15 (fifteen) days.

23.5. Valuation of Unpaid Works

- (i) Within a period of 45 (forty-five) days after Termination under Clause 23.1, 23.2 or 23.3, as the case may be, has taken effect, the Authority's Engineer shall proceed in accordance with Clause 18.5 to determine as follows the valuation of unpaid Works (the "**Valuation of Unpaid Works**"):
 - (a) value of the completed stage of the Works, less payments already made;
 - (b) reasonable value of the partially completed stages of works as on the date of Termination, only if such works conform with the Specifications and Standards; and
 - (c) value of Maintenance, if any, for completed months, less payments already made, and shall adjust from the sum thereof (i) any other amounts payable or recoverable, as the case may be, in accordance with the provisions of this Agreement; and (ii) all taxes due to be deducted at source.
- (ii) The Valuation of Unpaid Works shall be communicated to the Authority, with a copy to the Contractor, within a period of 30 (thirty) days from the date of Termination.

23.6. Termination Payment

- (i) Upon Termination on account of Contractor's Default under Clause 23.1, the Authority shall:
 - (a) encash and appropriate the Performance Security, Additional Performance Security if any and Retention Money, or in the event the Contractor has failed to replenish or extend the Performance Security and Additional Performance Security if any, claim the amount stipulated in Clause 7.1, as agreed pre determined compensation to the Authority for any losses, delays and cost of completing the Works and Maintenance, if any;
 - (b) encash and appropriate the Bank Guarantee, if any, for and in respect of the outstanding Advance Payment and interest thereon; and

- (c) pay to the Contractor, by way of Termination Payment, an amount equivalent to the Valuation of Unpaid Works after adjusting any other sums payable or recoverable, as the case may be, in accordance with the provisions of this Agreement.
- (ii) Upon Termination on account of an Authority Default under Clause 23.2 or for Authority's convenience under Clause 23.3, the Authority shall:
- (a) return the Performance Security, Additional Performance Security and Retention Money forthwith;
 - (b) encash and appropriate the bank guarantee, if any, for and in respect of the outstanding Advance Payment; and pay to the Contractor, by way of Termination Payment, an amount equal to:
 - (c) pay to the Contractor, by way of Termination Payment, an amount equal to:
 - i. Valuation of Unpaid Works;
 - ii. the reasonable cost of temporary works, as determined by the Authority's Engineer; and
 - iii. 10% (ten per cent) of the cost of the Works and Maintenance that are not commenced or not completed,

and shall adjust from the sum thereof (i) any other amounts payable or recoverable, as the case may be, in accordance with the provisions of this Agreement, and (ii) all taxes due to be deducted at source.
- (iii) Termination Payment shall become due and payable to the Contractor within 30 (thirty) days of a demand being made by the Contractor to the Authority with the necessary particulars, and in the event of any delay, the Authority shall pay interest at 9% (nine per cent) per annum, on the amount of Termination Payment remaining unpaid; provided that such delay shall not exceed 90 (ninety) days. For the avoidance of doubt, it is expressly agreed that Termination Payment shall constitute full discharge by the Authority of its payment obligations in respect thereof hereunder.
- (iv) The Contractor expressly agrees that Termination Payment under this Article 23 shall constitute a full and final settlement of all claims of the Contractor on account of Termination of this Agreement and that it shall not have any further right or claim under any law, treaty, convention, contract or otherwise.

23.7. Other rights and obligations of the Parties

Upon Termination for any reason whatsoever:

- (a) property and ownership in all Materials, Plant and Works and the Project Highway shall, as between the Contractor and the Authority, vest in the Authority in whole; provided that the foregoing shall be without prejudice to

Clause 23.6;

- (b) risk of loss or damage to any Materials, Plant or Works and the care and custody thereof shall pass from the Contractor to the Authority; and
- (c) the Authority shall be entitled to restrain the Contractor and any person claiming through or under the Agreement from entering upon the Site or any part of the Project, which have not been vested in the Authority in accordance with the provisions of this Agreement.

23.8. Survival of rights

Notwithstanding anything to the contrary contained in this Agreement any Termination pursuant to the provisions of this Agreement shall be without prejudice to the accrued rights of either Party including its right to claim and recover money damages, insurance proceeds, security deposits, and other rights and remedies, which it may have in law or Agreement. All rights and obligations of either Party under this Agreement, including Termination Payments, shall survive the Termination to the extent such survival is necessary for giving effect to such rights and obligations.

23.9. Foreclosure with mutual consent

- (i) Without prejudice to any provision of this Agreement, the Authority and Contractor may foreclose this Agreement by mutual consent in circumstances which does not constitute either party's default without any liability or consequential future liability for either party.
- (ii) Should a Party intend to foreclose this Agreement by mutual consent, the intending Party shall issue a notice to the other Party and upon issuance of such notice, the other Party may within 15 days from receipt of such notice either agree to such foreclosure or raise objection(s) to the same by intimating either of the two possible positions to the intending Party in writing.
- (iii) In either case of the other Party agreeing to the proposed foreclosure or otherwise, the Parties may negotiate the proposed foreclosure and sign a Supplementary Agreement for foreclosure to the main Contract Agreement within 30 (thirty) days of the date agreeing by both Parties. Foreclosure shall not come into effect unless and otherwise Supplementary Agreement is signed.
- (iv) Any attempt or endeavor for foreclosure by mutual agreement shall be without prejudice to the rights and obligations of the Parties herein and the factum of such an attempt or exercise shall not stop either of the Parties from discharging their contractual obligations under this Agreement.
- (v) For the avoidance of doubt, it is clarified that such foreclosure will be without prejudice to the Contractor and shall not affect the Contractor in any way if it wishes to bid in future projects of the Authority.

Part VI
Other Provisions

Article 24

Assignment and Charges

24.1. Restrictions on assignment and charges

This Agreement shall not be assigned by the Contractor to any person, save and except with the prior consent in writing of the Authority, which consent the Authority shall be entitled to decline without assigning any reason.

24.2. Hypothecation of Materials or Plant

Notwithstanding the provisions of Clause 24.1, the Contractor may pledge or hypothecate to its lenders, any Materials or Plant prior to their incorporation in the Works. Further, the Contractor may, by written notice to the Authority, assign its right to receive payments under this Agreement either absolutely or by way of charge, to any person providing financing to the Contractor in connection with the performance of the Contractor's obligations under this Agreement. The Contractor acknowledges that any such assignment by the Contractor shall not relieve the Contractor from any obligations, duty or responsibility under this Agreement.

Article 25

Liability and Indemnity

25.1. General indemnity

- (i) The Contractor will indemnify, defend, save and hold harmless the Authority and its officers, servants, agents, Government Instrumentalities and Government owned and/or controlled entities/enterprises, (the "**Authority Indemnified Persons**") against any and all suits, proceedings, actions, demands and third party claims for any loss, damage, cost and expense of whatever kind and nature, whether arising out of any breach by the Contractor of any of its obligations under this Agreement or from any negligence under the Agreement, including any errors or deficiencies in the design documents, or tort or on any other ground whatsoever, except to the extent that any such suits, proceedings, actions, demands and claims have arisen due to any negligent act or omission, or breach or default of this Agreement on the part of the Authority Indemnified Persons.

25.2. Indemnity by the Contractor

- (i) Without limiting the generality of Clause 25.1, the Contractor shall fully indemnify, hold harmless and defend the Authority and the Authority Indemnified Persons from and against any and all loss and/or damages arising out of or with respect to:
- (a) failure of the Contractor to comply with Applicable Laws and Applicable Permits;
 - (b) payment of taxes required to be made by the Contractor in respect of the income or other taxes of the Sub-contractors, suppliers and representatives; or
 - (c) non-payment of amounts due because of Materials or services furnished to the Contractor or any of its Sub-contractors which are payable by the Contractor or any of its Sub-contractors.
- (ii) Without limiting the generality of the provisions of this Article 25, the Contractor shall fully indemnify, hold harmless and defend the Authority Indemnified Persons from and against any and all suits, proceedings, actions, claims, demands, liabilities and damages which the Authority Indemnified Persons may hereafter suffer, or pay by reason of any demands, claims, suits or proceedings arising out of claims of infringement of any domestic or foreign patent rights, copyrights or other intellectual property, proprietary or confidentiality rights with respect to any materials, information, design or process used by the Contractor or by the Sub-contractors in performing the Contractor's obligations or in any way incorporated in or related to the Project. If in any such suit, action, claim or proceedings, a temporary restraint order or preliminary injunction is granted, the Contractor shall make every reasonable effort, by giving a satisfactory bond or otherwise, to secure the revocation or suspension of the injunction or restraint order. If, in any such suit, action, claim or proceedings, the Project Highway, or any part thereof or comprised therein, is held to constitute an

infringement and its use is permanently enjoined, the Contractor shall promptly make every reasonable effort to secure for the Authority a licence, at no cost to the Authority, authorising continued use of the infringing work. If the Contractor is unable to secure such licence within a reasonable time, the Contractor shall, at its own expense, and without impairing the Specifications and Standards, either replace the affected work, or part, or process thereof with non-infringing work or part or process or modify the same so that it becomes non-infringing.

25.3. Notice and contest of claims

In the event that either Party receives a claim or demand from a third party in respect of which it is entitled to the benefit of an indemnity under this Article 25 (the "**Indemnified Party**") it shall notify the other Party (the "**Indemnifying Party**") within 15 (fifteen) days of receipt of the claim or demand and shall not settle or pay the claim without the prior approval of the Indemnifying Party, which approval shall not be unreasonably withheld or delayed. If the Indemnifying Party wishes to contest or dispute the claim or demand, it may conduct the proceedings in the name of the Indemnified Party, subject to the Indemnified Party being secured against any costs involved, to its reasonable satisfaction.

25.4. Defence of claims

- (i) The Indemnified Party shall have the right, but not the obligation, to contest, defend and litigate any claim, action, suit or proceeding by any third party alleged or asserted against such Party in respect of, resulting from, related to or arising out of any matter for which it is entitled to be indemnified hereunder, and reasonable costs and expenses thereof shall be indemnified by the Indemnifying Party. If the Indemnifying Party acknowledges in writing its obligation to indemnify the Indemnified Party in respect of loss to the full extent provided by this Article 25, the Indemnifying Party shall be entitled, at its option, to assume and control the defence of such claim, action, suit or proceeding, liabilities, payments and obligations at its expense and through the counsel of its choice; provided it gives prompt notice of its intention to do so to the Indemnified Party and reimburses the Indemnified Party for the reasonable cost and expenses incurred by the Indemnified Party prior to the assumption by the Indemnifying Party of such defence. The Indemnifying Party shall not be entitled to settle or compromise any claim, demand, action, suit or proceeding without the prior written consent of the Indemnified Party, unless the Indemnifying Party provides such security to the Indemnified Party as shall be reasonably required by the Indemnified Party to secure the loss to be indemnified hereunder to the extent so compromised or settled.
- (ii) If the Indemnifying Party has exercised its rights under Clause 25.3, the Indemnified Party shall not be entitled to settle or compromise any claim, action, suit or proceeding without the prior written consent of the Indemnifying Party (which consent shall not be unreasonably withheld or delayed).
- (iii) If the Indemnifying Party exercises its rights under Clause 25.3, the Indemnified Party shall nevertheless have the right to employ its own counsel, and such counsel may participate in such action, but the fees and expenses of such counsel shall be at the

expense of the Indemnified Party, when and as incurred, unless:

- (a) the employment of counsel by such party has been authorised in writing by the Indemnifying Party; or
- (b) the Indemnified Party shall have reasonably concluded that there may be a conflict of interest between the Indemnifying Party and the Indemnified Party in the conduct of the defence of such action; or
- (c) the Indemnifying Party shall not, in fact, have employed independent counsel reasonably satisfactory to the Indemnified Party, to assume the defence of such action and shall have been so notified by the Indemnified Party; or
- (d) the Indemnified Party shall have reasonably concluded and specifically notified the Indemnifying Party either:
 - i. that there may be specific defences available to it which are different from or additional to those available to the Indemnifying Party; or
 - ii. that such claim, action, suit or proceeding involves or could have a material adverse effect upon it beyond the scope of this Agreement:

Provided that if Sub-clauses (b), (c) or (d) of this Clause 25.4 (iii) shall be applicable, the counsel for the Indemnified Party shall have the right to direct the defence of such claim, demand, action, suit or proceeding on behalf of the Indemnified Party, and the reasonable fees and disbursements of such counsel shall constitute legal or other expenses hereunder.

25.5. Survival on Termination

The provisions of this Article 25 shall survive Termination.

Article 26

Dispute Resolution

26.1 Dispute Resolution

- (i) Any dispute, difference or controversy of whatever nature howsoever arising under or out of or in relation to this Agreement (including its interpretation) between the Parties, and so notified in writing by either Party to the other Party (the "**Dispute**") shall, in the first instance, be attempted to be resolved amicably in accordance with the conciliation procedure set forth in Clause 26.2.
- (ii) The Parties agree to use their best efforts for resolving all Disputes arising under or in respect of this Agreement promptly, equitably and in good faith, and further agree to provide each other with reasonable access during normal business hours to all non-privileged records, information and data pertaining to any Dispute.

26.2 Conciliation

In the event of any Dispute between the Parties, either Party may call upon the Authority's Engineer, or such other person as the Parties may mutually agree upon (the "**Conciliator**") to mediate and assist the Parties in arriving at an amicable settlement thereof. Failing mediation by the Conciliator or without the intervention of the Conciliator, either Party may require such Dispute to be referred to the Chairman of the Authority and the Chairman of the Board of Directors of the Contractor for amicable settlement, and upon such reference, the said persons shall meet no later than 7 (seven) business days from the date of reference to discuss and attempt to amicably resolve the Dispute. If such meeting does not take place within the 7 (seven) business day period or the Dispute is not amicably settled within 15 (fifteen) days of the meeting or the Dispute is not resolved as evidenced by the signing of written terms of settlement within 30 (thirty) days of the notice in writing referred to in Clause 26.1.1 or such longer period as may be mutually agreed by the Parties, either Party may refer the Dispute to arbitration in accordance with the provisions of Clause 26.3 but before resorting to such arbitration, the parties agree to explore conciliation by the Conciliation Committees of Independent Experts set up by the Authority in accordance with the procedure decided by the panel of such experts and notified by the Authority on its website including its subsequent amendments. In the event of the conciliation proceedings being successful, the parties to the dispute would sign the written settlement agreement and the conciliators would authenticate the same. Such settlement agreement would then be binding on the parties in terms of Section 73 of the Arbitration Act. In case of failure of the conciliation process even at the level of the Conciliation Committee, either party may refer the Dispute to arbitration in accordance with the provisions of Clause 26.3.

26.3 Arbitration

- (i) Any Dispute which is not resolved amicably by conciliation, as provided in Clause 26.2, shall be finally settled by arbitration in accordance with the rules of arbitration of the Society for Affordable Redressal of Disputes (SAROD).

- (ii) The parties expressly agree as under in case of arbitration of disputes:
- (a) There shall be no arbitration for a dispute involving a claim value upto INR 50 Lakh (INR fifty lakh). The Authority's Engineer shall give a reasoned decision in case of such dispute and the same shall be binding on both the parties.
 - (b) In case of a dispute involving claim value of above INR 50 Lakh (INR fifty lakh), but upto INR 50 Crore (INR fifty crore), the same shall be referred to a Sole Arbitrator. Authority shall within 30 (thirty) days propose names of 5 (five) Arbitrators from the list of Arbitrators maintained by SAROD (Society for Affordable Redressal of Disputes) and the Contractor shall within 30 (thirty) days select one name from the list of five and the name so selected by the Contractor shall be the Sole Arbitrator for the matter in dispute. In case Authority delays in providing the list of 5 (five) names, President, SAROD will provide 5 names within 30 (thirty) days of receipt of reference from aggrieved party in this regard. In case the Contractor fails in selecting one from the list of five, President, SAROD shall select one from the list of five provided by Authority within 30 (thirty) days of receipt of reference from aggrieved party in this regard.
 - (c) In case of a dispute involving a claim value of more than INR 50 Crore (INR fifty crore), the same shall be referred to an Arbitral Tribunal comprising 3 (three) Arbitrators. The Dispute shall be settled in accordance with the rules of Arbitration of the Society for Affordable Redressal of Disputes (SAROD).
 - (d) The venue of arbitration shall be Delhi, and the language of arbitration proceedings shall be English.
 - (e) The fees of the Arbitrators shall be as per the rates fixed by the Authority from time to time. The cost of arbitration shall be shared equally by the parties.
 - (f) Neither Party shall be entitled for any pre-reference or pendent lite interest, i.e., interest from date of cause of action till date of Award by Arbitral Tribunal. The parties specifically agree that claim for any such interest shall not be considered and shall be void. The Arbitrator or Arbitral Tribunal shall have no power/ jurisdiction to award pre-reference or pendent lite interest in case of disputes.
- (iii) The Arbitrators shall make a reasoned award (the "Award"). Any Award made in any arbitration held pursuant to this Article 26 shall be final and binding on the Parties as from the date it is made, and the Contractor and the Authority agree and undertake to carry out such Award without delay.
- (iv) The Contractor and the Authority agree that an Award may be enforced against the Contractor and/or the Authority, as the case may be, and their respective assets wherever situated.
- (v) This Agreement and the rights and obligations of the Parties shall remain in full force and effect, pending the Award in any arbitration proceedings hereunder. Further, the parties

unconditionally acknowledge and agree that notwithstanding any dispute between them, each Party shall proceed with the performance of its respective obligations, pending resolution of Dispute in accordance with this Article.

- (vi) In the event the Party against whom the Award has been granted challenges the Award for any reason in a court of law, it shall make an interim payment to the other Party for an amount equal to 75% (seventy five per cent) of the Award, pending final settlement of the Dispute. The aforesaid amount shall be paid forthwith upon furnishing an irrevocable Bank Guarantee for a sum equal to 120 % (one hundred and twenty per cent) of the aforesaid amount. Upon final settlement of the Dispute, the aforesaid interim payment shall be adjusted and any balance amount due to be paid or returned, as the case may be, shall be paid or returned with interest calculated at the rate of 10% (ten per cent) per annum from the date of interim payment to the date of final settlement of such balance.

26.4 Adjudication by Regulatory Authority, Tribunal or Commission

In the event of constitution of a statutory regulatory authority, tribunal or commission, as the case may be, with powers to adjudicate upon disputes between the Contractor and the Authority, all Disputes arising after such constitution shall, instead of reference to arbitration under Clause 26.3, be adjudicated upon by such regulatory authority, tribunal or commission in accordance with the Applicable Law and all references to Dispute Resolution Procedure shall be construed accordingly. For the avoidance of doubt, the Parties hereto agree that the adjudication hereunder shall not be final and binding until an appeal against such adjudication has been decided by an appellate tribunal or court of competent jurisdiction, as the case may be, or no such appeal has been preferred within the time specified in the Applicable Law.

Article 27

Miscellaneous

27.1. Governing law and jurisdiction

This Agreement shall be construed and interpreted in accordance with and governed by the laws of India, and the courts at [Delhi] shall have exclusive jurisdiction over matters arising out of or relating to this Agreement.

27.2. Waiver of immunity

Each Party unconditionally and irrevocably:

- (a) agrees that the execution, delivery and performance by it of this Agreement constitute commercial acts done and performed for commercial purpose;
- (b) agrees that, should any proceedings be brought against it or its assets, property or revenues in any jurisdiction in relation to this Agreement or any transaction contemplated by this Agreement, no immunity (whether by reason of sovereignty or otherwise) from such proceedings shall be claimed by or on behalf of the Party with respect to its assets;
- (c) waives any right of immunity which it or its assets, property or revenues now has, may acquire in the future or which may be attributed to it in any jurisdiction; and
- (d) consents generally in respect of the enforcement of any judgement or award against it in any such proceedings to the giving of any relief or the issue of any process in any jurisdiction in connection with such proceedings (including the making, enforcement or execution against it or in respect of any assets, property or revenues whatsoever irrespective of their use or intended use of any order or judgement that may be made or given in connection therewith).

27.3. Delayed payments

The Parties hereto agree that payments due from one Party to the other Party under the provisions of this Agreement shall be made within the period set forth therein, and if no such period is specified, within 30 (thirty) days of receiving a demand along with the necessary particulars. In the event of delay beyond such period, the defaulting Party shall pay interest for the period of delay calculated at a rate equal to Base Rate plus 2 (two) percent, calculated at quarterly rests, and recovery thereof shall be without prejudice to the rights of the Parties under this Agreement including Termination thereof.

27.4. Waiver

- (i) Waiver, including partial or conditional waiver, by either Party of any default by the other Party in the observance and performance of any provision of or obligations under this Agreement:-
 - (a) shall not operate or be construed as a waiver of any other or subsequent default hereof or of other provisions of or obligations under this Agreement;

- (b) shall not be effective unless it is in writing and executed by a duly authorized representative of the Party; and
 - (c) shall not affect the validity or enforceability of this Agreement in any manner.
- (ii) Neither the failure by either Party to insist on any occasion upon the performance of the terms, conditions and provisions of this Agreement or any obligation thereunder nor time or other indulgence granted by a Party to the other Party shall be treated or deemed as waiver of such breach or acceptance of any variation or the relinquishment of any such right hereunder.

27.5. Liability for review of Documents and Drawings

Except to the extent expressly provided in this Agreement:

- (a) no review, comment or approval by the Authority or the Authority's Engineer of any Document or Drawing submitted by the Contractor nor any observation or inspection of the construction, or maintenance of the Project Highway nor the failure to review, approve, comment, observe or inspect hereunder shall relieve or absolve the Contractor from its obligations, duties and liabilities under this Agreement, the Applicable Laws and Applicable Permits; and
- (b) the Authority shall not be liable to the Contractor by reason of any review, comment, approval, observation or inspection referred to in Sub-clause (a) above.

27.6. Exclusion of implied warranties etc.

This Agreement expressly excludes any warranty, condition or other undertaking implied at law or by custom or otherwise arising out of any other agreement between the Parties or any representation by either Party not contained in a binding legal agreement executed by both Parties.

27.7. Survival

- (i) Termination shall:
 - (a) not relieve the Contractor or the Authority, as the case may be, of any obligations hereunder which expressly or by implication survive Termination hereof; and
 - (b) except as otherwise provided in any provision of this Agreement expressly limiting the liability of either Party, not relieve either Party of any obligations or liabilities for loss or damage to the other Party arising out of, or caused by, acts or omissions of such Party prior to the effectiveness of such Termination or arising out of such Termination.
- (ii) All obligations surviving Termination shall only survive for a period of 3 (three) years following the date of such Termination.

27.8. Entire Agreement

This Agreement and the Schedules together constitute a complete and exclusive statement of the terms of the agreement between the Parties on the subject hereof, and no amendment or modification hereto shall be valid and effective unless such

modification or amendment is agreed to in writing by the Parties and duly executed by persons especially empowered in this behalf by the respective Parties. All prior written or oral understandings, offers or other communications of every kind pertaining to this Agreement are abrogated and withdrawn. For the avoidance of doubt, the Parties hereto agree that any obligations of the Contractor arising from the Request for Qualification or Request for Proposals, as the case may be, shall be deemed to form part of this Agreement and treated as such.

27.9. Severability

If for any reason whatever, any provision of this Agreement is or becomes invalid, illegal or unenforceable or is declared by any court of competent jurisdiction or any other instrumentality to be invalid, illegal or unenforceable, the validity, legality or enforceability of the remaining provisions shall not be affected in any manner, and the Parties will negotiate in good faith with a view to agreeing to one or more provisions which may be substituted for such invalid, unenforceable or illegal provisions, as nearly as is practicable to such invalid, illegal or unenforceable provision. Failure to agree upon any such provisions shall not be subject to the Dispute Resolution Procedure set forth under this Agreement or otherwise.

27.10. No partnership

This Agreement shall not be interpreted or construed to create an association, joint venture or partnership between the Parties, or to impose any partnership obligation or liability upon either Party, and neither Party shall have any right, power or authority to enter into any agreement or undertaking for, or act on behalf of, or to act as or be an agent or representative of, or to otherwise bind, the other Party.

27.11. Third parties

This Agreement is intended solely for the benefit of the Parties and their respective successors and permitted assigns, and nothing in this Agreement shall be construed to create any duty to, standard of care with reference to, or any liability to, any person not a Party to this Agreement.

27.12. Successors and assigns

This Agreement shall be binding upon, and inure to the benefit of the Parties and their respective successors and permitted assigns.

27.13. Notices

Any notice or other communication to be given by any Party to the other Party under or in connection with the matters contemplated by this Agreement shall be in writing and shall:

- (a) in the case of the Contractor, be given by facsimile or e-mail and by letter delivered by hand to the address given and marked for attention of the person set out below or to such other person as the Contractor may from time to time designate by notice to the Authority; provided that notices or other communications to be given to an address outside [Delhi] may, if they are subsequently confirmed by sending a copy thereof by registered

acknowledgement due, air mail or by courier, be sent by facsimile or e-mail to the person as the Contractor may from time to time designate by notice to the Authority; [***]

- (b) in the case of the Authority, be given by facsimile or e-mail and by letter delivered by hand and be addressed to the [Chairman] of the Authority with a copy delivered to the Authority Representative or such other person as the Authority may from time to time designate by notice to the Contractor; provided that if the Contractor does not have an office in [Delhi] it may send such notice by facsimile or e-mail and by registered acknowledgement due, air mail or by courier; and
- (c) any notice or communication by a Party to the other Party, given in accordance herewith, shall be deemed to have been delivered when in the normal course of post it ought to have been delivered and in all other cases, it shall be deemed to have been delivered on the actual date and time of delivery; provided that in the case of facsimile or e-mail, it shall be deemed to have been delivered on the working day following the date of its delivery.

27.14. Language

All notices required to be given by one Party to the other Party and all other communications, Documentation and proceedings which are in any way relevant to this Agreement shall be in writing and in English language.

27.15. Counterparts

This Agreement may be executed in two counterparts, each of which, when executed and delivered, shall constitute an original of this Agreement.

27.16. Confidentiality

The Parties shall treat the details of this Agreement as private and confidential, except to the extent necessary to carry out obligations under it or to comply with Applicable Laws. The Contractor shall not publish, permit to be published, or disclose any particulars of the Works in any trade or technical paper or elsewhere without the previous agreement of the Authority.

27.17. Copyright and Intellectual Property rights

- (i) As between the Parties, the Contractor shall retain the copyright and other Intellectual Property rights in the Contractor's documents and other design documents made by (or on behalf of) the Contractor. The Contractor shall be deemed (by signing this Agreement) to give to the Authority a non-terminable transferable non-exclusive royalty-free licence to copy, use and communicate the Contractor's documents, including making and using modifications of them. This licence shall:
 - (a) apply throughout the actual or intended working life (whichever is longer) of the relevant parts of the Works;
 - (b) entitle any person in proper possession of the relevant part of the Works to copy, use and communicate the Contractor's documents for the purposes of

completing, operating, maintaining, altering, adjusting, repairing and demolishing the Works; and

- (c) in the case of Contractor's documents which are in the form of computer programs and other software, permit their use on any computer on the Site and other places as envisaged by this Agreement, including replacements of any computers supplied by the Contractor.
- (ii) The Contractor's documents and other design documents made by (or on behalf of) the Contractor shall not, without the Contractor's consent, be used, copied or communicated to a third party by (or on behalf of) the Authority for purposes other than those permitted under this Clause 27.17.
- (iii) As between the Parties, the Authority shall retain the copyright and other intellectual property rights in this Agreement and other documents made by (or on behalf of) the Authority. The Contractor may, at its cost, copy, use, and obtain communication of these documents for the purposes of this Agreement. They shall not, without the Authority's consent, be copied, used or communicated to a third party by the Contractor, except as necessary for the purposes of the contract.

27.18. Limitation of Liability

- (i) Neither Party shall be liable to the other Party for loss of use of any Works, loss of profit, loss of any contract or for any indirect or consequential loss or damage which may be suffered by the other Party in connection with this Agreement, save and except as provided under Articles 23 and 25.
- (ii) The total liability of one Party to the other Party under and in accordance with the provisions of this Agreement, save and except as provided in Articles 23 and 25, shall not exceed the Contract Price. For the avoidance of doubt, this Clause shall not limit the liability in any case of fraud, deliberate default or reckless misconduct by the defaulting Party.

27.19. Care and Supply of Documents

- (i) Each of the Contractor's documents shall be in the custody and care of the Contractor, unless and until taken over by the Authority. Unless otherwise stated in the Agreement, the Contractor shall supply to the Authority 2 (two) copies of the each of the Contractor's documents.
- (ii) The Contractor shall keep, on the Site, a copy of the Agreement, publication named in the Authority's requirements, the Contractor's documents, and variations and other communications given under the Agreement. The Authority's personnel shall have the right of access to all these documents at all reasonable times.
- (iii) If a Party becomes aware of an error or defect of a technical nature in a document which was prepared for use in executing the Works, the Party shall promptly give notice to the other party of such error or defect.

27.20. Authority's Use of Contractor's Documents.

- (i) As between the Parties, the Contractor shall retain the copyright and other

Intellectual Property rights in the Contractor's Documents and other design documents made by (or on behalf of) the Contractor.

- (ii) The Contractor hereby gives to the Authority a non-terminable transferable nonexclusive royalty-free license to copy, use and communicate the Contractor's Documents, including making and using modifications of them. This license shall:
 - (a) apply throughout the actual or intended working life (whichever is longer) of the relevant parts of the Works,
 - (b) entitle any person in proper possession of the relevant part of the Works to copy, use and communicate the Contractor's Documents for the purposes of completing, operating, maintaining, altering, adjusting, repairing and demolishing the Works, and
 - (c) in the case of Contractor's Documents which are in the form of computer programs and other software, permit their use on any computer on the Site and other places as envisaged by the Contractor, including replacements of any computers supplied by the Contractor.
- (iii) The Contractor's Documents and other design documents made by or on behalf of the Contractor shall not, without the Contractor's consent, be used, copied or communicated to a third party by (or on behalf of) the Authority for purposes other than those permitted under this Sub-Clause.

27.21. Contractor's Use of Authority's Documents

As between the Parties, the Authority shall retain the copyright and other intellectual property rights in the Authority's requirements and other Documents made by (or on behalf of) the Authority. The Contractor may, at its cost copy, use, and obtain communication of these documents for the purpose of the Agreement. They shall not without the Authority's consent, be copied, used or communicating to a third party by the Contractor, except as necessary for the purposes of the Agreement.

27.22. Access to the Site by Others

The Contractor shall, at all times, afford access to the Site to the authorized representatives of the Authority, the Authority's Engineer and anyone else authorized by the Authority to access the site and to the persons duly authorized by any Governmental Agency having jurisdiction over the Project, including those concerned with safety, security or environmental protection to inspect the Project Highway and to investigate any matter within their authority and upon reasonable notice, the Contractor shall provide to such persons reasonable assistance necessary to carry out their respective duties and functions with minimum disruption to the construction, operation and maintenance of the Project Highway consistent with the purpose for which such persons have gained such access to the Site.

27.23. Term

This Agreement shall come into force and effect from the date first hereinabove written and shall remain in force and effect till the Termination Date i.e. the Parties perform all their respective obligations or is terminated by any of the Parties for the reasons and in the manner provided for in the Agreement.

27.24. Amendments

The Agreement may not be supplemented, amended, modified or changed except by an instrument in writing signed by the Contractor and the Authority and expressed to be a supplement, modification or change to the Agreement.

27.25. Representation and Bribes

The Contractor represents and warrants to the Authority that:

- (a) No representation or warranty by the Contractor contained herein or in any other document furnished by it to the Authority, or to any Governmental Instrumentality in relation to Applicable Permits contains or will contain any untrue statement of material fact or omits or will omit to state a material fact necessary to make such representation or warranty not misleading; and
- (b) It warrants that no sums, in cash or kind, have been paid or will be paid by or on behalf of the Contractor, to any person by way of fees, commission or otherwise for securing or entering into the Contractor for influencing or attempting to influence any officer or employee of the Authority or GOI in connection therewith.

27.26. No Agency

The Agreement does not constitute either Party as the agent, partner or legal representative of the other for any purposes whatsoever, and neither Party shall have any express or implied right or authority to assume or to create any obligation or responsibility on behalf of or in the name of the other Party.

Schedules

Schedule-A

(See Clauses 2.1 and 8.1)

Site of the Project

1. The Site

- (i) Site of the [Two-Lane] Project Highway shall include the land, buildings, structures and road works as described in Annex-I of this Schedule-A.
- (ii) The dates of handing over the Right of Way to the Contractor are specified in Annex-II of this Schedule-A.
- (iii) An inventory of the Site including the land, buildings, structures, road works, trees and any other immovable property on, or attached to, the Site shall be prepared jointly by the Authority Representative and the Contractor, and such inventory shall form part of the memorandum referred to in Clause 8.2 (i) of this Agreement.
- (iv) The alignment plans of the Project Highway are specified in Annex-III. In the case of sections where no modification in the existing alignment of the Project Highway is contemplated, the alignment plan has not been provided. Alignment plans have only been given for sections where the existing alignment is proposed to be upgraded. The proposed profile of the Project Highways shall be followed by the contractor with minimum FRL as indicated in the alignment plan. The Contractor, however, improve/upgrade the Road Profile as indicated in Annex-III based on site/design requirement.
- (v) The status of the environment clearances obtained or awaited is given in Annex-IV.



Project Location Map on Google

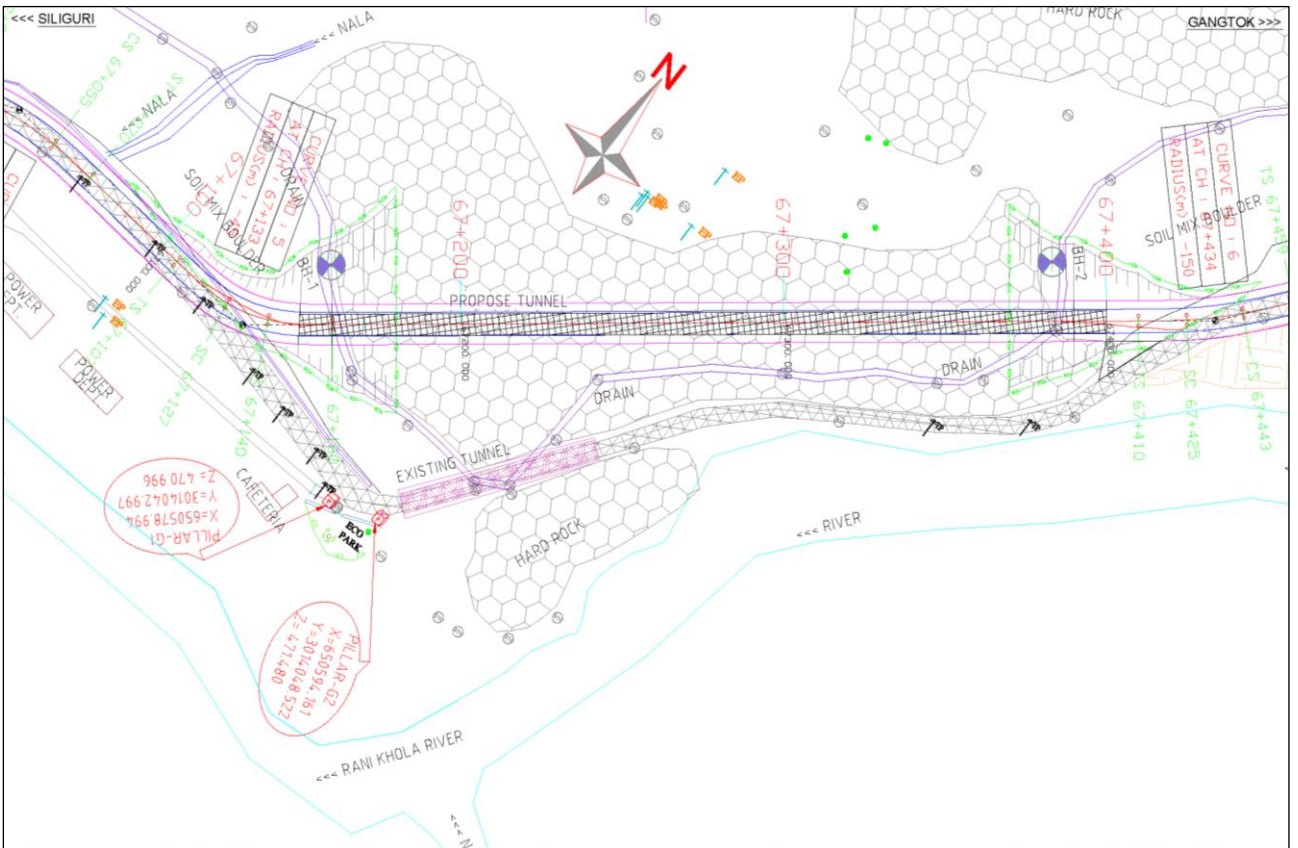

Site survey Map at proposed Tunnel Location

Annex -I
(Schedule-A)

Annex -I: Site

[Note: Through suitable drawings and description in words, the land, buildings, structures and road works comprising the Site shall be specified briefly but precisely in this Annex-I. All the chainages/ location referred to in Annex-I to Schedule-A shall be existing chainages.]

1. Site

The Site of the [Two-Lane] Project Highway comprises the section of [National Highway -10] commencing from Km 64+040 to Km 67+460 i.e. the Singtam - Ranipool section in the State of Sikkim. **Construction of Two Lane "Chisopani Traffic Tunnel" of Length 250 m including approaches from Km 67+080 to Km 67+500 on NH-10 in East District of Sikkim State on EPC mode.** The land, carriageway and structures comprising the Site are described below.

2. Land

The Site of the Project Highway comprises the land (sum total of land already in possession and land to be possessed) as described below:

Sl. No.	Existing Chainage (km)		Design Chainage (km)		Length in m (Design)	Existing/ Available ROW (m)	Remarks
	From	To	From	To			
1	64+040	67+460	64+040	67+460	420	24	ROW available in realignment stretches as given in para 3.3 of Annexure-1 Schedule B

3. Carriageway

The present carriageway of the Project Highway is [Single Lane]. The type of the existing pavement is [flexible].

Sl. No.	Existing Chainage (km)		Design Chainage (km)		Length in m (Design)	Lane Width (m)	Remarks
	From	To	From	To			
1	67+040	67+100	67+040	67+100	60	10	10 m formation with 7.0 m carriageway
2	67+100	67+200	67+100	67+430	330	10	10 m formation with 7.0 m carriageway

Sl. No.	Existing Chainage (km)		Design Chainage (km)		Length in m (Design)	Lane Width (m)	Remarks
	From	To	From	To			
3	67+200	67+470				6.0	Single lane
4	67+470	67+500	67+430	67+460	30	10	10 m formation with 7.0 m carriageway

4. Major Bridges

The Site includes the following Major Bridges:

S. No.	Chainage (km)	Type of Structure			No. of Spans with span length (m)	Width (m)
		Foundation	Sub-structure	Super-structure		
Nil						

5. Road over-bridges (ROB)/ Road under-bridges (RUB)

The Site includes the following ROB (road over railway line)/RUB (road under railway line):

S. No.	Chainage (km)	Type of Structure		No. of Spans with span length (m)	Width (m)	ROB/ RUB
		Foundation	Superstructure			
Nil						

6. Grade separators

The Site includes the following grade separators:

S. No.	Chainage (km)	Type of Structure		No. of Spans with span length (m)	Width (m)
		Foundation	Superstructure		
Nil					

7. Minor bridges

The Site includes the following minor bridges

S. No.	Chainage (km)	Type of Structure			No. of Spans with span length (m)	Width (m)
		Foundation	Sub-structure	Super-structure		
Nil						

8. Railway level crossings

The Site includes the following railway level crossings

S.No.	Location (km)	Remarks

9. Underpasses (vehicular, non vehicular)

The Site includes the following underpasses:

S.No.	Chainage (km)	Type of Structure	No. of Spans with span length (m)	Width (m)
Nil				

10. Culverts

The Site has the following culverts:

Sl. No.	Location (km)	Length (m)	Type of Structures	Span Arrangement and Total Ventway [No.x Length(m)]	Carriageway Width (m)	Width of Culvert (m)
Nil						

11. Bus bays

The details of bus bays on the Site are as follows:

S. No.	Chainage (km)	Length (m)	Left Hand Side	Right Hand Side
Nil				

12. Truck Lay byes

The details of truck lay byes are as follows:

S. No.	Chainage (km)	Length (m)	Left Hand Side	Right Hand Side
Nil				

13. Road side drains

The details of the roadside drains are as follows:

S. No.	Location		Type	
	From km	to km	Masonry/cc (Pucca)	Earthen (Kutcha)
1	67+040	67+420		Earthen drain on hill side

14. Major junctions

The details of major junctions are as follows:

S. No.	Location		At grade	Separated	Category of Cross Road			
	Existing Ch.	Design Ch.			NH	SH	MDR	Others
Nil								

(NH: National Highway, SH: State Highway, MDR: Major District Road)

15. Minor junctions

The details of the minor junctions are as follows:

Sl. No	Existing Chainage (Km)	Type	Type of junction	Place
Nil				

16. Bypasses

The details of the existing road sections proposed to be bypassed are as follows:

S. No.	Name of bypass (town)	Chainage (km) From km to km	Length (in Km)
Nil			

17. Other structures]

[Provide details of other structures, if any.]

Sr. No	Existing Chainage		Design Chainage		Remarks
	From	To	From	To	
1	67+211	67+273	67+180	67+242	Existing Tunnel having single lane carriageway

18. Built Up Locations

The following are the Built-up locations on the Project Road.

Sr.No.	Existing Chainage		Name	Design Chainage		District
	From	To		From	To	
1	67+040	67+500	Chisopani Village on Valley side	67+040	67+460	East Sikkim

Annex - II

(As per Clause 8.3 (i))

(Schedule-A)

Annex - II: Dates for providing Right of Way of Construction Zone

The dates on which the Authority shall provide Right of Way of Construction Zone to the Contractor on different stretches of the Site are stated below:

Sl. No	From km to km	Length (km)	Width (m)	Date of providing Right of Way*
(1)	(2)	(3)	(4)	(5)
(i) Full Right of Way (full width)	Km 67+040 to Km 67+460	0.42	24 m to 67 m	At Appointed Date
(a) Stretch				
(b) Stretch				
(c) Stretch				
(ii) Part Right of Way (part width)				
(a) Stretch				
(b) Stretch				
(c) Stretch				
(iii) Balance Right of Way (width)				
(a) Stretch				
(b) Stretch				
(c) Stretch				

*The dates specified herein shall in no case be beyond 150 (one hundred and fifty) days after the Appointed Date.

Annex - III

(Schedule-A)

Alignment Plans

The existing alignment of the Project Highway shall be modified in the following sections as per the alignment plan indicated below:

- (i) The alignment of the Project Highway is enclosed in alignment plan. Finished road level indicated in the alignment plan shall be followed by the contractor as minimum FRL. In any case, the finished road level of the project highway shall not be less than those indicated in the alignment plan. The contractor shall, however, improve/upgrade the Road profile as indicated in Annex-III based on site/design requirement.
- (ii) Traffic Signage plan of the Project Highway showing numbers & location of traffic signs is enclosed. The contractor shall, however, improve/upgrade upon the traffic signage plan as indicated in Annex-III based on site/design requirement as per IRC: SP: 99 & IRC: 67.

Annex - IV

(Schedule-A)

Environment Clearances

The project Highway does not require Environment Clearance as per MoRTH corrigendum dated 22.08.2013.

The muck dumping sites in forest area stand identified and freezed by Forest department to be abided by agency during dumping of muck as stated in Schedule 'F'

Schedule - B

(See Clause 2.1)

Development of the Project Highway

1. Development of the Project Highway

Development of the Project Highway shall include design and construction of the Project Highway as described in this Schedule-B and in Schedule-C.

2. [Rehabilitation and augmentation]

[Rehabilitation and augmentation] shall include Two-Laning with paved Shoulder and strengthening and construction of new two lane Traffic Tunnel at Chisopani of the Project Highway as described in Annex-I of this Schedule-B and in Schedule-C.

3. Specifications and Standards

The Project Highway shall be designed and constructed in conformity with the Specifications and Standards specified in Annex-I of Schedule-D.

4 As per Government of Sikkim Gazette Notification, **Blasting** is not allowed for road formation widening work. In case of any special situation, controlled blasting can be resorted with the prior permission of the concerned District Administration after taking all necessary safety measures.

Annex -I

(Schedule -B)

Annex -I: Description of [Two -Laning]

[Note: Description of the Project Highway shall be given by the Authority in detail together with explanatory drawings (where necessary) to explain the Authority's requirements precisely in order to avoid subsequent changes in the Scope of the Project. The particulars that must be specified in this Schedule-B are listed below as per the requirements of the Manual of Specifications and Standards for [Two Laning of Highways (IRC: SP: 73)], referred to as the Manual. If any standards, specifications or details are not given in the Manual, the minimum design/construction requirements shall be specified in this Schedule. In addition to these particulars, all other essential project specific details, as required, should be provided in order to define the Scope of the Project clearly and precisely.]

1. Widening of the Existing Highway

- (i) The Project Highway shall follow the existing alignment unless otherwise specified by the Authority and shown in the alignment plans specified in Annex-III of Schedule-A. Geometric deficiencies, if any, in the existing horizontal and vertical profiles shall be corrected as per the prescribed standards for [plain/rolling] terrain to the extent land is available.
- (ii) Width of Carriageway
- (a) Two-Laning with paved shoulders shall be undertaken. The paved carriageway shall be [7 (seven) m] wide in accordance with the typical cross sections drawings in the Manual.

Provided that in the built-up areas [refer to paragraphs 2.1 (ii) (a) of the Manual and provide necessary details]: the width of the carriageway shall be as specified in the following table:

Sl. No.	Built-up stretch (Township)	Location in m		Width (m)	Typical cross section (Ref. to Manual)
		From	To		
Nil					

- (b) Except as otherwise provided in this Agreement, the width of the paved carriageway and cross-sectional features shall conform to paragraph 1.1 above.

2. Geometric Design and General Features

- (i) General

Geometric design and general features of the Project Highway shall be in accordance with Section 2 of the Manual.

- (ii) Design speed

The design speed shall be the minimum design speed of 30 km per hr for Hilly terrain.

(iii) Improvement of the existing road geometrics

[Refer to paragraph 2.1 (v) of the Manual and provide details]

The hilly gradients shall be corrected in such a way so as to attain a limiting gradient of 6% in order to achieve longitudinal drainage. Also vertical curves shall be improved / introduced so that the vertical curves meet IRC: SP-73 - 2015 standards.

The horizontal alignment of the Project Highway shall be improved as per the standards set out in IRC-SP: 48:1998.

In the following sections, where improvement of the existing road geometrics to the prescribed standards is not possible, the existing road geometrics shall be improved to the extent possible within the given right of way and proper road signs and safety measures shall be provided:

Sl. No.	Stretch (from km to km)	Type of deficiency	Remarks
Nil			

(iv) Right of Way

[Refer to paragraph 2.3 of the Manual]. Details of the Right of Way are given in Annex II of Schedule-A.

(v) Type of shoulders

[Refer to paragraph 2.5.2 of the Manual and specify]

- (a) In built-up sections, footpaths/fully paved shoulders shall be provided in the following stretches:

Sl. No.	Stretch (from km to km)	Fully paved shoulders/ footpaths	Reference to cross section
Nil			

- (b) In open country, [paved shoulders of 1.5 m width shall be provided and balance 1.0m width shall be covered with 150 mm thick compacted layer of granular material].
- (c) Design and specifications of paved shoulders and granular material shall conform to the requirements specified in paragraphs 5.9.9 and 5.9.10 of the Manual.

(vi) Lateral and vertical clearances at underpasses

- (a) Lateral and vertical clearances at underpasses and provision of guardrails / crash barriers shall be as per paragraph 2.11 of the Manual.
- (b) Lateral clearance: The width of the opening at the underpasses shall be as follows:

Sl. No	Location (Chainage) (from km to km)	Span/ opening (m)	Remarks
Nil			

(vii) Lateral and vertical clearances at overpasses

- (a) Lateral and vertical clearances at overpasses shall be as per paragraph 2.12 of the Manual.
- (b) Lateral clearance: The width of the opening at the overpasses shall be as follows:

Sl. No.	Location (Chainage) (from km to km)	Span/ opening (m)	Remarks
Nil			

(viii) Service roads

Service roads shall be constructed at the locations and for the lengths indicated below: [Refer to paragraph 2.13 of the Manual and provide details]

Sl. No.	Location of service road (from km to km)	Right hand side (RHS)/Left hand side (LHS)/ or Both sides	Length (km) of service road
Nil			

(ix) Grade separated structures

- a. Grade separated structures shall be provided as per paragraph 2.14 of the Manual. The requisite particulars are given below:

[Refer to paragraphs 2.14.1 of the Manual and provide details]

Sl. No.	Location of structure	Length (m)	Number and length of spans	Approach gradient	Remarks, if any
Nil					

- b. In the case of grade separated structures, the type of structure and the level of the Project Highway and the cross roads shall be as follows: [Refer to paragraphs 2.14.2 of the Manual and specify the type of vehicular under pass/ overpass structure and whether the cross road is to be carried at the existing level, raised or lowered]

Sl. No.	Location	Type of structure Length (m)	Cross road at			Remarks, if any
			Existing Level	Raised Level	Lowered Level	
Nil						

(x) Cattle and pedestrian underpass / overpass

Cattle and pedestrian underpass/ overpass shall be constructed as follows: [Refer to paragraphs 2.14.3 of the Manual and specify the requirements of cattle and pedestrian underpass/ overpass]

Sl. No.	Location	Type of crossing
Nil		

(xi) Typical cross-sections of the Project Highway

[Give typical cross-sections of the Project Highway by reference to the Manual]

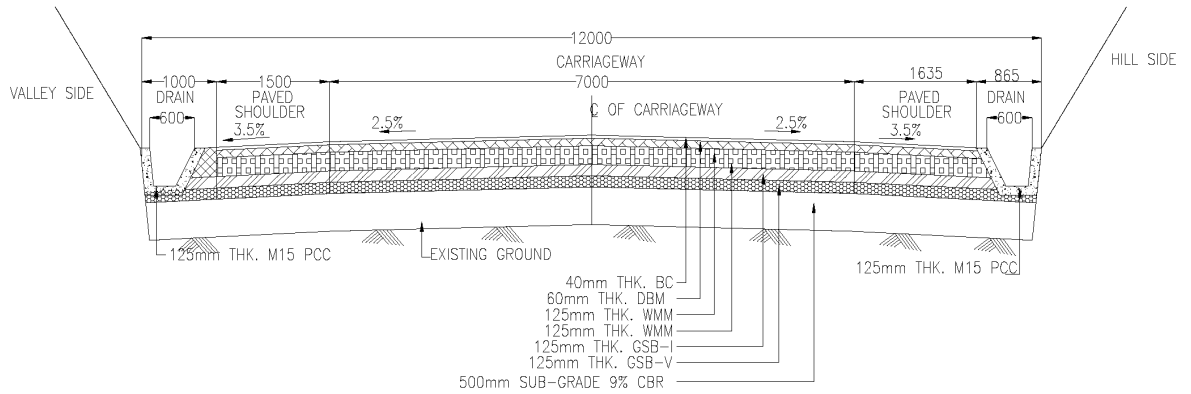

3. Intersections and Grade Separators

All intersections and grade separators shall be as per Section 3 of the Manual. Existing intersections which are deficient shall be improved to the prescribed standards.

[Refer to paragraphs 3.1.1, 3.1.2 and 3.3 of the Manual and specify the requirements. Explain where necessary with drawings/sketches/general arrangement]

Properly designed intersections shall be provided at the locations and of the types and features given in the tables below:

- (i) At-grade intersections

Sl. No.	Location of intersection	Type of intersection	Other features
Nil			

- (ii) Grade separated intersection with/without ramps

Sl. No.	Location	Salient features	Minimum length of viaduct to be provided	Road to be carried over/under the structures
Nil				

4. Road Embankment and Cut Section

- (i) Widening and improvement of the existing road embankment/cuttings and construction of new road embankment/cuttings shall conform to the Specifications and Standards given in Section 4 of the Manual and the specified cross sectional details. Deficiencies in the plan and profile of the existing road shall be corrected.

- (ii) Raising of the existing road [Refer to paragraph 4.2.2 of the Manual and specify sections to be raised]

The existing road shall be raised in the following sections:

Sl. No.	Section (from km to km)	Length	Extent of raising [Top of finished road level]
Nil			

5. Pavement Design

(i) Pavement design shall be carried out in accordance with Section 5 of the Manual.

(ii) Type of pavement

[Refer to paragraph 5.1 of the Manual and state specific requirement, if any, of providing cement concrete pavement.]

(iii) Design requirements

[Refer to paragraph 5.4, 5.9 and 5.10 of the Manual and specify design requirements and strategy]

(a) Design Period and strategy

Flexible pavement for new pavement or for widening and strengthening of the existing pavement shall be designed for a minimum design period of 15 years. Stage construction shall not be permitted.

The successful bidders under EPC mode can use any type of four flexible pavement mentioned in clause 2.2 of IRC :37-2012. They may carried out their own diligence to arrive at Project cost before submitting bids

(b) Design Traffic

Notwithstanding anything to the contrary contained in this Agreement or the Manual, the Contractor shall design the pavement for design traffic of 20 million standard axles.

(iv) Reconstruction of stretches

[Refer to paragraph 5.9.7 of the Manual and specify the stretches, if any, to be reconstructed.]

The following stretches of the existing road shall be reconstructed. These shall be designed as new pavement.

Sr.No.	Stretch in Km		Remarks
	From	To	
1	67+040	67+460	Construction of new pavement

6. Roadside Drainage

Drainage system including surface and subsurface drains for the Project Highway shall be provided as per Section 6 of the Manual.

The improvements in the drainage and the slope erosion shall be made as per the following norms:

Open side trapezoidal lined cross section drain shall be provided on hill sides of the project highway in order to intercept surface water from the carriageway, shoulders and hill slopes. The drains outfall into the natural water courses i.e. either in culverts or bridges. Table below gives the location of lined drains.

These are guidelines for minimum provisions. However, contractor has to design as per requirement of road in accordance with manual.

Sr.No.	Chainage in m		Length	Remarks
	From	To		
1	67+040	67+460	170	Trapezoidal Drain line drain excluding Tunnel portion

Note: (The above locations shall be reviewed in consultation with the Independent Consultant at the time of construction as per the site condition).

7. Design of Structures

(i) General

(a) All bridges, culverts and structures shall be designed and constructed in accordance with Section 7 of the Manual and shall conform to the cross-sectional features and other details specified therein.

(b) Width of the carriageway of new bridges and structures shall be as follows:

[Refer to paragraph 7.1 (ii) of the Manual and specify the width of carriageway of new bridges and structures of more than 60 (sixty) metre length, if the carriageway width is different from 7.5 (seven point five) metres in the table below.]

Sr.No.	Bridge at Km	Width of carriageway and cross-sectional features*
Nil		

(c) The following structures shall be provided with footpaths:

[Refer to paragraph 7.1 (iii) of the Manual and provide details of new Structures with footpath.]

Sr.No.	Location at Km	Remarks
Nil		

(d) All bridges shall be high-level bridges.

[Refer to paragraph 7.1 (iv) of the Manual and state if there is any exception]

(e) The following structures shall be designed to carry utility services specified in table below:

[Refer to paragraph 7.1 (viii) of the Manual and provide details]

Sr.No.	Bridge at Km	Utility services to be carried	Remarks
Nil			

(f) Cross-section of the new culverts and bridges at deck level for the Project Highway shall conform to the typical cross-sections given in section 7 of the Manual.

(ii) Culverts

(a) Overall width of all culverts shall be equal to the roadway width of the approaches.

(b) Reconstruction of existing culverts:

The existing culverts at the following locations shall be re-constructed as new culverts:

[Refer to paragraph 7.3 (i) of the Manual and provide details]

Sl.No.	Culvert location	Span/Openings(m)	Remarks, if any
Nil			

Note: (The above locations and size shall be reviewed in consultation with the Independent Consultant at the time of construction as per the site condition).

(c) Widening of existing culverts:

All existing culverts which are not to be reconstructed shall be widened to the roadway width of the Project Highway as per the typical cross section given in section 7 of the Manual. Repairs and strengthening of existing structures where required shall be carried out.

Sl. No	Culvert location	Type,span,height and width of existing culvert	Repairs to be carried out
Nil			

(d) Additional new culverts shall be constructed as per particulars given in the table below:

Sl.No.	Culvert Location	Span/Opening (m)
Nil		

Note: (The above locations and size shall be reviewed in consultation with the Independent Consultant at the time of construction as per the site condition).

(e) Repairs/replacements of railing/parapets, flooring and protection works of the existing culverts shall be undertaken as follows:

[Refer to paragraph 7.23 of the Manual and provide details]

Sl.No.	Location at Km	Type of repair required
Nil		

(f) Floor protection works shall be as specified in the relevant IRC Codes and Specifications

(iii) Bridges

(a) Existing bridges to be re- constructed/ widened

(i) The existing bridges at the following locations shall be re-constructed as new Structures]

[Refer to paragraph 7.3.2 of the Manual and provide details]

Sl. No	Bridge Location(Km)	Salient details of existing bridge	Adequacy or otherwise of the existing waterway, vertical clearance, etc	Remarks
Nil				

*Attach GAD

(ii) The following narrow bridges shall be widened:

Sl. No.	Location (km)	Existing width (m)	Extent of widening (m)	Cross-section at deck level for widening @
Nil				

@ Attach cross-section

- (b) Additional new bridges

[Specify additional new bridges if required, and attach GAD]

New bridges at the following locations on the Project Highway shall be constructed. GADs for the new bridges are attached in the drawings folder.

S/N	Location in m	Super structure	Foundation	Remarks	Span Arrangement	Remarks
Nil						

- (c) The railings of existing bridges shall be replaced by crash barriers at the following locations:

[Refer to paragraph 7.18 (iv) the Manual and provide details:]

Sl. No.	Location at Km	Remarks, if any
Nil		

- (d) Repairs/replacements of railing/parapets of the existing bridges shall be undertaken as follows:

[Refer to paragraph 7.18 (v) the Manual and provide details]

Sl. No.	Location at Km	Remarks, if any
Nil		

- (e) Drainage system for bridge decks

An effective drainage system for bridge decks shall be provided as specified in paragraph 7.21 of the Manual

- (f) Structures in marine environment

[Refer to paragraph 7.22 of the Manual and specify the necessary measures / treatments for protecting structures in marine environment, where applicable]

- (iv) Rail-road bridges

- (a) Design, construction and detailing of ROB/RUB shall be as specified in section 7 of the Manual.[Refer to paragraph 7.19 of the Manual and specify modification, if any]

- (b) Road over-bridges

Road over-bridges (road over rail) shall be provided at the following level crossings, as per GAD drawings attached:

Sl. No.	Location of Level crossing (Chainage Km)	Length of bridge (m)
Nil		

- (c) Road under-bridges

Road under-bridges (road under railway line) shall be provided at the following level crossings, as per GAD drawings attached:

Sl. No.	Location of Level crossing (Chainage Km)	Number and length of span (m)
Nil		

- (v) Grade separated structures
[Refer to paragraph 7.20 of the Manual]

The grade separated structures shall be provided at the locations and of the type and length specified in paragraphs 2.9 and 3 of this Annex-I.

- (vi) (vi) Repairs and strengthening of bridges and structures
[Refer to paragraph 7.23 of the Manual and provide details]

The existing bridges and structures to be repaired/strengthened, and the nature and extent of repairs /strengthening required are given below:

- (a) Bridges

Sl. No.	Location of bridge (km)	Nature and extent of repairs /strengthening to be carried out
Nil		

- (b) ROB/RUB

Sl. No.	Location of ROB/RUB (km)	Nature and extent of repairs /strengthening to be carried out
Nil		

- (c) Overpasses/Underpasses and other structures

- (d)

Sl. No.	Location of structure (km)	Nature and extent of repairs /strengthening to be carried out
Nil		

- (vii) List of Major Bridges and Structures

The following is the list of the Major Bridges and Structures:

Sl.No.	Location	Span arrangement	Remarks
1	67+150 to 67+400	10 m inlet portal +230 m Tunnel +10 m outlet portal	New alignment Tunnel having width in inner width 12.0 m A clearance profile with a height of 5.5 m over the carriageway. The width of the carriage way of 7.5m width and both side walkways with cover drain 2.25m.

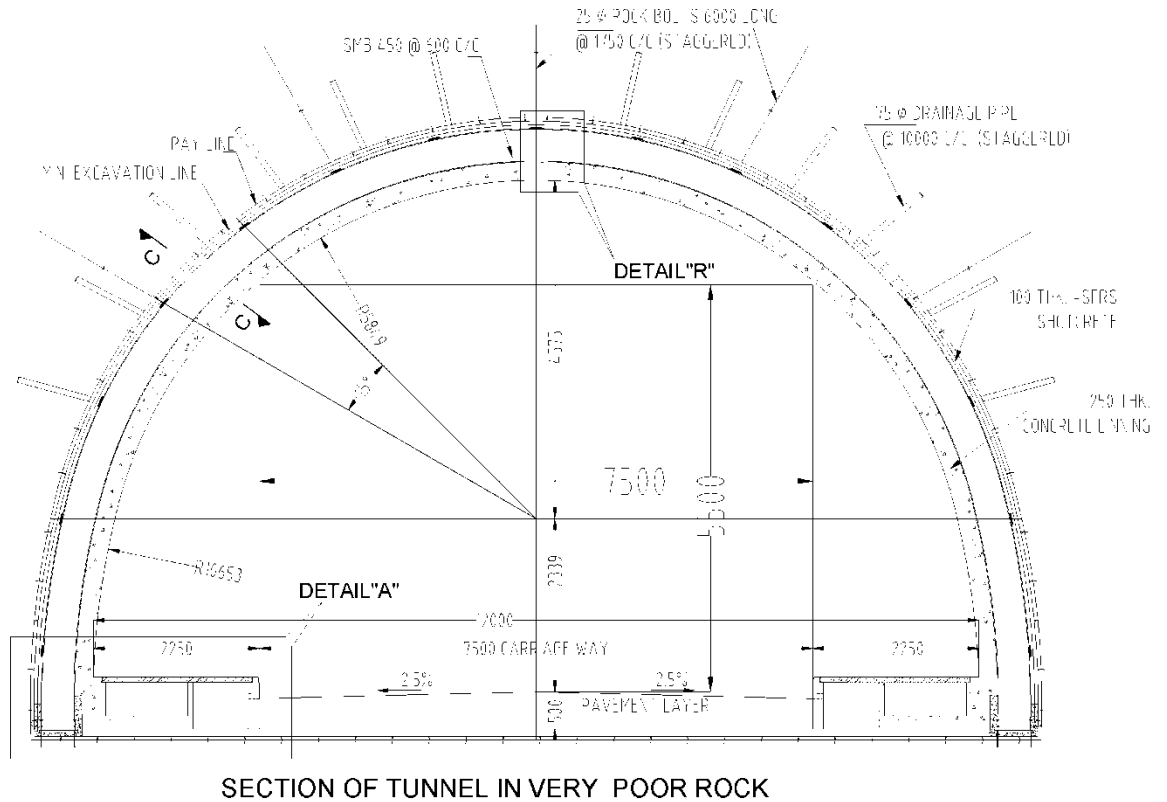

8. Traffic Control Devices and Road Safety Works

- (i) Traffic control devices and road safety works shall be provided in accordance with Section 9 of the Manual.
 - (ii) Specifications of the reflective sheeting. [Refer to paragraph 9.3 of the Manual and specify]
- The minimum quantity of Traffic signages and pavement marking are tabulated here

Sr.No.	Traffic Signages, Road Marking and other appurtenances	unit	Quantity
1	60 cm circular	each	2
2	Road Marking with Hot Applied Thermoplastic Compound with Reflectorising Glass	Sqm	105
3	Direction and Place Identification signs upto 0.9 sqm size board	Sqm	1

9. Roadside Furniture

- (i) Roadside furniture shall be provided in accordance with the provisions of Section 11 of the Manual.
- (ii) Overhead traffic signs: location and size
[Refer to paragraph 11.5 of the Manual and provide details]

10. Compulsory Afforestation

[Refer to paragraph 12.1 of the Manual and specify the number of trees which are required to be planted by the Contractor as compensatory afforestation.]

Minimum 50 nos. trees are required to be planted.

11. Hazardous Locations

The safety barriers shall also be provided at the following hazardous locations

Sl.No.	Location stretch from (Km) to (Km)	LHS/RHS
Nil		

12. Special Requirement for Hill Roads

12.1 Slope Protection Work

Describing the technical capability of the bidders related to execution of slope protection works for proper execution on ground has been incorporated as under:

- i. The contractor shall be responsible for accurate assessment of the actual requirement as per site situation and prepare design for slope protection and stabilization as per specification and standards stipulated in schedule-D and submit the same to the Authority's Engineer/Authority for review through the Proof Consultant and implement it accordingly thereafter
- ii. Any increase in quantity over and above the tentative quantity as mentioned in above table or through change in specifications will not be considered as change of scope. Therefore, Contractor shall make through investigation at site and assess the requirement of slope protection and slide prone zone and other safety feature at his own before submission of bid.
- iii. For executing any of the above type of slope protection works, the contractor should have the experience of having executed, in last 5 (five) financial years from the date of signing of Agreement, at least 40% quantity of that type of slope protection works and provide requisite certificates/documents to verify the same to the Authority/ Authority engineer.
- iv. If the Contractor does not have requisite experience for any/some of the above type of slope protection works, then he has to engage specialized firm(s) as sub-contractor(s) who has/have successfully completed in last 5(five) financial years at least 40% quantity of such works. The contractor shall submit the credentials and the qualifying experience of the specialized sub-contractor(s) for approval of Authority before the commencement of such slope protection works.

The minimum quantity of protection works may be taken as below

S.N	Side	Length in m	Height in m	Type of structure	Proposal
1	From 67+050 to 67+140	90.0	3.0	RRM Breast Wall	New
	From 67+400 to 67+460	60.0	3.0	RRM Breast Wall	New

Note: The wall length is indicative and shall be estimated by the EPC contractor.

13. Change of Scope

The length of Structures and bridges specified hereinabove shall be treated as an approximate assessment. The actual lengths as required on the basis of detailed

investigations shall be determined by the Contractor in accordance with the Specifications and Standards. Any variations in the lengths specified in this Schedule-B shall not constitute a Change of Scope, save and except any variations in the length arising out of a Change of Scope expressly undertaken in accordance with the provisions of Article 13.

14.Details of Utility Shifting:- NIL

Schedule - C

(See Clause 2.1)

Project Facilities

1. Project Facilities

The Contractor shall construct the Project Facilities in accordance with the provisions of this Agreement. Such Project Facilities shall include:

- (a) toll plaza[s];
- (b) roadside furniture;
- (c) pedestrian facilities;
- (d) tree plantation;
- (e) truck lay-byes;
- (f) bus-bays and bus shelters;
- (g) rest areas; and
- (h) others to be specified

2. Description of Project Facilities

Each of the Project Facilities is described below:

Sl. No.	Project Facility	Location	Design Requirements	Other essential details

Note: Provide adequate details of each Project Facility to ensure their design and completion in accordance with the project specific requirements and the provisions of the Manual.

(a) Toll Plaza

Toll plaza shall be designed as per the guidelines of section 10 of manual of the standards and specifications and it is provided at following locations:

S. No.	Toll Plaza Location (Design Chainage in Km)
	Nil

(b) Roadside Furniture

The roadside furniture shall be provided in accordance with section 9.0 of the Manual of the standards and Specifications.

(c) Pedestrian Facilities

The pedestrian crossing facilities shall be provided in accordance with clause 9.8 /12.2 of the 2 lane / 4 lane manual of Standards and Specifications and Typical Cross section details provided in Appendix BI.

(d) Landscaping and Tree Plantation

The landscaping and tree plantation shall be provided. The locations for these provisions shall be finalized in consultation with Independent Engineer.

(e) Truck Lay-byes

Truck lay byes shall be provided at the following locations.

Sr. No.	Proposed Ch.
Nil	

(f) Bus Bays

Bus-bays and shelters shall be provided in accordance with Clause 12.6 of the 2 Lane Manual of Standards and Specifications at following locations.

Sl. No.	Existing Chainage	Design Chainage	Sides	Village
Nil				

Note: * refer IRC SP-73:2015

(g) Rest Areas - Nil.**(h) Others**

Installation and Supply of 5 kW off Grid Solar Power Plant with control room for lighting arrangement system in tunnel as per standard specification of IRC-SP-91-2010.

Schedule - D

(See Clause 2.1)

Specifications and Standards

1. Construction

The Contractor shall comply with the Specifications and Standards set forth in Annex-I of this Schedule-D for construction of the Project Highway.

2. Design Standards

The Project Highway including Project Facilities shall conform to design requirements set out in the following documents:

[Manual of Specifications and Standards for Two Laning of Highways (IRC: SP: 73), referred to herein as the Manual]

[Note: Specify the relevant Manual, Specifications and Standards]

Code for Practice of Road Signs IRC 67:2001.

The Hill Road Manual IRC SP 48 -1998 should be referred.

THE NATIONAL GREEN TRIBUNAL PRINCIPAL BENCH, NEW DELHI on 01th Nov, 2018

Following recommendations and suggestions have been made for dumping muck & dumping yard:-

- a. Before dumping muck at the dumping yard first of all retaining/ gabion walls of specified capacity and suitable design should be constructed.
- b. All the dumping sites should be properly designed with retaining wall/gabion structures and should be maintained regularly in order to check the spillage of the muck down the slope and into the rivers and other places.
- c. Wherever boulders are rolling down along with much, gabion structures/retaining wall should have sufficient foundation and bottom width should be 4-5 m. Length of one gabion structure should not be more than 6-8 m. Wherever more length of gabion structure is required one gabion structure should be bound with another
- d. If any new dumping sites are identified in future, then the retaining / gabion structures should be constructed at suitable vertical interval of 5-6 m so that entire disposed muck may not exert pressure only at one wall/ toe wall rather the load of muck should be distributed on different walls.
- e. Angle of repose of muck should be maintained between 30 to 45. Long slopes should be intercepted to several short ones with the help of 1.5 to 2.0 m wide berms / terraces/ benches in between in order to maintain less than critical velocity for runoff water and simultaneously mass erosion with be controlled.

- f. The capacity/ volume of muck disposal site should be more than volume of muck to be disposed.
- g. Proper sign boards indicating the name, number, location, dumping capacity, etc. should be installed at all the dumping sites.
- h. Dumping sites which are full of their capacity they should be rehabilitated with local grass or shrubs. Jute geo textile (JGT) may also be used for establishment of vegetation at vulnerable sites.
- i. Gabion walls should be constructed above HFL of River. If slope is very high to construct a gabion wall then a RCC/stone masonry retaining wall should be given at bank of River after proper design including foundation. Height of this wall should be well above the HFL of River.
- j. Proper protection measures should be taken along with river-side stretch of the Nalupani area in order to stop spilling/falling of muck into the river.
- k. All construction sites should follow and comply with the provisions of the Construction and Demolition Waste Management Rules, 2016".

Annex -I

(Schedule-D)

Annex -I: Specifications and Standards for Construction

1. Specifications and Standards

All Materials, works and construction operations shall conform to the Manual of Specifications and Standards for [Two-Laning of Highways (IRC:SP:73)] referred to as the Manual „IRC:SP:91-2010, IRC 56-2011 and MORTH Specifications for Road and Bridge Works. Where the specification for a work is not given, Good Industry Practice shall be adopted to the satisfaction of the Authority's Engineer.

2. Deviations from the Specifications and Standards

- (i) The terms "Concessionaire", "Independent Engineer" and "Concession Agreement" used in the Manual shall be deemed to be substituted by the terms "Contractor", "Authority's Engineer" and "Agreement" respectively.
- (ii) [Notwithstanding anything to the contrary contained in Paragraph 1 above, the following Specifications and Standards shall apply to the Project Highway, and for purposes of this Agreement, the aforesaid Specifications and Standards shall be deemed to be amended to the extent set forth below:]
- (iii) [Note 1: Deviations from the aforesaid Specifications and Standards shall be listed out here. Such deviations shall be specified only if they are considered essential in view of project-specific requirements.]

Clause Referred in Manual	Item	Provision as per Manual	Modified Provision	Remarks
2.2.1	Minimum design speed in hilly terrain.	40 kmph	At some locations shown in drawing, where the horizontal curve radius is not meeting the criteria as per clause 2.9.4 and table 2.5 of IRC: SP: 73-2015.	Speed is restricted for Curve having radius less 50m.

Schedule - E

(See Clauses 2.1 and 14.2)

Maintenance Requirements

1. Maintenance Requirements

- (i) The Contractor shall, at all times maintain the Project Highway in accordance with the provisions of this Agreement, Applicable Laws and Applicable Permits.
- (ii) The Contractor shall repair or rectify any Defect or deficiency set forth in Paragraph 2 of this Schedule-E within the time limit specified therein and any failure in this behalf shall constitute non-fulfillment of the Maintenance obligations by the Contractor. Upon occurrence of any breach hereunder, the Authority shall be entitled to effect reduction in monthly lump sum payment as set forth in Clause 14.6 of this Agreement, without prejudice to the rights of the Authority under this Agreement, including Termination thereof.
- (iii) All Materials, works and construction operations shall conform to the MORTH Specifications for Road and Bridge Works, and the relevant IRC publications. Where the specifications for a work are not given, Good Industry Practice shall be adopted.

[Specify all the relevant documents]

2. Repair/rectification of Defects and deficiencies

The obligations of the Contractor in respect of Maintenance Requirements shall include repair and rectification of the Defects and deficiencies specified in Annex -I of this Schedule-E within the time limit set forth therein.

3. Other Defects and deficiencies

In respect of any Defect or deficiency not specified in Annex -I of this Schedule-E, the Authority's Engineer may, in conformity with Good Industry Practice, specify the permissible limit of deviation or deterioration with reference to the Specifications and Standards, and any deviation or deterioration beyond the permissible limit shall be repaired or rectified by the Contractor within the time limit specified by the Authority's Engineer.

4. Extension of time limit

Notwithstanding anything to the contrary specified in this Schedule-E, if the nature and extent of any Defect or deficiency justifies more time for its repair or rectification than the time specified herein, the Contractor shall be entitled to additional time in conformity with Good Industry Practice. Such additional time shall be determined by the Authority's Engineer and conveyed to the Contractor and the Authority with reasons thereof.

5. Emergency repairs/restoration

Notwithstanding anything to the contrary contained in this Schedule-E, if any Defect, deficiency or deterioration in the Project Highway poses a hazard to safety or risk of damage to property, the Contractor shall promptly take all reasonable measures for eliminating or minimizing such danger.

6. Daily inspection by the Contractor

The Contractor shall, through its engineer, undertake a daily visual inspection of the Project Highway and maintain a record thereof in a register to be kept in such form

and manner as the Authority's Engineer may specify. Such record shall be kept in safe custody of the Contractor and shall be open to inspection by the Authority and the Authority's Engineer at any time during office hours.

7. Pre-monsoon inspection / Post-monsoon inspection

The Contractor shall carry out a detailed pre-monsoon inspection of all bridges, culverts and drainage system before [1st June] every year in accordance with the guidelines contained in IRC: SP35. Report of this inspection together with details of proposed maintenance works as required on the basis of this inspection shall be sent to the Authority's Engineer before the [10th June] every year. The Contractor shall complete the required repairs before the onset of the monsoon and send to the Authority's Engineer a compliance report. Post monsoon inspection shall be done by the [30th September] and the inspection report together with details of any damages observed and proposed action to remedy the same shall be sent to the Authority's Engineer.

8. Repairs on account of natural calamities

All damages occurring to the Project Highway on account of a Force Majeure Event or wilful default or neglect of the Authority shall be undertaken by the Authority at its own cost. The Authority may instruct the Contractor to undertake the repairs at the rates agreed between the Parties.

Annex -I

(Schedule-E)

Annex -I: Repair/rectification of Defects and deficiencies

The Contractor shall repair and rectify the Defects and deficiencies specified in this Annex-I of Schedule-E within the time limit set forth in the table below.

Nature of Defect or deficiency		Time limit for repair/ rectification
ROADS		
(a)	Carriageway and paved shoulders	
(i)	Breach or blockade	Temporary restoration of traffic within 24 hours; permanent restoration within 15 (fifteen) days
(ii)	Roughness value exceeding 2,200 mm in a stretch of 1 km (as measured by a calibrated bump integrator)	120 (one hundred and twenty) days
(iii)	Potholes	24 (twenty four) hours
(iv)	Any cracks in road surface	15 (fifteen) days
(v)	Any depressions, rutting exceeding 10 mm in road surface	30 (thirty) days
(vi)	Bleeding/skidding	7 (seven) days
(vii)	Any other defect/distress on the road	15 (fifteen) days
(viii)	Damage to pavement edges	15 (fifteen) days
(ix)	Removal of debris, dead animals	6 (six) hours
(b)	Granular earth shoulders, side slopes, drains and culverts	
(i)	Variation by more than 1 % in the prescribed slope of camber/cross fall (shall not be less than the camber on the main carriageway)	7 (seven) days
(ii)	Edge drop at shoulders exceeding 40 mm	7 (seven) days
(iii)	Variation by more than 15% in the prescribed side (embankment) slopes	30 (thirty) days
(iv)	Rain cuts/gullies in slope	7 (seven) days
(v)	Damage to or silting of culverts and side drains	7 (seven) days
(vi)	Desilting of drains in urban/semi- urban areas	24 (twenty four) hours
(vii)	Railing, parapets, crash barriers	7 (seven) days (Restore immediately if causing safety hazard)
(c)	Road side furniture including road sign and pavement marking	
(i)	Damage to shape or position, poor visibility or loss of retro- reflectivity	48 (forty eight) hours

Nature of Defect or deficiency		Time limit for repair/ rectification
(ii)	Painting of km stone, railing, parapets, crash barriers	As and when required/ Once every year
(iii)	Damaged/missing signs road requiring replacement	7 (seven) days
(iv)	Damage to road mark ups	7 (seven) days
(d)	Road lighting	
(i)	Any major failure of the system	24 (twenty four) hours
(ii)	Faults and minor failures	8 (eight) hours
(e)	Trees and plantation	
(i)	Obstruction in a minimum head- room of 5 m above carriageway or obstruction in visibility of road signs	24 (twenty four)hours
(ii)	Removal of fallen trees from carriageway	4 (four) hours
(iii)	Deterioration in health of trees and bushes	Timely watering and treatment
(iv)	Trees and bushes requiring replacement	30 (thirty) days
(v)	Removal of vegetation affecting sight line and road structures	15 (fifteen) days
(f)	Rest area	
(i)	Cleaning of toilets	Every 4 (four) hours
(ii)	Defects in electrical, water and sanitary installations	24 (twenty four) hours
(g)	[Toll Plaza]	
(h)	Other Project Facilities and Approach roads	
(i)	Damage in approach roads, pedestrian facilities, truck lay- byes, bus-bays, bus-shelters, cattle crossings, [Traffic Aid Posts,Medical Aid Posts] and service roads	15 (fifteen) days
(ii)	Damaged vehicles or debris on the road	4 (four) hours
(iii)	Malfunctioning of the mobile crane	4 (four) hours
Bridges		
(a)	Superstructure	
(i)	Any damage, cracks, spalling/ scaling Temporary measures	within 48 (forty eight) hours
	Permanent measures	within 15 (fifteen) days or as specified by the Authority's Engineer
(b)	Foundations	
(i)	Scouring and/or cavitation	15 (fifteen) days
(c)	Piers, abutments, return walls and wing walls	
(i)	Cracks and damages including settlement and tilting, spalling, scaling	30 (thirty) days
(d)	Bearings (metallic) of bridges	

Nature of Defect or deficiency		Time limit for repair/ rectification
(i)	Deformation, damages, tilting or shifting of bearings	15 (fifteen) days Greasing of metallic bearings once in a year
(e)	Joints	
(i)	Malfunctioning of joints	15 (fifteen) days
(f)	Other items	
(i)	Deforming of pads in elastomeric bearings	7 (seven) days
(ii)	Gathering of dirt in bearings and joints; or clogging of spouts, weep holes and vent-holes	3 (three) days
(iii)	Damage or deterioration in kerbs, parapets, handrails and crash barriers	3 (three) days (immediately within 24 hours if posing danger to safety)
(iv)	Rain-cuts or erosion of banks of the side slopes of approaches	7 (seven) days
(v)	Damage to wearing coat	15 (fifteen) days
(vi)	Damage or deterioration in approach slabs, pitching, apron, toes, floor or guide bunds	30 (thirty) days
(vii)	Growth of vegetation affecting the structure or obstructing the waterway	15 (fifteen) days
(g)	Hill Roads	
(i)	Damage to retaining wall/breast wall	7 (seven) days
(ii)	Landslides requiring clearance	12 (twelve) hours
(iii)	Snow requiring clearance	24 (twenty four) hours
	Tunnel	
(a)	Tunnel Power Supply System(Mains)	
(i)	Any major failure of the system	24 hours
(ii)	Faults and minor failures	8 hours
(b)	Tunnel Traffic Control System	
(i)	Any major failure of the system	24 hours
(ii)	Faults and minor failures	8 hours
(c)	Tunnel Fire Safety System	
(i)	Any major Failure of the system	8 hours

[Note: Where necessary, the Authority may modify the time limit for repair/rectification, or add to the nature of Defect or deficiency before issuing the bidding document, with the approval of the competent authority.]

Schedule - F

(See Clause 4.1 (vii)(a))

Applicable Permits

1. Applicable Permits

- (i) The Contractor shall obtain, as required under the Applicable Laws, the following Applicable Permits:
 - (a) Permission of the State Government for extraction of boulders from quarry;
 - (b) Permission of Village Panchayats and Pollution Control Board for installation of crushers;
 - (c) Licence for use of explosives;
 - (d) Permission of the State Government for drawing water from river/reservoir;
 - (e) Licence from inspector of factories or other competent Authority for setting up batching plant;
 - (f) Clearance of Pollution Control Board for setting up batching plant;
 - (g) Clearance of Village Panchayats and Pollution Control Board for setting up asphalt plant;
 - (h) Permission of Village Panchayats and State Government for borrow earth; and
 - (i) Any other permits or clearances required under Applicable Laws.
- (ii) Applicable Permits, as required, relating to environmental protection and conservation shall have been procured by the Authority in accordance with the provisions of this Agreement.

Schedule - G

(See Clauses 7.1 and 19.2)

Annex-I : Form of Bank Guarantee

(See Clause 7.1)

[Performance Security /Additional Performance Security]

The Managing Director,
National Highways & Infrastructural Development Corporation Ltd.
PTI Building, 3rd Floor,
4, Parliament Street
New Delhi - 110001

WHEREAS:

- (A) _____ [name and address of contractor] (hereinafter called the "**Contractor**") and [name and address of the authority], (hereinafter called the "**Authority**") have entered into an agreement (hereinafter called the "**Agreement**") for **Construction of Two Lane "Chisopani Traffic Tunnel" of Length 250 m including approaches from Km 67+080 to Km 67+500 on NH-10 in East District of Sikkim State on EPC mode** on Engineering, Procurement and Construction (the "**EPC**") basis, subject to and in accordance with the provisions of the Agreement
- (B) The Agreement requires the Contractor to furnish a Performance Security for due and faithful performance of its obligations, under and in accordance with the Agreement, during the {Construction Period/ Defects Liability Period and Maintenance Period} (as defined in the Agreement) in a sum of Rs _____ cr. (Rupees _____ crore) (the "**Guarantee Amount**").
- (C) We, _____ through our branch at _____ (the "**Bank**") have agreed to furnish this bank guarantee (*hereinafter called the "Guarantee"*) by way of Performance Security.

NOW, THEREFORE, the Bank hereby, unconditionally and irrevocably, guarantees and affirms as follows:

1. The Bank hereby unconditionally and irrevocably guarantees the due and faithful performance of the Contractor's obligations during the {Construction Period/Defects Liability Period and Maintenance Period} under and in accordance with the Agreement, and agrees and undertakes to pay to the Authority, upon its mere first written demand, and without any demur, reservation, recourse, contest or protest, and without any reference to the Contractor, such sum or sums up to an aggregate sum of the Guarantee Amount as the Authority shall claim, without the Authority being required to prove or to show grounds or reasons for its demand and/or for the sum specified therein.
2. A letter from the Authority, under the hand of an officer not below the rank of [General Manager in the National Highways & Infrastructures Development Corporation Ltd], that the Contractor has committed default in the due and faithful performance of all or any of its obligations under and in accordance with the Agreement shall be conclusive, final and binding on the Bank. The Bank further agrees that the Authority shall be the sole judge as

to whether the Contractor is in default in due and faithful performance of its obligations during and under the Agreement and its decision that the Contractor is in default shall be final and binding on the Bank, notwithstanding any differences between the Authority and the Contractor, or any dispute between them pending before any court, tribunal, arbitrators or any other authority or body, or by the discharge of the Contractor for any reason whatsoever.

3. In order to give effect to this Guarantee, the Authority shall be entitled to act as if the Bank were the principal debtor and any change in the constitution of the Contractor and/or the Bank, whether by their absorption with any other body or corporation or otherwise, shall not in any way or manner affect the liability or obligation of the Bank under this Guarantee.
4. It shall not be necessary, and the Bank hereby waives any necessity, for the Authority to proceed against the Contractor before presenting to the Bank its demand under this Guarantee.
5. The Authority shall have the liberty, without affecting in any manner the liability of the Bank under this Guarantee, to vary at any time, the terms and conditions of the Agreement or to extend the time or period for the compliance with, fulfillment and/ or performance of all or any of the obligations of the Contractor contained in the Agreement or to postpone for any time, and from time to time, any of the rights and powers exercisable by the Authority against the Contractor, and either to enforce or forbear from enforcing any of the terms and conditions contained in the Agreement and/or the securities available to the Authority, and the Bank shall not be released from its liability and obligation under these presents by any exercise by the Authority of the liberty with reference to the matters aforesaid or by reason of time being given to the Contractor or any other forbearance, indulgence, act or omission on the part of the Authority or of any other matter or thing whatsoever which under any law relating to sureties and guarantors would but for this provision have the effect of releasing the Bank from its liability and obligation under this Guarantee and the Bank hereby waives all of its rights under any such law.
6. This Guarantee is in addition to and not in substitution of any other guarantee or security now or which may hereafter be held by the Authority in respect of or relating to the Agreement or for the fulfillment, compliance and/or performance of all or any of the obligations of the Contractor under the Agreement.
7. Notwithstanding anything contained hereinbefore, the liability of the Bank under this Guarantee is restricted to the Guarantee Amount and this Guarantee will remain in force for the period specified in paragraph 8 below and unless a demand or claim in writing is made by the Authority on the Bank under this Guarantee all rights of the Authority under this Guarantee shall be forfeited and the Bank shall be relieved from its liabilities hereunder.
8. The Guarantee shall cease to be in force and effect on ****². Unless a demand or claim under this Guarantee is made in writing before expiry of the Guarantee, the Bank shall be discharged from its liabilities hereunder.
9. The Bank undertakes not to revoke this Guarantee during its currency, except with the previous express consent of the Authority in writing, and declares and warrants that it has the power to issue this Guarantee and the undersigned has

² Insert date being 2 (two) years from the date of issuance of this Guarantee (in accordance with Clause 7.2 of the Agreement).

full powers to do so on behalf of the Bank.

10. Any notice by way of request, demand or otherwise hereunder may be sent by post addressed to the Bank at its above referred branch, which shall be deemed to have been duly authorised to receive such notice and to effect payment thereof forthwith, and if sent by post it shall be deemed to have been given at the time when it ought to have been delivered in due course of post and in proving such notice, when given by post, it shall be sufficient to prove that the envelope containing the notice was posted and a certificate signed by an officer of the Authority that the envelope was so posted shall be conclusive.
11. This Guarantee shall come into force with immediate effect and shall remain in force and effect for up to the date specified in paragraph 8 above or until it is released earlier by the Authority pursuant to the provisions of the Agreement.
12. This guarantee shall also be operatable at our..... Branch at New Delhi, from whom, confirmation regarding the issue of this guarantee or extension / renewal thereof shall be made available on demand. In the contingency of this guarantee being invoked and payment there under claimed, the said branch shall accept such invocation letter and make payment of amounts so demanded under the said invocation.
13. Bank Guarantee has been sent to authority's bank through SFMS gateway as per the details below:-

Sl. No	Particulars	Details
1	Name of the Beneficiary	National Highways and Infrastructure Development Corporation Limited
2	Beneficiary Bank Account No.	90621010002659
3	Beneficiary Bank Branch	IFSC SYNB0009062
4	Beneficiary Bank Branch Name	Transport Bhawan, New Delhi
5	Beneficiary Bank Address	Syndicate Bank, Transport Bhawan, 1 st Parliament street, New Delhi-110001

Signed and sealed this _____ day of, 20_____ at _____

SIGNED, SEALED AND DELIVERED

For and on behalf of the Bank by:

(Signature)

(Name)

(Designation)

(Code Number)

(Address)

NOTES:

- (i) The bank guarantee should contain the name, designation and code number of the officer(s) signing the guarantee.

- (ii) The address, telephone number and other details of the head office of the Bank as well as of issuing branch should be mentioned on the covering letter of issuing branch.

Annex - II
(Schedule - G)
(See Clause 19.2)

Annex - II: Form for Guarantee for Advance Payment

The Managing Director,
National Highways & Infrastructural Development Corporation Ltd.
PTI Building, 3rd Floor,
4, Parliament Street

WHEREAS:

- (A) [name and address of contractor] (hereinafter called the "**Contractor**") has executed an agreement (hereinafter called the "**Agreement**") with the [name and address of the authority], (hereinafter called the "**Authority**") for **Construction of Two Lane "Chisopani Traffic Tunnel" of Length 250 m including approaches from Km 67+080 to Km 67+500 on NH-10 in East District of Sikkim State on EPC mode** on Engineering, Procurement and Construction (the "**EPC**") basis, subject to and in accordance with the provisions of the Agreement
- (B) In accordance with Clause 19.2 of the Agreement, the Authority shall make to the Contractor an interest bearing @Bank Rate + 3% advance payment (herein after called "**Advance Payment**") equal to 10% (ten per cent) of the Contract Price; and that the Advance Payment shall be made in two installments subject to the Contractor furnishing an irrevocable and unconditional guarantee by a scheduled bank for an amount equivalent to 110% (one hundred and ten percent) of such installment to remain effective till the complete and full repayment of the installment of the Advance Payment as security for compliance with its obligations in accordance with the Agreement. The amount of {first/second} installment of the Advance Payment is Rs._____cr. (Rupees_____crore) and the amount of this Guarantee is Rs._____cr. (Rupees_____crore) (the "**Guarantee Amount**")³.
- (C) We,through our branch at.....(the "**Bank**") have agreed to furnish this bank guarantee (hereinafter called the "**Guarantee**") for the Guarantee Amount.

NOW, THEREFORE, the Bank hereby, unconditionally and irrevocably, guarantees and affirms as follows:

- The Bank hereby unconditionally and irrevocably guarantees the due and faithful repayment on time of the aforesaid instalment of the Advance Payment under and in accordance with the Agreement, and agrees and undertakes to pay to the Authority, upon its mere first written demand, and without any demur, reservation, recourse, contest or protest, and without any reference to the Contractor, such sum or sums up to an aggregate sum of the Guarantee Amount as the Authority shall claim, without the Authority being required to prove or to show grounds or reasons for its demand and/or for the sum specified therein.

A letter from the Authority, under the hand of an officer not below the rank of [General

³ The Guarantee Amount should be equivalent to 110% of the value of the applicable instalment

Manager in the National Highways & Infrastructures Development Corporation Ltd.], that the Contractor has committed default in the due and faithful performance of all or any of its obligations for the repayment of the instalment of the Advance Payment under and in accordance with the Agreement shall be conclusive, final and binding on the Bank. The Bank further agrees that the Authority shall be the sole judge as to whether the Contractor is in default in due and faithful performance of its obligations during and under the Agreement and its decision that the Contractor is in default shall be final and binding on the Bank, notwithstanding any differences between the Authority and the Contractor, or any dispute between them pending before any court, tribunal, arbitrators or any other authority or body, or by the discharge of the Contractor for any reason whatsoever

2. In order to give effect to this Guarantee, the Authority shall be entitled to act as if the Bank were the principal debtor and any change in the constitution of the Contractor and/or the Bank, whether by their absorption with any other body or corporation or otherwise, shall not in any way or manner affect the liability or obligation of the Bank under this Guarantee.
3. It shall not be necessary, and the Bank hereby waives any necessity, for the Authority to proceed against the Contractor before presenting to the Bank its demand under this Guarantee.
4. The Authority shall have the liberty, without affecting in any manner the liability of the Bank under this Guarantee, to vary at any time, the terms and conditions of the Advance Payment or to extend the time or period of its repayment or to postpone for any time, and from time to time, any of the rights and powers exercisable by the Authority against the Contractor, and either to enforce or forbear from enforcing any of the terms and conditions contained in the Agreement and/or the securities available to the Authority, and the Bank shall not be released from its liability and obligation under these presents by any exercise by the Authority of the liberty with reference to the matters aforesaid or by reason of time being given to the Contractor or any other forbearance, indulgence, act or omission on the part of the Authority or of any other matter or thing whatsoever which under any law relating to sureties and guarantors would but for this provision have the effect of releasing the Bank from its liability and obligation under this Guarantee and the Bank hereby waives all of its rights under any such law.
5. This Guarantee is in addition to and not in substitution of any other guarantee or security now or which may hereafter be held by the Authority in respect of or relating to the Advance Payment.
6. Notwithstanding anything contained hereinbefore, the liability of the Bank under this Guarantee is restricted to the Guarantee Amount and this Guarantee will remain in force for the period specified in paragraph 8 below and unless a demand or claim in writing is made by the Authority on the Bank under this Guarantee all rights of the Authority under this Guarantee shall be forfeited and the Bank shall be relieved from its liabilities hereunder.
7. The Guarantee shall cease to be in force and effect on ****⁴ Unless a demand or claim under this Guarantee is made in writing on or before the aforesaid date, the Bank shall be discharged from its liabilities hereunder.
8. The Bank undertakes not to revoke this Guarantee during its currency, except

⁴ Insert a date being 90 (ninety) days after the end of one year from the date of payment of the Advance payment to the Contractor (in accordance with Clause 19.2 of the Agreement).

with the previous express consent of the Authority in writing, and declares and warrants that it has the power to issue this Guarantee and the undersigned has full powers to do so on behalf of the Bank.

9. Any notice by way of request, demand or otherwise hereunder may be sent by post addressed to the Bank at its above referred branch, which shall be deemed to have been duly authorised to receive such notice and to effect payment thereof forthwith, and if sent by post it shall be deemed to have been given at the time when it ought to have been delivered in due course of post and in proving such notice, when given by post, it shall be sufficient to prove that the envelope containing the notice was posted and a certificate signed by an officer of the Authority that the envelope was so posted shall be conclusive.
10. This Guarantee shall come into force with immediate effect and shall remain in force and effect up to the date specified in paragraph 8 above or until it is released earlier by the Authority pursuant to the provisions of the Agreement.
11. This guarantee shall also be operatable at our..... Branch at New Delhi, from whom, confirmation regarding the issue of this guarantee or extension / renewal thereof shall be made available on demand. In the contingency of this guarantee being invoked and payment there under claimed, the said branch shall accept such invocation letter and make payment of amounts so demanded under the said invocation.
12. Bank Guarantee has been sent to authority's bank through SFMS gateway as per the details below:-

Sl. No	Particulars	Details
1	Name of the Beneficiary	National Highways and Infrastructure Development Corporation Limited
2	Beneficiary Bank Account No.	90621010002659
3	Beneficiary Bank Branch	IFSC SYNB0009062
4	Beneficiary Bank Branch Name	Transport Bhawan, New Delhi
5	Beneficiary Bank Address	Syndicate Bank, Transport Bhawan, 1 st Parliament street, New Delhi-110001

Signed and sealed this day of..., 20..... at

SIGNED, SEALED AND DELIVERED

For and on behalf of the Bank by:

(Signature)

(Name)

(Designation)

(Code Number)

(Address)

NOTES:

- (i) The bank guarantee should contain the name, designation and code number of the officer(s) signing the guarantee.
- (ii) The address, telephone number and other details of the head office of the Bank as well as of issuing branch should be mentioned on the covering letter of issuing branch.

Schedule - H

(See Clauses 10.1 (iv) and 19.3)

Contract Price Weightages

1. The Contract Price for this Agreement is Rs. *****

Proportions of the Contract Price for different stages of Construction of the Project Highway shall be as specified below:

Item	Weightage in % of CP	Stage for Payment		% Weightage	% Weightage vis Overall Project
1	2	3		4	5
Road works including culverts, widening and repair of culverts.	2.68%	A	Widening and strengthening of existing road	100.00%	
		1	Earthwork up to top of the sub-grade	4.48%	0.12%
		2	Earthwork in shoulders	0.78%	0.02%
		3	Sub-Base course	17.16%	0.46%
		4	Non Bituminous Base Course	15.29%	0.41%
		5	Bituminous Base Course	35.06%	0.94%
		6	Wearing Coat	27.23%	0.73%
		7	Widening and repair of culverts	0.00%	0.00%
Tunnel works	94.32%				
		A	Inlet and Outlet Portal	100.00%	
		1	Temporary Dewatering Arrangement	2.73%	0.29%
		2	Open Excavation and Earthwork	12.44%	1.34%
		3	Underground Excavation & over break in underground excavation for portal in Support Category dominating the Face Area	21.77%	2.34%
		4	Primary support measures (Bolts & Anchors, Shotcrete & Wire Mesh including Drilling and Grouting)	30.90%	3.33%
		5	Permanent Dewatering Arrangement	0.49%	0.05%
		6	Concrete Back filling & bed lining work	7.53%	0.81%
		7	RCC Concrete Works including reinforcement	21.10%	2.27%
		8	Pavement work & side drain	3.04%	0.33%
		B	Main Tunnel	100.00%	
		1	Temporary Dewatering Arrangement	2.77%	2.31%

Item	Weightage in % of CP	Stage for Payment		% Weightage	% Weightage vis Overall Project
1	2	3		4	5
		2	Underground Excavation & over break in underground excavation for portal in Support Category dominating the Face Area	31.85%	26.61%
		3	Permanent Dewatering Arrangement	3.85%	3.21%
		4	Primary support measures (Bolts & Anchors, Shotcrete & Wire Mesh including Drilling and Grouting)	12.08%	10.09%
		5	Concrete Back filling & bed lining work	14.84%	12.40%
		6	Fabricating and fixing in position permanent structural steel supports	26.18%	21.87%
		7	Precast RCC Lagginge M 20 grade	4.33%	3.62%
		8	Pavement work & side drain	4.10%	3.42%
Other works	3.00%	(i)	Toll plaza		
		(ii)	Road side drains	3.23%	0.10%
		(iii)	Road signs markings, km stones, safety devices,		
		a	Traffic Sign	2.05%	0.06%
		b	Lighting system in Tunnel	25.52%	0.77%
		(iv)	Project Facilities		
		(a)	Busbays		
		(b)	Truck lay-byes		
		(c)	Rest areas		
		(d)	Dismantling	0.99%	0.030%
		(e)	Site Clearing, setting, etc.	0.14%	0.004%
		(f)	Maintenance of existing Tunnel & Road	31.40%	0.942%
		(v)	Roadside plantation		
		a	Road side plantation & medium Plantation.		
		b	Plantation (Vetiver, Hydro seeding & Turfine etc.) for slope protection on exposed hill slopes as slide mitigation measure.		
		(vi)	Repair of protection works other than approaches to the bridges, elevated section/ flyovers/grade separators and ROBs.		

Item	Weightage in % of CP	Stage for Payment		% Weightage	% Weightage vis Overall Project
1	2	3		4	5
		(vii)	Safety and traffic management during construction		
		(viii)	Protection works		
		a	Breast wall	36.67%	1.10%

Procedure of estimating the value of work done.

(i) Road works

Procedure for estimating the value of road work done shall be as follows:

Table 1.3.1

	Stage of Payment	% weightage	Payment Procedure
A	Wideing and strengthening of existing road		Unit of measurement is linear length. Payment of each stage shall be made on pro rata basis on completion of a stage in a length of not less than 10 (ten) percent of the total length.
1	Earthwork up top of the sub-grade	4.48%	
2	Earthwork in shoulders	0.78%	
3	Sub-Base Course	17.16%	
4	Non Bituminous Base Course	15.29%	
5	Bituminous Base Course	35.06%	
6	Wearing Coat	27.23%	
7	Widening and repair of culverts	0.00%	Cost of ten completed culverts shall be determined on pro rata basis with respect to the total number of culverts. Payment shall be made on the completion of at least five culverts.

@ For calculation of payment stage for main-carriageway the project length shall be converted into equivalent 2 lane length. For example, if the total length of 4 lane main carriageway is 100 km, then the equivalent length for calculation of payment stage will be 2 x 100 km. Now, if the total length of bituminous work to be done is 100 km, the cost per km of bituminous work shall be determined as follows:

$$\text{Cost per km} = P \times \text{weightage for road work} \times \text{weightage for bituminous work} \times (1/L)$$

Where

P = Contract Price

L = Total equivalent 2-Lane length in km as defined above

Similarly, the rates per km for other stages shall be worked out accordingly.

Note: The length affected due to law and order problems or litigation during execution including the length not handed over to the Contractor under clause 8.3 of this Contract Agreement due to which the Contractor is unable to execute the work, may be deducted from the total project length for payment purposes. The total length calculated here is only for payment purposes and will not affect and referred in other clauses of the Contract Agreement.

(ii) Minor Bridges and Underpasses/Overpasses

Procedure for estimating the value of Minor bridge and Underpasses/Overpasses shall be as stated in table 1.3.2:

Table 1.3.2

Stage of Payment	% weightage	Payment Procedure
1	2	3
Nil		

(iii) Major Bridge works, ROB/RUB and Structures

Procedure for estimating the value of Major Bridge works, ROB/RUB and Structures Work shall be as stated in table 1.3.3:

Table 1.3.3

Sr. No.	Stage of Payment	% weightage	Payment Procedure
1	2	3	4
A	Portals (Inlet & outlet)		Unit of measurement is linear length. Payment shall be made on pro rata basis on completion of a stage in a length of not less than 10 (ten) percent of the total length.
1	Temporary Dewatering Arrangement	2.73%	
2	Open Excavation and Earthwork	12.44%	
3	Underground Excavation & over break in underground excavation for portal in Support Category dominating the Face Area	21.77%	
4	Primary support measures (Bolts & Anchors, Shotcrete & Wire Mesh including Drilling and Grouting)	30.90%	
5	Permanent Dewatering Arrangement	0.49%	
6	Concrete Back filling & bed lining work	7.53%	
7	RCC Concrete Works including reinforcement	21.10%	
8	Pavement work & side drain	3.04%	
B	Main Tunnel		Unit of measurement is linear length. Payment shall be made on pro rata basis on completion of a stage in a length of not less than 10 (ten) percent of the total length.
1	Temporary Dewatering Arrangement	2.77%	
2	Underground Excavation & over break in underground excavation for portal in Support Category dominating the Face Area	31.85%	
3	Permanent Dewatering Arrangement	3.85%	
4	Primary support measures (Bolts & Anchors, Shotcrete & Wire Mesh including Drilling and Grouting)	12.08%	
5	Concrete Back filling & bed lining work	14.84%	
6	Fabricating and fixing in position permanent structural steel supports	26.18%	
7	Precast RCC Lagging M 20 grade	4.33%	
8	Pavement work & side drain	4.10%	

(iv) Other Works.

Procedure for estimating the value of other works done shall be as stated in table 1.3.4:

Stage of Payment	% weightage	Payment Procedure
(i) Toll plaza	0.00%	Unit of measurement is each completed toll plaza. Payment of each toll plaza shall be made on pro rata basis with respect to the total of all toll plazas.

(ii)	Road side drains	3.23%	Unit of measurement is linear in k.m Payment shall be made on pro rata basis on completion of a stage in a length on not less than 10% (ten per cent) of the total length.
(iii)	Road signs markings, km stones, safety devices,		
a	Traffic Sign	2.05%	Unit of measurement is linear in km Payment shall be made on pro rata basis on completion of a stage in a length on not less than 10% (ten per cent) of the total length.
b	Lighting system in Tunnel	25.52%	On delivery, installation and commissioning of E&M equipment in the ratio of 20:40:40.
(iv)	Project Facilities		
(a)	Busbays	0.00%	Payment shall be made on pro rata basis for completed facilities.
(b)	Truck lay-byes	0.00%	
(c)	Rest areas	0.00%	
(d)	Dismantling	0.99%	
(e)	Site Clearing, setting, etc.	0.14%	
(f)	Maintenance of existing Tunnel & Road	31.40%	
(v)	Roadside plantation		
a	Road side plantation & medium Plantation.	0.00%	Unit of measurement is linear length payment shall be made on pro rata basis on completion of a stage in a length of not less than 10% (ten per cent) of the total length.
b	Plantation (Vetiver, Hydro seeding& Turfine etc.) for slope protection on exposed hill slopes as slide mitigation measure.	0.00%	
(vi)	Repair of protection works other than approaches to the bridges, elevated section/ flyovers/grade separators and ROBs.	0.00%	Unit of measurement is linear length payment shall be made on pro rata basis on completion of a stage in a length of not less than 10% (ten per cent) of the total length.
(vii)	Safety and traffic management during construction	0.00%	Payment shall be made on prorata basis every six months.
(viii)	Protection works		
a	Breast wall	36.67%	Unit of measurement is linear length. Payment shall be made on pro rata basis on completion of a stage in a length of not less than 10 (ten) percent of the total length.

2. Procedure for payment for Maintenance

(a) The cost for maintenance shall be as stated in Clause 14.1 (v).

Payment for Maintenance shall be made in accordance with the provisions of Article 14 and Article 19

Schedule -I

(See Clause 10.2 (iv))

Drawings

1. Drawings

In compliance of the obligations set forth in Clause 10.2 of this Agreement, the Contractor shall furnish to the Authority's Engineer, free of cost, all Drawings listed in Annex-I of this Schedule-I.

2. Additional Drawings

If the Authority's Engineer determines that for discharging its duties and functions under this Agreement, it requires any drawings other than those listed in Annex-I, it may by notice require the Contractor to prepare and furnish such drawings forthwith. Upon receiving a requisition to this effect, the Contractor shall promptly prepare and furnish such drawings to the Authority's Engineer, as if such drawings formed part of Annex-I of this Schedule-I.

Annex -I

(Schedule -I)

Annex -I: List of Drawings

[Note: The Authority shall describe in this Annex-I, all the Drawings that the contractor is required to furnish under Clause 10.2.]

A broad list of the drawings of the various components/elements of the Project Highway and project facilities required to be submitted by the Contractor is given below:

1. Index Map
2. Alignment Plan, Drawing of Horizontal Alignment, Vertical profile,
3. Typical Cross Section
4. General Arrangement Drawing
5. Dimension detailed drawing
6. Misc
 - (i) Road Signs & Road Delineators
 - (ii) Road/Kerb Markings
 - (iii) Typical Details of Drain
 - (iv) Typical Details of Metal Beam Crash Barrier
 - (v) Attainment of Super-elevation

Schedule - J

(See Clause 10.3 (ii))

Project Completion Schedule

1. Project Completion Schedule

During Construction period, the Contractor shall comply with the requirements set forth in this Schedule-J for each of the Project Milestones and the **Scheduled Completion Date**. Within 15 (fifteen) days of the date of each Project Milestone, the Contractor shall notify the Authority of such compliance along with necessary particulars thereof.

2. Project Milestone-I

- (i) Project Milestone-I shall occur on the date falling on the **[35% of the Scheduled Construction Period]** day from the Appointed Date (the "Project Milestone-I").
- (ii) Prior to the occurrence of Project Milestone-I, the Contractor shall have commenced construction of the Project Highway and submitted to the Authority duly and validly prepared Stage Payment Statements for an amount not less than 10% (ten per cent) of the Contract Price.

3. Project Milestone-II

- (i) Project Milestone-II shall occur on the date falling on the **[60% of the Scheduled Construction Period]** day from the Appointed Date (the "Project Milestone- II").
- (ii) Prior to the occurrence of Project Milestone-II, the Contractor shall have continued with construction of the Project Highway and submitted to the Authority duly and validly prepared Stage Payment Statements for an amount not less than 35% (thirty five per cent) of the Contract Price **and should have started construction of all bridges**

4. Project Milestone-III

- (i) Project Milestone-III shall occur on the date falling on the **[85% of the Scheduled Construction Period]** day from the Appointed Date (the "Project Milestone- III").
- (ii) Prior to the occurrence of Project Milestone-III, the Contractor shall have continued with construction of the Project Highway and submitted to the Authority duly and validly prepared Stage Payment Statements for an amount not less than 70% (seventy per cent) of the Contract Price and **should have started construction of all project facilities**.

5. Scheduled Completion Date

- (i) The Scheduled Completion Date shall occur on the [Scheduled Construction Period] day from the Appointed Date.
- (ii) On or before the Scheduled Completion Date, the Contractor shall have completed construction in accordance with this Agreement.

6. Extension of time

Upon extension of any or all of the aforesaid Project Milestones or the Scheduled Completion Date, as the case may be, under and in accordance with the provisions of this Agreement, the Project Completion Schedule shall be deemed to have been amended accordingly.

Schedule - K

(See Clause 12.1 (ii))

Tests on Completion

1. Schedule for Tests

- (i) The Contractor shall, no later than 30 (thirty) days prior to the likely completion of construction, notify the Authority's Engineer and the Authority of its intent to subject the Project Highway to Tests, and no later than 10 (ten) days prior to the actual date of Tests, furnish to the Authority's Engineer and the Authority detailed inventory and particulars of all works and equipment forming part of Works.
- (ii) The Contractor shall notify the Authority's Engineer of its readiness to subject the Project Highway to Tests at any time after 10 (ten) days from the date of such notice, and upon receipt of such notice, the Authority's Engineer shall, in consultation with the Contractor, determine the date and time for each Test and notify the same to the Authority who may designate its representative to witness the Tests. The Authority's Engineer shall thereupon conduct the Tests itself or cause any of the Tests to be conducted in accordance with Article 12 and this Schedule-K.

2. Tests

- (i) Visual and physical test: The Authority's Engineer shall conduct a visual and physical check of construction to determine that all works and equipment forming part thereof conform to the provisions of this Agreement. The physical tests shall include [***].
- (ii) Riding quality test: Riding quality of each lane of the carriageway shall be checked with the help of a Network Survey Vehicle (NSV) fitted with latest equipments and the maximum permissible roughness for purposes of this Test shall be [2,000 (two thousand)] mm for each kilometer.
- (iii) Tests for bridges: All major and minor bridges shall be subjected to the rebound hammer and ultrasonic pulse velocity tests, to be conducted in accordance with the procedure described in Special Report No. 17: 1996 of the IRC Highway Research Board on Nondestructive Testing Techniques, at two spots in every span, to be chosen at random by the Authority's Engineer. Bridges with a span of 15 (fifteen) meters or more shall also be subjected to load testing.
- (iv) Other tests: The Authority's Engineer may require the Contractor to carry out or cause to be carried additional tests, in accordance with Good Industry Practice, for determining the compliance of the Project Highway with Specifications and Standards, except tests as specified in clause 5, but shall include measuring the reflectivity of road markings and road signs; and measuring the illumination level (lux) of lighting using requisite testing equipment.
- (v) Environmental audit: The Authority's Engineer shall carry out a check to determine conformity of the Project Highway with the environmental requirements set forth in Applicable Laws and Applicable Permits.
- (vi) Safety Audit: The Authority's Engineer shall carry out, or cause to be carried out, a safety audit to determine conformity of the Project Highway with the safety requirements and Good Industry Practice.

3. Agency for conducting Tests

All Tests set forth in this Schedule-K shall be conducted by the Authority's Engineer or such other agency or person as it may specify in consultation with the Authority.

4. Completion Certificate

Upon successful completion of Tests, the Authority's Engineer shall issue the Completion Certificate in accordance with the provisions of Article 12.

5. The Authority Engineer will carry out tests with following equipment at his own cost in the presence of contractor's representative.

Sr. No.	Key metrics of Asset	Equipment to be used	Frequency of condition survey
1	Surface defects of pavement	Network Survey Vehicle (NSV)	At least twice a year (As per survey months defined for the state basis rainy season)
2	Roughness of pavement	Network Survey Vehicle (NSV)	At least twice a year (As per survey months defined for the state basis rainy season)
3	Strength of pavement	Falling Weight Deflectometer (FWD)	At least once a year
4	Bridges	Mobile Bridge Inspection Unit (MBU)	At least twice a year (As per survey months defined for the state basis rainy season)
5	Road signs	Retro-reflectometer	At least twice a year (As per survey months defined for the state basis rainy season)

The first testing with the help of NSV shall be conducted at the time of issue of Completion Certificate.

Schedule - L

(See Clause 12.2)

Completion Certificate

1. I,..... (Name of the Authority's Engineer), acting as the Authority's Engineer, under and in accordance with the Agreement dated.....(the "**Agreement**"), for [construction of the ****section (km ** to km **) of National Highway No. ***] (the "**Project Highway**") on Engineering, Procurement and Construction (EPC) basis through (Name of Contractor), hereby certify that the Tests in accordance with Article 12 of the Agreement have been successfully undertaken to determine compliance of the Project Highway with the provisions of the Agreement, and I am satisfied that the Project Highway can be safely and reliably placed in service of the Users thereof.
2. It is certified that, in terms of the aforesaid Agreement, all works forming part of Project Highway have been completed, and the Project Highway is hereby declared fit for entry into operation on this the day of20....., Scheduled Completed Date for which was the..... day of.....20.....

SIGNED, SEALED AND DELIVERED

For and on behalf of the Authority's Engineer by:

(Signature)

(Name)

(Designation) (Address)

Schedule - M

(See Clauses 14.6, 15.2 and 19.7)

Payment Reduction for Non-Compliance

1. Payment reduction for non-compliance with the Maintenance Requirements

- (i) Monthly lump sum payments for maintenance shall be reduced in the case of non-compliance with the Maintenance Requirements set forth in Schedule-E.
- (ii) Any deduction made on account of non-compliance with the Maintenance Requirements shall not be paid even after compliance subsequently. The deductions shall continue to be made every month until compliance is done.
- (iii) The Authority's Engineer shall calculate the amount of payment reduction on the basis of weightage in percentage assigned to non-conforming items as given in Paragraph 2.

2. Percentage reductions in lump sum payments on monthly basis

- (i) The following percentages shall govern the payment reduction:

S.No.	Item/Defect/Deficiency	Percentage
(a)	Carriageway/Pavement	
(i)	Potholes, cracks, other surface defects	15%
(ii)	Repairs of Edges, Rutting	5%
(b)	Road, Embankment, Cuttings, Shoulders	
(i)	Edge drop, inadequate cross fall, undulations, settlement, potholes, ponding, obstructions	10%
(ii)	Deficient slopes, raincuts, disturbed pitching, vegetation growth, pruning of trees	5%
(c)	Bridges and Culverts	
(i)	Desilting, cleaning, vegetation growth, damaged pitching, flooring, parapets, wearing course, footpaths, any damage to foundations	20%
(ii)	Any Defects in superstructures, bearings and sub-structures	10%
(iii)	Painting, repairs/replacement kerbs, railings, parapets, guideposts/crash barriers	5%
(d)	Roadside Drains	
(i)	Cleaning and repair of drains	5%
(e)	Road Furniture	
(i)	Cleaning, painting, replacement of road signs, delineators, road markings, 200 m/km/5 th km stones	5%
(f)	Miscellaneous Items	
(i)	Removal of dead animals, broken down/accidented vehicles, fallen trees, road blockades or malfunctioning of mobile crane	10%
(ii)	Any other Defects in accordance with paragraph 1.	5%
(g)	Defects in Other Project Facilities	5%

- (ii) The amount to be deducted from monthly lump-sum payment for non-compliance of particular item shall be calculated as under:

$$R = P / 100 \times (M1 \text{ or } M2) \times L1 / L$$

Where,

P= Percentage of particular item/Defect/deficiency for deduction

M1= Monthly lump-sum payment in accordance para 1.2 above of this Schedule

M2= Monthly lump-sum payment in accordance para 1.2 above of this Schedule

L1 = Non-complying length

L = Total length of the road,

R= Reduction (the amount to be deducted for non-compliance for a particular item/Defect/ deficiency)

The total amount of reduction shall be arrived at by summation of reductions for such items/Defects/deficiency or non-compliance.

For any defect in a part of one kilometer, the non-conforming length shall be taken as one kilometer.

Schedule - N

(See Clause 18.1 (i))

Selection of Authority's Engineer

1. Selection of Authority's Engineer

- (i) The provisions of the Model Request for Proposal for Selection of Technical Consultants, issued by the Ministry of Finance in May 2009, or any substitute thereof shall apply for selection of an experienced firm to discharge the functions and duties of an Authority's Engineer.
- (ii) In the event of termination of the Technical Consultants appointed in accordance with the provisions of Paragraph 1.1, the Authority shall appoint another firm of Technical Consultants forthwith and may engage a government-owned entity in accordance with the provisions of Paragraph 3 of this Schedule-N.

2. Terms of Reference

The Terms of Reference for the Authority's Engineer (the "TOR") shall substantially conform with Annex 1 to this Schedule N.

3. Appointment of Government entity as Authority's Engineer

Notwithstanding anything to the contrary contained in this Schedule, the Authority may in its discretion appoint a government-owned entity as the Authority's Engineer; provided that such entity shall be a body corporate having as one of its primary functions the provision of consulting, advisory and supervisory services for engineering projects; provided further that a government-owned entity which is owned or controlled by the Authority shall not be eligible for appointment as Authority's Engineer.

Annex -I (Schedule - N)

Annex -I: Terms of Reference for Authority's Engineer

1. Scope

- (i) These Terms of Reference (the "**TOR**") for the Authority's Engineer are being specified pursuant to the EPC Agreement dated..... (the "**Agreement**"), which has been entered into between the [name and address of the Authority] (the "**Authority**") and (the "**Contractor**") for **Construction of Two Lane "Chisopani Traffic Tunnel" of Length 250 m including approaches from Km 67+080 to Km 67+500 on NH-10 in East District of Sikkim State on EPC mode** on Engineering, Procurement, Construction (EPC) basis, and a copy of which is annexed hereto and marked as Annex-A to form part of this TOR.

- In case the bid of Authority's Engineer is invited simultaneously with the bid of EPC project, then the status of bidding of EPC project only to be indicated

- (ii) The TOR shall apply to construction and maintenance of the Project Highway.

2. Definitions and interpretation

- (i) The words and expressions beginning with or in capital letters and not defined herein but defined in the Agreement shall have, unless repugnant to the context, the meaning respectively assigned to them in the Agreement.
- (ii) References to Articles, Clauses and Schedules in this TOR shall, except where the context otherwise requires, be deemed to be references to the Articles, Clauses and Schedules of the Agreement, and references to Paragraphs shall be deemed to be references to Paragraphs of this TOR.
- (iii) The rules of interpretation stated in Article 1 of the Agreement shall apply, mutatis mutandis, to this TOR.

3. General

- (i) The Authority's Engineer shall discharge its duties in a fair, impartial and efficient manner, consistent with the highest standards of professional integrity and Good Industry Practice.
- (ii) The Authority's Engineer shall perform the duties and exercise the authority in accordance with the provisions of this Agreement, but subject to obtaining prior written approval of the Authority before determining:
- (a) any Time Extension;
 - (b) any additional cost to be paid by the Authority to the Contractor;
 - (c) the Termination Payment; or
 - (d) issuance of Completion Certificate or
 - (e) any other matter which is not specified in (a), (b), (c) or (d) above and which creates a financial liability on either Party.
- (iii) The Authority's Engineer shall submit regular periodic reports, at least once every month, to the Authority in respect of its duties and functions under this Agreement. Such reports shall be submitted by the Authority's Engineer within 10 (ten) days of the beginning of every month.

- (iv) The Authority's Engineer shall inform the Contractor of any delegation of its duties and responsibilities to its suitably qualified and experienced personnel; provided, however, that it shall not delegate the authority to refer any matter for the Authority's prior approval in accordance with the provisions of Clause 18.2.
- (v) The Authority's Engineer shall aid and advise the Authority on any proposal for Change of Scope under Article 13.
- (vi) In the event of any disagreement between the Parties regarding the meaning, scope and nature of Good Industry Practice, as set forth in any provision of the Agreement, the Authority's Engineer shall specify such meaning, scope and nature by issuing a reasoned written statement relying on good industry practice and authentic literature.

4. Construction Period

- (i) During the Construction Period, the Authority's Engineer shall review and approve the Drawings furnished by the Contractor along with supporting data, including the geo-technical and hydrological investigations, characteristics of materials from borrow areas and quarry sites, topographical surveys, and the recommendations of the Safety Consultant in accordance with the provisions of Clause 10.1 (vi). The Authority's Engineer shall complete such review and approval and send its observations to the Authority and the Contractor within 15 (fifteen) days of receipt of such Drawings; provided, however that in case of a Major Bridge or Structure, the aforesaid period of 15 (fifteen) days may be extended upto 30 (thirty) days. In particular, such comments shall specify the conformity or otherwise of such Drawings with the Scope of the Project and Specifications and Standards.
- (ii) The Authority's Engineer shall review and approve any revised Drawings sent to it by the Contractor and furnish its comments within 10 (ten) days of receiving such Drawings.
- (iii) The Authority's Engineer shall review and approve the Quality Assurance Plan submitted by the Contractor and shall convey its comments to the Contractor within a period of 21 (twenty one) days stating the modifications, if any, required thereto.
- (iv) The Authority's Engineer shall complete the review and approve of the methodology proposed to be adopted by the Contractor for executing the Works, and convey its comments to the Contractor within a period of 10 (ten) days from the date of receipt of the proposed methodology from the Contractor.
- (v) The Authority's Engineer shall grant written approval to the Contractor, where necessary, for interruption and diversion of the flow of traffic in the existing lane(s) of the Project Highway for purposes of maintenance during the Construction Period in accordance with the provisions of Clause 10.4.
- (vi) The Authority's Engineer shall review the monthly progress report furnished by the Contractor and send its comments thereon to the Authority and the Contractor within 7 (seven) days of receipt of such report.
- (vii) The Authority's Engineer shall inspect the Construction Works and the Project Highway and shall submit a monthly Inspection Report bringing out the results of inspections and the remedial action taken by the Contractor in respect of Defects or deficiencies. In particular, the Authority's Engineer shall include in its Inspection Report, the compliance of the recommendations made by the Safety Consultant.
- (viii) The Authority's Engineer shall conduct the pre-construction review of manufacturer's

test reports and standard samples of manufactured Materials, and such other Materials as the Authority's Engineer may require.

- (ix) For determining that the Works conform to Specifications and Standards, the Authority's Engineer shall require the Contractor to carry out, or cause to be carried out, tests at such time and frequency and in such manner as specified in the Agreement and in accordance with Good Industry Practice for quality assurance. For purposes of this Paragraph 4 (ix), the tests specified in the IRC Special Publication-11 (Handbook of Quality Control for Construction of Roads and Runways) and the Specifications for Road and Bridge Works issued by MORTH (the "Quality Control Manuals") or any modification/substitution thereof shall be deemed to be tests conforming to Good Industry Practice for quality assurance.
- (x) The Authority's Engineer shall test check at least 50 (fifty) percent of the quantity or number of tests prescribed for each category or type of test for quality control by the Contractor.
- (xi) The timing of tests referred to in Paragraph 4 (ix), and the criteria for acceptance/rejection of their results shall be determined by the Authority's Engineer in accordance with the Quality Control Manuals. The tests shall be undertaken on a random sample basis and shall be in addition to, and independent of, the tests that may be carried out by the Contractor for its own quality assurance in accordance with Good Industry Practice.
- (xii) In the event that results of any tests conducted under Clause 11.10 establish any Defects or deficiencies in the Works, the Authority's Engineer shall require the Contractor to carry out remedial measures.
- (xiii) The Authority's Engineer may instruct the Contractor to execute any work which is urgently required for the safety of the Project Highway, whether because of an accident, unforeseeable event or otherwise; provided that in case of any work required on account of a Force Majeure Event, the provisions of Clause 21.6 shall apply.
- (xiv) In the event that the Contractor fails to achieve any of the Project Milestones, the Authority's Engineer shall undertake a review of the progress of construction and identify potential delays, if any. If the Authority's Engineer shall determine that completion of the Project Highway is not feasible within the time specified in the Agreement, it shall require the Contractor to indicate within 15 (fifteen) days the steps proposed to be taken to expedite progress, and the period within which the Project Completion Date shall be achieved. Upon receipt of a report from the Contractor, the Authority's Engineer shall review the same and send its comments to the Authority and the Contractor forthwith.
- (xv) The Authority's Engineer shall obtain from the Contractor a copy of all the Contractor's quality control records and documents before the Completion Certificate is issued pursuant to Clause 12.2.
- (xvi) Authority's Engineer may recommend to the Authority suspension of the whole or part of the Works if the work threatens the safety of the Users and pedestrians. After the Contractor has carried out remedial measure, the Authority's Engineer shall inspect such remedial measures forthwith and make a report to the Authority recommending whether or not the suspension hereunder may be revoked.
- (xvii) In the event that the Contractor carries out any remedial measures to secure the safety of suspended works and Users, and requires the Authority's Engineer to inspect such works, the Authority's Engineer shall inspect the suspended works within 3 (three) days

of receiving such notice, and make a report to the Authority forthwith, recommending whether or not such suspension may be revoked by the Authority.

- (xviii) The Authority's Engineer shall carry out, or cause to be carried out, all the Tests specified in Schedule-K and issue a Completion Certificate, as the case may be. For carrying out its functions under this Paragraph 4 (xviii) and all matters incidental thereto, the Authority's Engineer shall act under and in accordance with the provisions of Article 12 and Schedule-K.

5. Maintenance Period

- (i) The Authority's Engineer shall aid and advise the Contractor in the preparation of its monthly Maintenance Programme and for this purpose carry out a joint monthly inspection with the Contractor.
- (ii) The Authority's Engineer shall undertake regular inspections, at least once every month, to evaluate compliance with the Maintenance Requirements and submit a Maintenance Inspection Report to the Authority and the Contractor.
- (iii) The Authority's Engineer shall specify the tests, if any, that the Contractor shall carry out, or cause to be carried out, for the purpose of determining that the Project Highway is in conformity with the Maintenance Requirements. It shall monitor and review the results of such tests and the remedial measures, if any, taken by the Contractor in this behalf.
- (iv) In respect of any defect or deficiency referred to in Paragraph 3 of Schedule- E, the Authority's Engineer shall, in conformity with Good Industry Practice, specify the permissible limit of deviation or deterioration with reference to the Specifications and Standards and shall also specify the time limit for repair or rectification of any deviation or deterioration beyond the permissible limit.
- (v) The Authority's Engineer shall examine the request of the Contractor for closure of any lane(s) of the Project Highway for undertaking maintenance/repair thereof, and shall grant permission with such modifications, as it may deem necessary, within 5 (five) days of receiving a request from the Contractor. Upon expiry of the permitted period of closure, the Authority's Engineer shall monitor the reopening of such lane(s), and in case of delay, determine the Damages payable by the Contractor to the Authority under Clause 14.5.

6. Determination of costs and time

- (i) The Authority's Engineer shall determine the costs, and/or their reasonableness, that are required to be determined by it under the Agreement.
- (ii) The Authority's Engineer shall determine the period of Time Extension that is required to be determined by it under the Agreement.
- (iii) The Authority's Engineer shall consult each Party in every case of determination in accordance with the provisions of Clause 18.5.

7. Payments

- (i) The Authority's Engineer shall withhold payments for the affected works for which the Contractor fails to revise and resubmit the Drawings to the Authority's Engineer in accordance with the provisions of Clause 10.2 (iv) (d).
- (ii) Authority's Engineer shall -

- (a) within 10 (ten) days of receipt of the Stage Payment Statement from the Contractor pursuant to Clause 19.4, determine the amount due to the Contractor and recommend the release of 90 (ninety) percent of the amount so determined as part payment, pending issue of the Interim Payment Certificate; and
- (b) within 15 (fifteen) days of the receipt of the Stage Payment Statement referred to in Clause 19.4, deliver to the Authority and the Contractor an Interim Payment Certificate certifying the amount due and payable to the Contractor, after adjustments in accordance with the provisions of Clause 19.10.
- (iii) The Authority's Engineer shall, within 15 (fifteen) days of receipt of the Monthly Maintenance Statement from the Contractor pursuant to Clause 19.6, verify the Contractor's monthly statement and certify the amount to be paid to the Contractor in accordance with the provisions of the Agreement.
- (iv) The Authority's Engineer shall certify final payment within 30 (thirty) days of the receipt of the final payment statement of Maintenance in accordance with the provisions of Clause 19.16.

8. Other duties and functions

The Authority's Engineer shall perform all other duties and functions as specified in the Agreement.

9. Miscellaneous

- (i) A copy of all communications, comments, instructions, Drawings or Documents sent by the Authority's Engineer to the Contractor pursuant to this TOR, and a copy of all the test results with comments of the Authority's Engineer thereon, shall be furnished by the Authority's Engineer to the Authority forthwith.
- (ii) The Authority's Engineer shall retain at least one copy each of all Drawings and Documents received by it, including 'as-built' Drawings, and keep them in its safe custody.
- (iii) Within 90 (ninety) days of the Project Completion Date, the Authority's Engineer shall obtain a complete set of as-built Drawings, in 2 (two) hard copies and in micro film form or in such other medium as may be acceptable to the Authority, reflecting the Project Highway as actually designed, engineered and constructed, including an as-built survey illustrating the layout of the Project Highway and setback lines, if any, of the buildings and structures forming part of Project Facilities; and shall hand them over to the Authority against receipt thereof.
- (iv) The Authority's Engineer, if called upon by the Authority or the Contractor or both, shall mediate and assist the Parties in arriving at an amicable settlement of any Dispute between the Parties.
- (v) The Authority's Engineer shall inform the Authority and the Contractor of any event of Contractor's Default within one week of its occurrence.

Schedule - O

(See Clauses 19.4 (i), 19.6 (i), and 19.8 (i))

Forms of Payment Statements

1. Stage Payment Statement for Works

The Stage Payment Statement for Works shall state:

- (a) the estimated amount for the Works executed in accordance with Clause 19.3 (i) subsequent to the last claim;
- (b) amounts reflecting adjustments in price for the aforesaid claim;
- (c) the estimated amount of each Change of Scope Order executed subsequent to the last claim;
- (d) amounts reflecting adjustment in price, if any, for (c) above in accordance with the provisions of Clause 13.2 (iii) (a);
- (e) total of (a), (b), (c) and (d) above;
- (f) Deductions:
 - i. Any amount to be deducted in accordance with the provisions of the Agreement except taxes;
 - ii. Any amount towards deduction of taxes; and
 - iii. Total of (i) and (ii) above.
- (g) Net claim: (e) - (f) (iii);
- (h) The amounts received by the Contractor upto the last claim:
 - iv. For the Works executed (excluding Change of Scope orders);
 - v. For Change of Scope Orders, and
 - vi. Taxes deducted

2. Monthly Maintenance Payment Statement

The monthly Statement for Maintenance Payment shall state:

- (a) the monthly payment admissible in accordance with the provisions of the Agreement;
- (b) the deductions for maintenance work not done;
- (c) net payment for maintenance due, (a) minus (b);
- (d) amounts reflecting adjustments in price under Clause 19.12; and
- (e) amount towards deduction of taxes

3. Contractor's claim for Damages

Note: The Contractor shall submit its claims in a form acceptable to the Authority.

Schedule - P

(See Clause 20.1)

Insurance

1. Insurance during Construction Period

- (i) The Contractor shall effect and maintain at its own cost, from the Appointed Date till the date of issue of the Completion Certificate, the following insurances for any loss or damage occurring on account of Non Political Event of Force Majeure, malicious act, accidental damage, explosion, fire and terrorism:
- (a) insurance of Works, Plant and Materials and an additional sum of [15 (fifteen)] per cent of such replacement cost to cover any additional costs of and incidental to the rectification of loss or damage including professional fees and the cost of demolishing and removing any part of the Works and of removing debris of whatsoever nature; and
 - (b) insurance for the Contractor's equipment and Documents brought onto the Site by the Contractor, for a sum sufficient to provide for their replacement at the Site.
- (ii) The insurance under sub para (a) and (b) of paragraph 1(i) above shall cover the Authority and the Contractor against all loss or damage from any cause arising under paragraph 1.1 other than risks which are not insurable at commercial terms.

2. Insurance for Contractor's Defects Liability

The Contractor shall effect and maintain insurance cover of not less than 15% of the Contract Price for the Works from the date of issue of the Completion Certificate until the end of the Defects Liability Period for any loss or damage for which the Contractor is liable and which arises from a cause occurring prior to the issue of the Completion Certificate. The Contractor shall also maintain other insurances for maximum sums as may be required under the Applicable Laws and in accordance with Good Industry Practice.

3. Insurance against injury to persons and damage to property

- (i) The Contractor shall insure against its liability for any loss, damage, death or bodily injury, or damage to any property (except things insured under Paragraphs 1 and 2 of this Schedule or to any person (except persons insured under Clause 20.9), which may arise out of the Contractor's performance of this Agreement. This insurance shall be for a limit per occurrence of not less than the amount stated below with no limit on the number of occurrences.

The insurance cover shall be not less than: Rs. [*****]

- (ii) The insurance shall be extended to cover liability for all loss and damage to the Authority's property arising out of the Contractor's performance of this Agreement excluding:
- (a) the Authority's right to have the construction works executed on, over, under, in or through any land, and to occupy this land for the Works; and
 - (b) damage which is an unavoidable result of the Contractor's obligations to execute the Works.

4. Insurance to be in joint names

The insurance under paragraphs 1 to 3 above shall be in the joint names of the Contractor and the Authority.

Schedule-Q

(See Clause 14.10)

Tests on Completion of Maintenance Period

1. Riding Quality test:

Riding quality test: Riding quality of each lane of the carriageway shall be checked with the help of a calibrated bump integrator and the maximum permissible roughness for purposes of this Test shall be [2,200 (two thousand and two hundred only)] mm for each kilometre.

2. Visual and physical test:

The Authority's Engineer shall conduct a visual and physical check of construction to determine that all works and equipment forming part thereof conform to the provisions of this Agreement. The physical tests shall include measurement of cracking, rutting, stripping and potholes and shall be as per the requirement of maintenance mentioned in Schedule-E.

Schedule-R

(See Clause 14.10)

Taking Over Certificate

I,..... (Name and designation of the Authority's Representative) under and in accordance with the Agreement dated..... (the "**Agreement**"), for [construction of the****section (km ** to km **) of

****] (the "**Project Highway**") on Engineering, Procurement and Construction (EPC) basis

Through (Name of Contractor), hereby certify that the Tests on completion of Maintenance Period in accordance with Article 14 of the Agreement have been successfully undertaken to determine compliance of the Project Highway with the provisions of the Agreement and I hereby certify that the Authority has taken over the Project highway from the Contractor on this day

SIGNED, SEALED AND DELIVERED

(Signature)

(Name and designation of Authority's Representative)

(Address)

*******END OF THE DOCUMENT*******