

**NATIONAL HIGHWAYS & INFRASTRUCTURE
DEVELOPMENT CORPORATION LTD.
(Ministry of Road, Transport & Highways)
Government of India**

TECHNICAL SCHEDULES

Construction and upgradation of existing road to 2-lane with Paved shoulder from km. 20.340 (Rongli Bazzar) to km. 26.588 (Rongli Bypass End) and upgradation of existing road at km 20.600 & km 26.400 for length of 0.520 km & 0.554 km of Rhenok – Menla spur (NH-717B) Package-II A on EPC Basis under SARDP-NE Phase ‘A’ in the State of Sikkim

**Engineering, Procurement & Construction
(EPC) Mode**

**BID DOCUMENT (Schedule)
November -2020**



**National Highways & Infrastructure
Development Corporation Ltd.
(A Government of India Undertaking)**

SCHEDULE - A
(See Clauses 2.1 and 8.1)

SITE OF THE PROJECT

1. The Site

- 1.1 Site of the Rongli Bazaar – Rongli Bypass End Section of NH-717B Project Highway shall include the land, buildings, structures and road works as described in Annex-I of this Schedule-A.
- 1.2 The dates of handing over the Right of Way to the Contractor are specified in Annex-II of this Schedule-A.
- 1.3 An inventory of the Site including the land, buildings, structures, road works, trees and any other immovable property on, or attached to, the Site shall be prepared jointly by the Authority Representative and the Contractor, and such inventory shall form part of the memorandum referred to in Clause 8.2.(i) of this Agreement.
- 1.4 The alignment plans of the Project Highway are specified in Annex-III. In the case of sections where no modification in the existing alignment of the Project Highway is contemplated, the alignment plan has not been provided. Alignment plans have only been given for sections where the existing alignment is proposed to be upgraded. The proposed profile of the Project Highways shall be followed by the contractor with minimum FRL as indicated in the alignment plan. The Contractor, however, improve/upgrade the Road Profile as indicated in Annex-III based on site/design requirement.
- 1.5 The status of the environment clearances obtained or awaited is given in Annex IV.

**Annex – I
(Schedule – A)
Site**

[Note: Through suitable drawings and description in words, the land, buildings, structures and road works comprising the Site shall be specified briefly but precisely in this Annex-I. All the chainages/ location referred to in Annex-I to Schedule-A shall be existing chainages.]

1. Site

The Site of the Two-Lane Project Highway comprises the section of National Highway -717B commencing from Km 0+000 to Km 4+565 i.e. from Rongli Bazzar to Rongli Bypass End, section of Rongli to Chochenpheri in the State of Sikkim. The land, carriageway and structures comprising the Site are described below.

2. Land

The Site of the Project Highway comprises the land (sum total of land already in possession and land to be possessed) described below:

Sr. No.	Chainage (km)		ROW (Meter)
	From	To	
1	0+000	4+565	14-16

3. Carriageway

The width of carriageway varies from 3.75 m to 5.00 m as under. The type of the existing pavement is Flexible.

Sr. No.	Carriageway					
	Single Lane		Two Lane		Four Lane	
	From	To	From	To	From	To
1	0+000	4+565	Nil		Nil	

4. Major Bridges

The Site includes the following Major Bridges

Sr. No.	Existing Chainage (km)	Type of Structure			No. of Spans with span length (m)	Width (m)	Remarks
		Foundation	Sub-structure	Super structure			
Nil							

5. Road over-bridges (ROB)/ Road under-bridges (RUB)

The Site includes the following ROB/RUB:

Sr. No.	Existing Chainage (km)	Type of Structure		No. of Spans with Span length (m)	Width (m)	ROB/ RUB
		Foundation	Super Structure			
NIL						

Construction and upgradation of existing road to 2-lane with Paved shoulder from km. 20.340 (Rongli Bazzar) to km. 26.588 (Rongli Bypass End) and upgradation of existing road at km 20.600 & km 26.400 for length of 0.520 km & 0.554 km of Rhenok – Menla spur (NH-717B) Package-II A on EPC Basis under SARDP-NE Phase ‘A’ in the State of Sikkim.

6. Grade separators

The Site includes the following grade separators:

Sr. No.	Existing Chainage (km)	Type of Structure		No. of Spans with Span length (m)	Width (m)	ROB/ RUB
		Foundation	Super Structure			
NIL						

7. Minor bridges

The Site includes the following minor bridges:

Sr. No.	Chainage (km)	Type of Structure		No. of Spans with span length (m)	Width (m)
		Foundation	Superstructure		
Nil					

8. Railway level crossings

The Site includes the following railway level crossings:

Sr. No.	Existing Chainage (km)	Remarks
NIL		

9. Underpasses (vehicular, Non-vehicular)

The Site includes the following underpasses:

Sr. No.	Existing Chainage (km)	Type of Structure	No. of Spans with Span length (m)	Width (m)
Nil				

10. Culverts and causeway:

The Site has the following exiting culverts:

Sl. No.	Existing Chainage (km)	Existing Size	Type	Remarks
1	0+000	1x0.7m	RCC Slab	Reconstruction
2	0+200	-	Causeway	Reconstruction
3	0+335	1x1.25m	RCC Slab	Reconstruction
4	0+581	1x1.1m	RCC Slab	Reconstruction
5	0+749	1x1.1m	RCC Slab	Retain
6	0+909	1x1.0m	RCC Slab	Retain
7	0+956	1x1.50m	RCC Slab	Retain
8	1+052	1x1.1m	RCC Slab	Retain
9	1+193	1x1.1m	RCC Slab	Retain
10	1+512	1x1.0m	RCC Slab	Retain
11	1+722	1x1.1m	RCC Slab	Retain
12	1+878	1x0.05m	RCC Slab	Retain
13	2+074	1x1.2m	RCC Slab	Retain
14	2+191	1x1.3m	RCC Slab	Retain
15	2+382	1x0.7m	RCC Slab	Retain
16	2+490	1x0.7m	RCC Slab	Retain

Sl. No.	Existing Chainage (km)	Existing Size	Type	Remarks
17	2+518	1x1.2m	RCC Slab	Retain
18	2+740	1x0.7m	RCC Slab	Retain
19	2+101	1x0.30	RCC Slab	Retain
20	3+100	1x8.6m	RCC Slab	Retain
21	3+875	1x0.6m	RCC Slab	Reconstruction
22	4+000	1x0.6m	RCC Slab	Reconstruction

11. Bus Stops

The details of bus Stops on the Site are as follows:

Sl. No.	Existing Chainage	Sides
1	0+205	Both sides
2	0+605	Both sides
3	1+600	Both sides
4	3+445	Both sides
5	4+375	Both sides

12. Truck Lay bays

The details of truck lay bays are as follows:

Sr. No.	Existing Chainage (Km)	Length (m)	LHS	RHS
Nil				

13. Road side drains

The details of the roadside drains are as follows:

Sr. No.	Location		Type	
	From km	To km	Masonry/cc (Pucca)	Earthen (Kutchha)
1	0+100	0+550	Pucca	-
2	1+050	1+080	Pucca	-
3	2+100	2+160	Pucca	-
4	2+210	2+230	Pucca	-
5	2+350	2+420	Pucca	-
6	2+740	2+760	Pucca	-
7	3+250	3+360	Pucca	-
8	3+750	3+800	Pucca	-
9	4+090	4+565	Pucca	-

14. Major junctions

The detail of major junction is as follows:

Sr. No.	Existing Chainage	Type	Link	Direction	Remarks
Nil					

15. Minor junctions

The details of the minor junctions are as follows:-

SL. No.	Existing Chainage	Type of intersection	Direction	Type of Road	Going to
			Left/Right	E/BT/CC	
1	0+180	Y	Left	BT	Mela Ground
2	0+570	Y	Right	BT	Rongliphc
3	3+420	Y	Right	E	
4	4+400		Left	BT	Chujachen Village

16. Bypasses

The details of the existing road sections proposed to be bypassed are as follows:

Sr. No.	Name of Bypass (Town)	Existing Chainage (Km)		Length (Km)	Carriageway	
		From	To		Width (m)	Type
Nil						

17. Other structures

Nil

Annex - II
(Schedule-A)

**Dates for providing Right of Way of
construction Zone**

The dates on which the Authority shall provide Right of Way of Construction Zone to the Contractor on different stretches of the Site are stated below:

Sr. No.	From km To km	Length (Km)	Proposed ROW (m)	Date of providing ROW*
1	2	3	4	5
Full Right of Way (full width)	Excluding Bypass & Realignment, Bus bays, Truck Lay Bye	0.260	24	At appointed date
	Junction improvement at Km 20+600 & 26+410	1.074	18	Existing ROW
Balance Right of Way (Width)	Realignment	-	-	Within 90 days of declaration of appointed date
	Bypass	5.988	24	
	Truck Lay Bye	-	-	

*The dates specified herein shall in no case be beyond 150 (one hundred and fifty) days after the Appointed Date.

Note: Extra length of 0.520 km at km 20.600 and 0.554 km at km 26.400 will be developed in available ROW (18m). It should be verified with concerned department before construction.

Annex - III
(Schedule-A)

Alignment Plans

The existing alignment of the Project Highway shall be modified in the following sections as per the alignment plan indicated below:

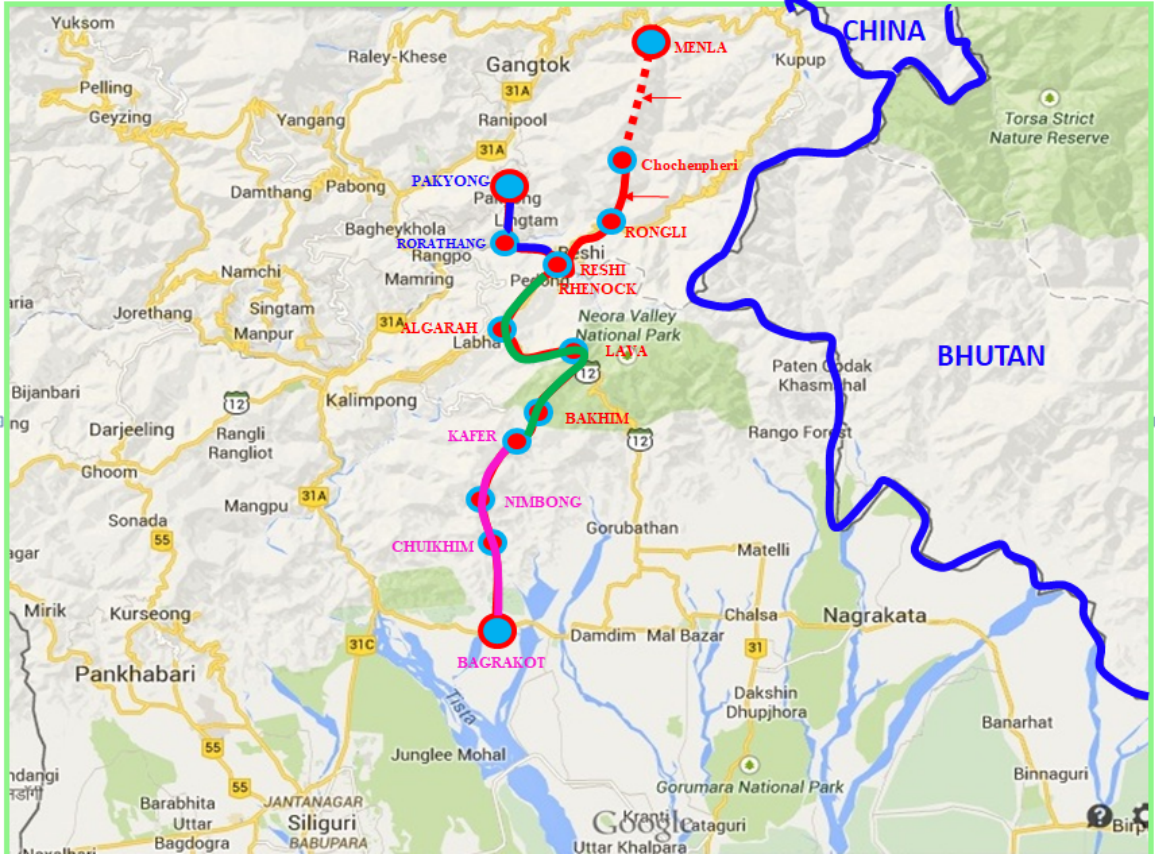

An alignment plan is given in soft copy.

The alignment of the Project Highway is enclosed in alignment plan. Finished road level indicated in the alignment plan shall be followed by the contractor as minimum FRL. In any case, the finished road level of the project highway shall not be less than those indicated in the alignment plan. The contractor shall, however, improve/upgrade the Road profile as indicated in Annex-III based on site/design requirement.

Traffic Signage plan of the Project Highway showing numbers & location of traffic signs is enclosed. The contractor shall, however, improve/upgrade upon the traffic signage plan as indicated in Annex-III based on site/design requirement as per IRC: SP: 99 & IRC: 67.

Construction and upgradation of existing road to 2-lane with Paved shoulder from km. 20.340 (Rongli Bazaar) to km. 26.588 (Rongli Bypass End) and upgradation of existing road at km 20.600 & km 26.400 for length of 0.520 km & 0.554 km of Rhenok – Menla spur (NH-717B) Package-II A on EPC Basis under SARDP-NE Phase ‘A’ in the State of Sikkim.

Annex - IV
(Schedule-A)

Environment Clearances

The following clearances have been obtained:

Sr. No.	Clearances	Present Status
1	Environment clearance	Not Required
2	Forest Clearance	Required
3	Wildlife Approval	Not Required

SCHEDULE - B
(See Clause 2.1)

Development of the Project Highway

1 Development of the Project Highway

Development of the Project Highway shall include design and construction of the Project Highway as described in this Schedule-B and in Schedule-C.

2 Two Lane with Paved shoulder

Two laning shall be done to strengthening of the existing lane along with construction of paved shoulders as described in Annex-I of this Schedule-B and Annex-I of Schedule-C.

3 Specifications and Standards

The Project Highway shall be designed and constructed in conformity with the Specifications and Standards specified in Annex-I of Schedule-D.

Annex - I
(Schedule-B)

1. Description of Two Lane with Paved Shoulder

The Site of the Two-Lane Project Highway comprises the section of National Highway -717B commencing from Rongli Bazaar at km 20+340 and ends at Rongli Bypass End at km 26+588 and upgradation of existing road at km 20.600 & km 26.400 for length of 0.520 km & 0.554 km in the section of Rongli to Chochenpheri (Length 7.322 km) in the State of Sikkim. The land, carriageway and structures comprising the Site are described below.

1.1 WIDENING OF THE EXISTING HIGHWAY

The Project Highway shall follow the existing alignment unless otherwise specified by the Authority and shown in the alignment plans specified in Annexure III of Schedule-A. Geometric deficiencies, if any, in the existing horizontal and vertical profiles shall be corrected as per the prescribed standards for plain/rolling terrain to the extent land is available.

1.2 WIDTH OF CARRIAGEWAY

Two Lanning with paved shoulder shall be undertaken. The paved carriageway shall be 7m wide with 1.5m paved shoulder on both sides in accordance with the typical cross section drawings and as per IRC:SP:73-2018. On Horizontal Curves, roadways width should be increased to provide for extra widening at Curves as per Cl. 6.8.5 of IRC:SP:48-1998.

Provided that in the built-up areas the width of the carriageway shall be as specified in the following table:

Sl. No	Built-up Stretch (Township)	Start chainage	End chainage	Length (Km)	Width (m)	Typical Cross Section No.
Nil						

1.2.1 Except as otherwise provided in this Agreement, the width of the paved carriageway and cross-sectional features shall conform to paragraph 1.1 above.

2. GEOMETRIC DESIGN AND GENERAL FEATURES

2.1 General

Geometric design and general features of the Project Highway shall be in accordance with Section 2 of the Manual.

2.2 Design speed

The design speed shall be minimum design speed of 20/40 km per hr. for Mountainous and Steep terrain.

2.3 Improvement of the existing road geometrics

2.3.1 Details of Bypass

Sr. No.	Existing Chainage		Length (km)	Design Chainage		Length (km)	Remarks
	From	To		From	To		
1	0+200	4+565	4.365	20+600	26+588	5.988	Rongli bypass

Construction and upgradation of existing road to 2-lane with Paved shoulder from km. 20.340 (Rongli Bazaar) to km. 26.588 (Rongli Bypass End) and upgradation of existing road at km 20.600 & km 26.400 for length of 0.520 km & 0.554 km of Rhenok – Menla spur (NH-717B) Package-II A on EPC Basis under SARDP-NE Phase ‘A’ in the State of Sikkim.

2.3.2 Realignment :

S.No	Proposed Chainage		Length	Type of Alignment	TCS
	From	To			
Nil					

2.4 Right of Way

Details of the Right of Way are given in Annex II of Schedule-A.

2.5 Type of shoulders

In built-up sections, 1.5m footpath cum drain and 2x1.5m paved shoulders shall be provided in the following stretches:

Sl. No.	Design Chainage		Length (m)	Fully Paved Shoulder/Foothpath	Reference to Cross Section (TCS)
	From	To			
Nil					

- (a) In open country, (Paved shoulders of 1.5 m width shall be provided and 1.0m earthen shoulder shall be provided on valley side as per IRC:SP-73-2018).

Sl. No	Proposed Chainage		Length (Km)	Fully Paved Shoulder/Foothpath
1.	20.340	20.490	0.150	Paved shoulder
2.	20.490	20.600	0.110	Paved shoulder
3.	20.600	20.660	0.060	Paved shoulder
4.	20.660	20.880	0.220	Paved shoulder
5.	20.980	21.260	0.280	Paved shoulder
6.	21.820	22.790	0.970	Paved shoulder
7.	22.790	23.470	0.680	Paved shoulder
8.	23.750	24.140	0.390	Paved shoulder
9.	24.560	24.660	0.100	Paved shoulder
10.	24.840	24.930	0.090	Paved shoulder
11.	24.970	25.450	0.480	Paved shoulder
12.	25.450	25.630	0.180	Paved shoulder
13.	25.870	26.090	0.220	Paved shoulder
14.	26.450	26.588	0.138	Paved shoulder

- (b) Design and specifications of paved shoulders and granular material shall conform to the requirements specified in paragraphs 5.9.9 and 5.9.10 of the Manual.

2.6 Lateral and vertical clearances at underpasses

2.6.1 Lateral and vertical clearances at underpasses and provision of guard rails/crash barriers shall be as per paragraph 2.11 of 2-laning Manual.

2.6.2 Lateral clearance: The width of the opening at the underpasses shall be as follows:

Sr. No.	Location Chainage (From km to km)	Span / Opening (m)	Remarks
Nil			

Vertical clearance: Vertical Clearance at underpasses/Flyovers shall not be less than 5.5 m and for Cattle underpass shall not be less than 4.5 m.

2.7 Lateral and vertical clearances at overpasses

2.7.1 Lateral and vertical clearances at overpasses shall be as per paragraph 2.11 of the 2-laning Manual.

2.7.2 Lateral clearance: The width of the opening at the overpasses shall be as follows:

Sr. No.	Design Chainage (Km)	Span / Opening (m)	Remarks
Nil			

2.7.3 **Vertical clearance:** A minimum 5.5 m vertical clearance shall be provided at all points of the carriageway of the project highway.

2.8 Service roads:

Service roads shall be constructed at the locations and for the lengths indicated below:

Sr. No.	Location of Service road (from km to km)	Right hand side (RHS)/ Left hand side (LHS)/ or Both sides	Length (km) of Service road
Nil			

Details of Slip Road:

Sr. No.	Existing Chainage		Design Chainage		Right Hand side(RHS) or Left Hand side (LHS) or Both side	Length Km of Service Road
	From	To	From	To		
NIL						

2.9 Grade separated structures:

2.9.1 Grade separated structures shall be provided as per paragraph 2.14 of the 2-laning Manual. The requisite particulars are given below:

[Refer to paragraphs 2.14.1 of the Manual and provide details]

Sr. No.	Location of structure (Existing)	Location of structure (Design)	Length (m)	Number & length of Spans (m)	Approach Gradient	Remarks, if any
NIL						

2.9.2 In the case of grade separated structures, the type of structure and the level of the Project Highway and the cross roads shall be as follows: [Refer to paragraphs 2.14.2 of the Manual and specify the type of vehicular under pass/ overpass structure and whether the cross road is to be carried at the existing level, raised or lowered]

Sr. No.	Location (Design Chainage)	Location (Design Chainage)	Type of Structure Length	Cross road at		
				Existing level	Raised Level	Lowered Level
NIL						

2.10 Cattle and pedestrian underpass /overpass

Cattle and pedestrian underpass/ overpass shall be constructed as follows:

[Refer to paragraphs 2.13.3 of the Manual and specify the requirements of Cattle and pedestrian underpass/ overpass].

2.11 Typical cross-sections of the Project Highway

Indicative typical cross section of the Project highway shall be Fig. 2.8 to 2.9 of the manual (IRC: SP: 73-2018).

Summary of TCS

S.No	TCS Description	TCS Type	Length (km)
1.	Two lane with Paved shoulder Concentric (Both Side Valley section)	I	0.150
2.	Two lane with Paved shoulder Concentric (Both Side Hill section)	II	0.110
3.	Two lane with Paved shoulder New alignment (Both Side Hill section)	III	1.210
4.	Two lane including climbing lane with one side Paved shoulder New alignment (Both Side Hill section)	IIIA	1.180
5.	Two lane with Paved shoulder New alignment (one Side Hill, one side Valley section)	IV	1.038
6.	Two lane including climbing lane with one side Paved shoulder New alignment (one Side Hill, one side Valley section)	IVA	0.380
7.	Elevated Structure (including box abutment length)	V	2.180
8.	Intermediate lane without paved shoulder concentric widening Both side hill	TCS-VI	0.520
9.	Intermediate lane without paved shoulder concentric widening Both side Valley	TCS-VII	0.554
Total			7.322

Indicative Chainage with applicable Typical Cross section :

Sl. No	Proposed Chainage		Length (Km)	Type of alignment	TCS
	From (Km)	To (Km)			
1	20.340	20.490	0.150	Two lane with Paved shoulder Concentric (Both Side Valley section)	I
2	20.490	20.600	0.110	Two lane with Paved shoulder Concentric (Both Side Hill section)	II
3	20.600	20.660	0.060	Two lane with Paved shoulder New alignment (Both Side Hill section)	III

Construction and upgradation of existing road to 2-lane with Paved shoulder from km. 20.340 (Rongli Bazaar) to km. 26.588 (Rongli Bypass End) and upgradation of existing road at km 20.600 & km 26.400 for length of 0.520 km & 0.554 km of Rhenok – Menla spur (NH-717B) Package-II A on EPC Basis under SARDP-NE Phase ‘A’ in the State of Sikkim.

Sl. No	Proposed Chainage		Length (Km)	Type of alignment	TCS
	From (Km)	To (Km)			
4	20.660	20.880	0.220	Two lane with Paved shoulder New alignment (one Side Hill, one side Valley section)	IV
5	20.880	20.980	0.100	Elevated Structure (including box abutment length)	V
6	20.980	21.260	0.280	Two lane including climbing lane with one side Paved shoulder New alignment (one Side Hill, one side Valley section)	IVA
7	21.260	21.820	0.560	Elevated Structure (including box abutment length)	V
8	21.820	22.790	0.970	Two lane with Paved shoulder New alignment (Both Side Hill section)	III
9	22.790	23.470	0.680	Two lane with Paved shoulder New alignment (one Side Hill, one side Valley section)	IV
10	23.470	23.750	0.280	Elevated Structure (including box abutment length)	V
11	23.750	24.140	0.390	Two lane including climbing lane with one side Paved shoulder New alignment (Both Side Hill section)	IIIA
12	24.140	24.560	0.420	Elevated Structure (including box abutment length)	V
13	24.560	24.660	0.100	Two lane including climbing lane with one side Paved shoulder New alignment (one Side Hill, one side Valley section)	IVA
14	24.660	24.840	0.180	Elevated Structure (including box abutment length)	V
15	24.840	24.930	0.090	Two lane including climbing lane with one side Paved shoulder New alignment (Both Side Hill section)	IIIA
16	24.930	24.970	0.040	Elevated Structure (including box abutment length)	V
17	24.970	25.450	0.480	Two lane including climbing lane with one side Paved shoulder New alignment (Both Side Hill section)	IIIA
18	25.450	25.630	0.180	Two lane with Paved shoulder New alignment (Both Side Hill section)	III
18	25.630	25.870	0.240	Elevated Structure (including box abutment length)	V
19	25.870	26.090	0.220	Two lane including climbing lane with one side Paved shoulder New alignment (Both Side Hill section)	IIIA
20	26.090	26.450	0.360	Elevated Structure (including box abutment length)	V
21	26.450	26.588	0.138	Two lane with Paved shoulder New alignment (one Side Hill, one side Valley section)	IV
Upgradation of the existing road at chainage 20+600 & 26+410 to match the junction level as per proposed alignment					
22	0.000	0.520	0.520	Intermediate lane without paved shoulder concentric widening Both side hill	TCS-VI
23	0.000	0.554	0.554	Intermediate lane without paved shoulder concentric widening Both side Valley	TCS-VII
Total Length			7.322		

Construction and upgradation of existing road to 2-lane with Paved shoulder from km. 20.340 (Rongli Bazaar) to km. 26.588 (Rongli Bypass End) and upgradation of existing road at km 20.600 & km 26.400 for length of 0.520 km & 0.554 km of Rhenok – Menla spur (NH-717B) Package-II A on EPC Basis under SARDP-NE Phase ‘A’ in the State of Sikkim.

Sl. No	Proposed Chainage		Length (Km)	Type of alignment	TCS
	From (Km)	To (Km)			
	(km)				

3. INTERSECTIONS AND GRADE SEPARATORS

All intersections and grade separators shall be as per Section 3 of the Manual. Existing intersections which are deficient shall be improved to the prescribed standards. Properly designed intersections shall be provided at the locations and of the types and features given in the tables below:-

3.1 At-Grade Intersection:

3.1.1 Major intersections

At grade major intersections shall be improved at intersecting roads with the Project highway is given below:-

Sr. No.	Existing Chainage	Proposed Chainage	Type	Link	Direction	Remarks
1	0+200	20+600	Y	Towards Rongli town	RHS	BT Road
2	4+400	26+400	Y	Towards Rongli town	RHS	BT Road

3.1.2 Minor Intersections

At grade minor intersections shall be improved at intersecting roads with the Project highway is given below:

Sl. No.	Design Chainage	Type of intersection	Direction	Type of Road
			(Left/Right)	(E/BT/CC)
Nil				

4. Road Embankment and Cut Section

(i) Widening and improvement of the existing road embankment/cuttings and construction of new road embankment/ cuttings shall conform to the Specifications and Standards given in section 4 of the Manual and the specified cross sectional details. Deficiencies in the plan and profile of the existing road shall be corrected.

(ii) Raising of the existing road:

The existing road shall be raised in the following sections:

Sl. No	Proposed Chainage		Length (Km)	Type of alignment	TCS
	From (Km)	To (Km)			
1.	20.340	20.490	0.150	Two lane with Paved shoulder Conncentric (Both Side Valley section)	I
2.	20.490	20.600	0.110	Two lane with Paved shoulder Conncentric (Both Side Hill section)	II

Construction and upgradation of existing road to 2-lane with Paved shoulder from km. 20.340 (Rongli Bazaar) to km. 26.588 (Rongli Bypass End) and upgradation of existing road at km 20.600 & km 26.400 for length of 0.520 km & 0.554 km of Rhenok – Menla spur (NH-717B) Package-II A on EPC Basis under SARDP-NE Phase ‘A’ in the State of Sikkim.

5. PAVEMENT DESIGN

Pavement design shall be carried out for a design life of 20 years considering 25 MSA as per IRC 37-2018.

Note: 1. The minimum CBR of subgrade is 10%.

5.1 Type of pavement

Flexible pavement shall be adopted for the Main carriageway in the open country and rigid pavement in the built up section as per the details given below:

Crust composition (Minimum) for flexible pavement:

BC	40 mm
BSM	110 mm
CTSB	200 mm
SUBGRADE	500 mm

Crust composition (Minimum) for Rigid pavement:

PQC	300 mm
DLC	150 mm
GSB	150 mm
SUBGRADE	500 mm

5.2 Design requirements

5.2.1 Design Period and strategy

Flexible Pavement shall be designed.

5.2.2 Design Traffic

Notwithstanding anything to the contrary contained in this Agreement or the Manual, the Contractor shall design the pavement for design traffic of 25 million standard axles.

5.3 Reconstruction of stretches

The stretches mention in clause 4 (ii) of the same document shows the table of the existing road that shall be reconstructed.

6. ROAD SIDE DRAINAGE

Drainage system including surface and subsurface drains for the Project Highway shall be provided as per Section 6 of the Manual.

Lined Drain Location:

S.No	Description	Side	Length (km)	Total Length
1.	Two lane with Paved shoulder Conncentric (Both Side Hill section)	2	0.110	0.220
2.	Two lane with Paved shoulder New alignment (Both Side Hill section)	2	1.210	2.420
3.	Two lane including climbing lane with one side Paved shoulder New alignment (Both Side Hill section)	2	1.180	2.360

Construction and upgradation of existing road to 2-lane with Paved shoulder from km. 20.340 (Rongli Bazzar) to km. 26.588 (Rongli Bypass End) and upgradation of existing road at km 20.600 & km 26.400 for length of 0.520 km & 0.554 km of Rhenok – Menla spur (NH-717B) Package-II A on EPC Basis under SARDP-NE Phase ‘A’ in the State of Sikkim.

S.No	Description	Side	Length (km)	Total Length
4.	Two lane including climbing lane with one side Paved shoulder New alignment (one Side Hill, one side Valley section)	1	0.380	0.380
5.	Two lane with Paved shoulder New alignment (one Side Hill, one side Valley section)	1	1.045	1.045
6.	Intermediate lane without paved shoulder concentric widening Both side hill	2	0.520	1.040
Total Length (km)				7.465

Catch Water Drains Location on Hill side (Cutting height is more than 10m)

Sr. No.	Left Side (m)	Right Side (m)
1	4340	4730

Therefore, total length of Lined & catch water drain will be **16.535 km.**

Footpath cum Drains Location:

TCS No.	Description	Length (m)	Side	Total Length (m)
Nil				

7. DESIGN OF STRUCTURES

7.1 General

7.1.1 All bridges, culverts and structures shall be designed and constructed in accordance with section 7 of the Manual and shall conform to the cross- sectional features and other details specified therein

7.1.2 Width of the carriageway of new bridges and structures shall be as follows:
[Refer to paragraph 7.1 (ii) of the Manual and specify the width of carriageway of new bridges and structures of more than 60 (sixty) meter length, if the carriageway width is different from 7.5 (seven point five) meter including kerb shyness in the table below.]

Sr. No.	Bridge (km)	Width of carriageway and Cross - Sectional feature
Nil		

7.1.3 The following structures shall be provided with footpaths:
[Refer to paragraph 7.1 (iii) of the Manual and provide details of new Structures with footpath.]

Sr. No.	Location at km		Remarks
	(Existing Chainage)	(Design Chainage)	
Nil			

Construction and upgradation of existing road to 2-lane with Paved shoulder from km. 20.340 (Rongli Bazzar) to km. 26.588 (Rongli Bypass End) and upgradation of existing road at km 20.600 & km 26.400 for length of 0.520 km & 0.554 km of Rhenok – Menla spur (NH-717B) Package-II A on EPC Basis under SARDP-NE Phase ‘A’ in the State of Sikkim.

7.1.4 All bridges shall be high-level bridges.

7.1.1 The following structures shall be designed to carry utility services specified in table below:

Sr. No.	Bridge (Km)	Utility service to be carried	Remarks
NIL			

7.1.2 Cross-section of the new culverts and bridges at deck level for the Project Highway shall conform to the typical cross-sections given in section 7 of the Manual.

7.2 Culverts

Overall width of all culverts shall be equal to the roadway width of the approaches.

7.2.1 Reconstruction of Existing Culverts:

The existing culverts at the following locations shall be reconstructed as new Box culverts:

Sl. No.	Ex. Chainage	Type	Size	Proposed Chainage	Proposed Size	Type	Proposal
1	0+000	Slab Culvert	1x0.75	20+440	1x2m	Box Culvert	Reconstruction
2	0+200	Causeway	-	20+640	1x3m	Box Culvert	Reconstruction
At Start Junction Ch. 20+600							
3	0+335	Slab Culvert	1x1.12	0+070	1x2m	Box Culvert	Reconstruction
4	0+587	Slab Culvert	1x1.10	0+352	1x2m	Box Culvert	Reconstruction
At End Junction Ch. 26+400							
5	3+875	Slab Culvert	1x0.60	0+010	1x2m	Box Culvert	Reconstruction
6	4+000	Slab Culvert	1x0.60	0+102	1x2m	Box Culvert	Reconstruction

7.2.2 Widening and Repairing of existing culverts

All existing culverts which are not to be reconstructed shall be widened to the roadway width of the Project Highway as per the typical cross section given in section 7 of the Manual. Repairs and strengthening of existing structures where required shall be carried out.

Sl. No.	Culvert Location (Km)	Type, Span, Height and width of existing culvert	Type of Repair Required
Nil			

7.2.3 Additional New culverts shall be constructed as per Particulars given in the table below:

Sl. No.	Proposed Chainage	Proposed Size	Type	Proposal
1	20+790	1x2m	Box Culvert	New Construction
2	21+150	1x2m	Box Culvert	New Construction
3	22+200	1x2m	Box Culvert	New Construction
4	22+830	1x2m	Box Culvert	New Construction

Construction and upgradation of existing road to 2-lane with Paved shoulder from km. 20.340 (Rongli Bazaar) to km. 26.588 (Rongli Bypass End) and upgradation of existing road at km 20.600 & km 26.400 for length of 0.520 km & 0.554 km of Rhenok – Menla spur (NH-717B) Package-II A on EPC Basis under SARDP-NE Phase ‘A’ in the State of Sikkim.

Sl. No.	Proposed Chainage	Proposed Size	Type	Proposal
5	23+270	1x2m	Box Culvert	New Construction
6	23+960	1x2m	Box Culvert	New Construction
7	25+460	1x2m	Box Culvert	New Construction

7.2.4 Repairs/ Replacement of Railing/Parapets, flooring and protection works of the existing culverts shall be undertaken as follows:

[Refer to paragraph 7.23 of the Manual and provide details]

Sr. No.	Existing Chainage (km)	Design Chainage (km)	Type of Culvert	Span (m)	Type of Repair
NIL					

7.2.5 Floor Protection works shall be as specified in the relevant IRC codes and specifications.

7.3 Bridges

7.3.1 Existing Bridges to be retained

(i) The existing minor bridges at the following locations shall be retained:

Sl. No.	Existing Chainage (Km)	Design Chainage (Km)	Design No. of Spans with span length (m)	Remarks
Nil				

(ii) The following Major bridges shall be reconstructed:

Sr. No.	Existing Chainage (Km)	Design Chainage (Km)	Design no. of Spans with span length (m)	Remarks
Nil				

(iii) The following Minor bridges shall be reconstructed:

Sl. No.	Existing Chainage (Km)	Design Chainage (Km)	Design no. of Spans with span length (m)	Existing no. of Spans with span length (m)	Existing Structure	Proposed Structure
Nil						

7.3.2 Additional New Bridges

a. New major bridge at the following locations on the project highway shall be constructed. GADs for the new bridges are attached in the drawings folder:

Sr. No.	Location		Span Arrangement	Total length (m)	Remarks
	Existing Chainage (Km)	Design Chainage (Km)			
NIL					

b. New minor bridges at the following locations on the project highway shall be constructed. GADs for the new bridges are attached in the drawings folder:

Sr. No.	Design Chainage	Span Arrangement	Total length (m)	Remarks
NIL				

7.3.3 The railings of existing bridges shall be Reconstruction by crash barriers at the following locations:

Sr. No.	Location (km)	Remarks
Nil		

7.3.4 Repairs/ replacements of railing/parapets of the existing bridges shall be undertaken as follows:

Sl. No.	Existing Chainage (Km)	Design Chainage (Km)	Existing no. of Spans with span length (m)	Remarks
Nil				

7.3.5 Drainage system for bridge decks

An effective drainage system for bridge decks shall be provided as specified in paragraph 7.21 of the Manual.

7.3.6 Structures in marine environment

[Refer to paragraph 7.22 of the Manual and specify the necessary measures / treatments for protecting structures in marine environment, where applicable]

7.4 Rail - Road Bridges

7.4.1 Design, construction and detailing of ROB/RUB shall be as specified in section 7 of the Manual. (Refer to paragraph 7.19 of the Manual and specify modification, if any)

7.4.2 Road Over-Bridges section

Road over-bridges (road over railway line) shall be provided at the following level crossings, as per manual:

Sl. No.	Location of Level crossing (Chainage km)	Length of bridge (m)	Type of structure	Remarks
NIL				

7.4.3 Road under-Bridges

Road under-bridges (road under railway line) shall be provided at the following level crossings, as per GAD drawings attached:

Sl. No.	Location of Level crossings (km)	Number and length of Span (m)
Nil		

7.5 Grade separated structures

(Refer to paragraph 7.20 of the Manual)

The grade separated structures shall be provided at the locations and of the type and length specified in paragraphs 2.9 and 3 of this Annex-I.

Sr. No.	Design Chainage	Span Arrangement	Total length (m)	Remarks
Nil				

7.6 Repairs and strengthening of bridges and structures

(Refer to paragraph 7.23 of the Manual and provide details)

All the existing bridges and structures to be repaired / strengthened, and the nature and extent of repairs/ strengthening required are given below:

A. Bridges

Sl. No.	Location / Design Chainage (In km)/Span	Side (LHS/RHS)	Nature and Extent of Repairs / Strengthening to be carried out
Nil			

B. ROB / RUB

Sl. No.	Location / Design Chainage (In km)	Side (LHS/RHS)	Nature and Extent of Repairs / Strengthening to be carried out
Nil			

C. Overpass / Underpass and Other structures

Sr. No.	Location / Design Chainage (In km)	Side (LHS/RHS)	Nature and Extent of Repairs/ Strengthening to be carried out
Nil			

7.7 List of Structures

Viaduct: The minimum requirement of Viaducts are suggested as following which may vary as per final drawings and design approved by competent authority. The Contractor is required to conduct detail investigation to assess the work based on site survey, investigations and assessment before commencement of work. Viaduct shall be provided where embankment height is more than 10m. Tentative locations of the Viaduct are given below :

Sl.	From (km)	To (km)	Length (km)	Length (m)	Span-Arrangement
1	20.880	20.980	0.10	100.00	5x20m
2	21.260	21.820	0.56	560.00	28x20m
3	23.470	23.750	0.28	280.00	14x20m
4	24.140	24.560	0.42	420.00	21x20m
5	24.660	24.840	0.18	180.00	9x20m
6	24.930	24.970	0.04	40.00	2x20m
7	25.630	25.870	0.24	240.00	12x20m
8	26.090	26.450	0.36	360.00	18x20m
Total Length (m)			2.18	2180	

***NOTE:-** The viaduct length mention above is exclusive of box abutment length. For total length of the elevated structure refer clause 2.11 and clause 13 of the same document.

8. TRAFFIC CONTROL DEVICES AND ROAD SAFETY WORKS

8.1 Traffic control devices and road safety works shall be provided in accordance with Section 9 of the Manual.

- (a) Traffic Signs: Traffic signs include roadside signs, overhead signs and curb mounted signs along the entire Project Highway.
- (b) Pavement Marking: Pavement markings shall cover road marking for the entire Project Highway.
- (c) Safety Barrier: Provide parapet along the project highway at all locations as specified in manual recommended in Schedule D.

8.2 Specifications of the reflecting sheeting.

Retro reflective sheeting should be of high intensity grade with encapsulated lens or with micro prismatic retro reflective element in accordance with ASTM Standard D 4956-04 and IRC 67:2010 shall be provided.

9. ROADSIDE FURNITURE

9.1 Roadside furniture shall be provided in accordance with the provisions of section 11 of the Manual.

- (a) Road Boundary Stone: For the entire Project Highway.
- (b) Pedestrian Guard Rail: The pedestrian facilities shall include the provision of the;
 - (i) Pedestrian guardrail: Provide pedestrian guardrail at each bus stop location.
 - (ii) Pedestrian Crossings: Provide pedestrian crossing facilities on Junctions.
- (c) Overhead traffic signs: Location and Size
 - (i) Full width Overhead signs: Full width Overhead signs shall be provided as suggested in manual recommended in Schedule D.
 - (ii) Cantilever Overhead signs: Overhead signs shall be provided as suggested in manual recommended in Schedule D.
 - (iii) Delineators: Delineators for the entire Project Highway at the locations as suggested in manual recommended in Schedule D. The minimum number of 2089 delineators to be provided in the curve portions for the entire project highway.

Note:- The no. of delineators mentioned above is minimum. Any increase in numbers shall not be constitute a Change of Scope

- (iv) Chevrons: Chevrons sign boards for the entire Project Highway at the locations as suggested in manual recommended in Schedule D. The minimum number of 2089 delineators to be provided in the curve portions for the entire project highway.

Note:- The no. of chevrons mentioned above is minimum. Any increase in numbers shall not be constitute a Change of Scope

10. COMPULSORY AFFORESTATION

The number of Trees which are required to be planted by the contractor as compensatory afforestation should be as per Forest Conservation Act, twice the number of trees to be cut.

11. HAZARDOUS LOCATIONS

The safety barriers (Parapet wall) shall also be provided at valley side for a length

of 9.104 Km. Parapet wall will construct at site as per requirement of location.

12. Special Requirement for Hill Roads

12.1 Retaining Wall: - The minimum requirement of Retaining wall are suggested as following which may vary as per final drawings and design approved by competent authority. The Contractor is required to conduct detail investigation to assess the work based on site survey, investigations and assessment before commencement of work.

Retaining Walls Locations LHS:

Filling Left					Filling Left				
Sl.No.	Chainge From	Chainge To	Length (m)	LVL	Sl.No.	Chainge From	Chainge To	Length (m)	LVL
1	20+340	20+360	20	4	134	23+000	23+010	10	8
2	20+670	20+680	10	4	135	23+010	23+020	10	9
9	20+680	20+690	10	5	136	23+020	23+030	10	10
10	20+690	20+700	10	6	137	23+030	23+040	10	11
11	20+700	20+710	10	7	138	23+040	23+050	10	11
12	20+710	20+720	10	8	139	23+050	23+060	10	11
13	20+720	20+730	10	8	140	23+060	23+070	10	8
18	20+730	20+740	10	9	141	23+070	23+080	10	7
19	20+740	20+750	10	8	142	23+110	23+120	10	6
20	20+750	20+760	10	11	143	23+120	23+130	10	9
21	20+770	20+780	10	11	144	23+130	23+140	10	9
22	20+780	20+790	10	9	145	23+140	23+150	10	7
23	20+790	20+800	10	6	146	23+150	23+160	10	5
24	20+800	20+810	10	6	147	23+160	23+170	10	7
25	20+810	20+820	10	7	148	23+170	23+180	10	9
30	20+820	20+830	10	8	149	23+180	23+190	10	10
31	20+830	20+840	10	7	150	23+190	23+200	10	9
32	20+840	20+850	10	6	151	23+200	23+210	10	10
33	20+850	20+860	10	7	152	23+210	23+220	10	10
38	20+860	20+870	10	9	153	23+220	23+230	10	10
47	20+980	20+990	10	9	154	23+230	23+240	10	11
48	20+990	21+000	10	7	155	23+240	23+250	10	11
49	21+000	21+010	10	6	156	23+250	23+260	10	10
50	21+010	21+020	10	6	157	23+260	23+270	10	10
51	21+020	21+030	10	4	158	23+270	23+280	10	10
52	21+070	21+080	10	5	159	23+280	23+290	10	9
53	21+080	21+090	10	6	160	23+290	23+300	10	9
54	21+090	21+100	10	7	161	23+300	23+310	10	9
55	21+100	21+110	10	8	162	23+310	23+320	10	8
56	21+110	21+120	10	10	163	23+320	23+330	10	8
57	21+120	21+130	10	10	164	23+330	23+340	10	7
58	21+130	21+140	10	10	165	23+340	23+350	10	6
59	21+140	21+150	10	9	166	23+350	23+360	10	6
60	21+150	21+160	10	8	167	23+450	23+460	10	6

Construction and upgradation of existing road to 2-lane with Paved shoulder from km. 20.340 (Rongli Bazzar) to km. 26.588 (Rongli Bypass End) and upgradation of existing road at km 20.600 & km 26.400 for length of 0.520 km & 0.554 km of Rhenok – Menla spur (NH-717B) Package-II A on EPC Basis under SARDP-NE Phase ‘A’ in the State of Sikkim.

Filling Left					Filling Left				
Sl.No.	Chainge From	Chainge To	Length (m)	LVL	Sl.No.	Chainge From	Chainge To	Length (m)	LVL
61	21+160	21+170	10	6	168	23+930	23+940	10	5
62	21+170	21+180	10	6	169	23+960	23+970	10	8
63	21+180	21+190	10	6	170	24+560	24+570	10	7
64	21+190	21+200	10	5	171	24+620	24+630	10	5
65	21+200	21+210	10	4	172	24+630	24+640	10	6
66	21+230	21+240	10	6	173	24+640	24+650	10	8
75	21+240	21+250	10	8	174	24+970	24+980	10	6
112	22+820	22+830	10	7	175	25+430	25+440	10	7
113	22+830	22+840	10	8	176	25+440	25+450	10	7
114	22+840	22+850	10	9	177	25+450	25+460	10	5
115	22+850	22+860	10	9	178	25+590	25+600	10	4
116	22+860	22+870	10	5	179	25+600	25+610	10	6
121	22+930	22+940	10	5	180	25+610	25+620	10	8
128	22+940	22+950	10	6	181	25+870	25+880	10	8
129	22+950	22+960	10	6	182	25+880	25+890	10	5
130	22+960	22+970	10	6	183	26+450	26+460	10	7
131	22+970	22+980	10	9	184	26+480	26+490	10	4
132	22+980	22+990	10	9	185	26+550	26+560	10	4
133	22+990	23+000	10	10	186	26+560	26+570	10	5
					187	26+570	26+580	10	5
					188	26+580	26+590	10	5
					189	26+585	26+588	3	5

Retaining Walls Locations RHS:

Filling Right					Filling Right				
Sl.No.	Chainage From	Chinage To	Length (m)	Height (m)	Sl.No.	Chainage From	Chinage To	Length (m)	Height (m)
1	20+740	20+750	10	4	18	23+230	23+240	10	6
2	20+750	20+760	10	8	19	23+240	23+250	10	7
3	20+760	20+770	10	7	20	23+250	23+260	10	7
4	20+770	20+780	10	6	21	23+260	23+270	10	6
5	21+170	21+180	10	5	22	23+270	23+280	10	5
6	22+970	22+980	10	5	23	23+930	23+940	10	9
7	22+980	22+990	10	6	24	23+940	23+950	10	11
8	22+990	23+000	10	6	25	23+950	23+960	10	8
9	23+000	23+010	10	6	26	23+960	23+970	10	8
10	23+010	23+020	10	6	27	23+970	23+980	10	11
11	23+020	23+030	10	8	28	24+110	24+120	10	5
12	23+030	23+040	10	8	29	24+120	24+130	10	9
13	23+040	23+050	10	7	30	24+560	24+570	10	5
14	23+050	23+060	10	4	31	25+610	25+620	10	6
15	23+200	23+210	10	4	32	25+870	25+880	10	8
16	23+210	23+220	10	6	33	25+880	25+890	10	5

Construction and upgradation of existing road to 2-lane with Paved shoulder from km. 20.340 (Rongli Bazzar) to km. 26.588 (Rongli Bypass End) and upgradation of existing road at km 20.600 & km 26.400 for length of 0.520 km & 0.554 km of Rhenok – Menla spur (NH-717B) Package-II A on EPC Basis under SARDP-NE Phase ‘A’ in the State of Sikkim.

Filling Right					Filling Right				
Sl.No.	Chainage From	Chainage To	Length (m)	Height (m)	Sl.No.	Chainage From	Chainage To	Length (m)	Height (m)
17	23+220	23+230	10	6	34	26+070	26+080	10	6

12.2 Breast Wall :

The minimum requirement of 4m height Breast wall are suggested as following which may vary as per final drawings and design approved by competent authority. The Contractor is required to conduct detail investigation to assess the work based on site survey, investigations and assessment before commencement of work. Hill cutting slope should not exceed 60 degrees, 1.5m benching to be provided at least every 10m height.

Breast Wall	Left Side Length (m)	Right Side Length (m)
	4340	4730

12.3 Hydroseeding

To control soil erosion and re-vegetate areas in hill side, hydroseeding to be provided in total area of 7845.1 m² by mechanical means where height is between 20-30m.

Note: Any variations in the area specified mentioned above shall not constitute a Change of Scope

12.4 Slope Protection in Hill Cut Sections (4-20m)

At location where hill cutting is between 4m to 20m, required Breast wall to be provided upto 4m height and between 4m to 20m, slope to be protected with Earth anchors, Helical Pins and Turf reinforced mat. The technical specification and item description for Earth anchors, Helical Pins and Turf reinforced mat are given below.

- Providing Flexible Earth Percussion Anchor with three part system consisting of Anchor head with material composition of Zinc-Aluminium Alloy ZA-3, Load bearing plate material composition of Die Cast Zinc-Aluminium Alloy ZA-2 ; Utilizing a Ceramic Roller & Directional Locking Device connected by wire rope tendon which is Zinc Aluminium Coated and a ferrule, Diameter of wire rope tendon ranges from 3mm, 4mm or 6mm . The Anchor assembly Ultimate Strength varies between a minimum of 500kg to a maximum of 1270Kg. The anchor drive depth varies between 0.5m to 2m. Anchor performance is a function of in situ soil strength and therefore the load range in this specification should be regarded as a guide only.
- Providing Helical pins to hold the turf reinforcement mat in position and shall be driven for permanent tie down of the surface protection material in locations specified in the drawings. The pin system shall be made of materials suitable to resist corrosion typically Zinc + Aluminium coated and shall conform to BS10270-1. The top coil of the pin system shall be formed for interaction with installation tools. The pin shall have a minimum drive depth of 0.2m and maximum drive depth of 0.3m
- Providing machine made mat of 100% Coconut fibre matrix incorporated into permanent three-dimensional turf reinforcement matting. The matrix is evenly distributed across entire width of mat and stitch bonded between ultra-heavy duty UV stabilised netting with thickness of mat as 18.54mm with heavy duty Helical pins to keep the erosion control mats in position and in close contact with underlying slope with a minimum drive depth of 200mm and maximum drive depth of 300mm, specifically designed for tougher soils and superior performance.

The minimum quantity of protection works may be taken as below

Note: Any variations in the area specified mentioned above shall not constitute a Change of Scope

13. CHANGE OF SCOPE

The length of Viaducts, Culverts, Retaining Walls, Breast Walls, Bridges etc. specified here in above shall be treated as an approximate assessment. The actual lengths as required on the basis of detailed investigations shall be determined by the Contractor in accordance with the Specifications and Standards. Any variations in the lengths specified in this Schedule-B shall not constitute a Change of Scope, save and except any variations in the length arising out of a Change of Scope expressly undertaken in accordance with the provisions of Article 13.

SCHEDULE - C
(See Clause 2.1)

PROJECT FACILITIES

1 Project Facilities

The Contractor shall construct the Project Facilities in accordance with the provisions of this Agreement. Such Project Facilities shall include:

- (a) Toll plaza;
- (b) Roadside furniture;
- (c) Pedestrian facilities;
- (d) Tree plantation;
- (e) Truck lay-byes;
- (f) Bus stop and shelters;
- (h) Rest areas; and
- (i) Others to be specified

2 Description of Project Facilities

Each of the Project Facilities is described below showing:

(a) Toll Plaza

Toll plaza shall be designed as per the guidelines of manual and it is provided at following locations:

Sl. No.	Toll Plaza Location (Design Chainage in Km)
	Nil

(b) Roadside Furniture

The roadside furniture shall include the provision of the;

i. Traffic Signs

Typical drawings of Traffic signs include roadside signs, overhead signs and curb mounted signs etc provided for the entire Project Highway is given and location of the same shall be as per IRC 67 recommended in Schedule D.

ii. Pavement Markings

Pavement markings shall cover road marking for the entire Project Highway as per manual recommended in Schedule D.

iii. LED Traffic Blinkers

LED traffic blinker signal provided for entire project.

iv. Crash barrier

Provide W-beam crash barrier along the project highway at the locations as suggested in manual recommended in Schedule D.

v. Delineators

Delineators for the entire Project Highway at the locations as suggested in relevant IRC Manual recommended in Schedule D.

vi. Boundary stones

For the entire Project Highway as suggested in relevant IRC Manual recommended in Schedule D.

vii. Hectometer / Kilometer stones

For the entire Project Highway as suggested in relevant IRC Manual recommended in Schedule D.

(c) Pedestrian Facilities

The pedestrian facilities shall include the provision of the;

- i. Pedestrian guardrail: Provide pedestrian guardrail at each bus stop location.
- ii. Pedestrian Crossings: Provide pedestrian crossing facilities on locations as recommended in Schedule D.

(d) Landscaping and Tree Plantation

The landscaping and tree plantation shall be provided. The locations for these provisions shall be finalized in consultation with Independent Engineer.

(e) Truck Lay-byes

Truck lay byes shall be provided at the following locations for a capacity of minimum 10 trucks at each location.

Sr. No.	Proposed Ch.
	Nil

(f) Bus Shelter

Bus Shelters shall be provided at locations given below:

Sr. No.	Proposed Chainage	Direction
1.	20+400	LHS
2.	21+200	LHS
3.	25+500	LHS
4.	26+500	LHS

(g) Rest Areas,

Nil.

(h) Others

1. Highway Lighting

Lighting shall be provided at the following locations (Minimum 40 Lux to be maintained):

- (i) Lighting shall be provided at approach to bridges, Built up areas, Toll plaza, Bus shelter, truck Lay-bys, and as per manual recommended in Schedule D.
- (ii) High Mast Lighting shall be provided at all Major Junctions, Toll plaza locations,

2. Highway Patrol

Not applicable

3. Ambulances

Not applicable

4. Cranes

Not applicable

5. Advance Traffic Management System (ATMS)

Not applicable

SCHEDULE - D
(See Clause 2.1)

SPECIFICATIONS AND STANDARDS

1 Construction

The Contractor shall comply with the Specifications and Standards set forth in Annex-I of this Schedule-D for construction of the Project Highway.

2 Design Standards

The Project Highway including Project Facilities shall conform to design requirements set out in the following documents:

Manual of Specifications and Standards for Two Lanning of Highways (IRC: SP: 73-2018), referred to herein as the Manual.

IRC-37-2018: Guidelines for the design of flexible pavements

Code for Practice of Road Signs IRC 67:2001.

The Hill Road Manual IRC SP 48 -1998 should be referred.

The NGT Order dated 01.11.2018 should be followed for disposal of muck.

Annex – I
(Schedule-D)

Specifications and Standards for Construction

1 Specifications and Standards

All Materials, works and construction operations shall conform to the Manual of Specifications and Standards for Two-Laning of Highways (IRC:SP:73-2018), referred to as the Manual, and MORTH Specifications for Road and Bridge Works. Where the specification for a work is not given, Good Industry Practice shall be adopted to the satisfaction of the Authority’s Engineer.

2 Deviations from the Specifications and Standards

- 1.1** The terms “Concessionaire”, “Independent Engineer” and “Concession Agreement” used in the Manual shall be deemed to be substituted by the terms “Contractor”, “Authority’s Engineer” and “Agreement” respectively.
- 1.2** Notwithstanding anything to the contrary contained in Paragraph 1 above, the following Specifications and Standards shall apply to the Project Highway, and for purposes of this Agreement, the aforesaid Specifications and Standards shall be deemed to be amended to the extent as set forth below:-

Clause Referred in Manual	Item	Provision as per Manual	Modified Provision	Remarks
2.16	Typical Cross Section	10.0 m Paved and 1.0m Earthen Shoulder	As specified in Schedule B	-
2.2.1	Minimum design speed in hilly terrain.	40 kmph	At some locations , where the horizontal curve radius is not meeting the criteria as per clause 2.9.4 and table 2.5 of IRC:SP:73-2018.	Speed is restricted for Curve having radius less 50m.

Construction and upgradation of existing road to 2-lane with Paved shoulder from km. 20.340 (Rongli Bazzar) to km. 26.588 (Rongli Bypass End) and upgradation of existing road at km 20.600 & km 26.400 for length of 0.520 km & 0.554 km of Rhenok – Menla spur (NH-717B) Package-II A on EPC Basis under SARDP-NE Phase ‘A’ in the State of Sikkim.

Applicable Typical Cross Section:

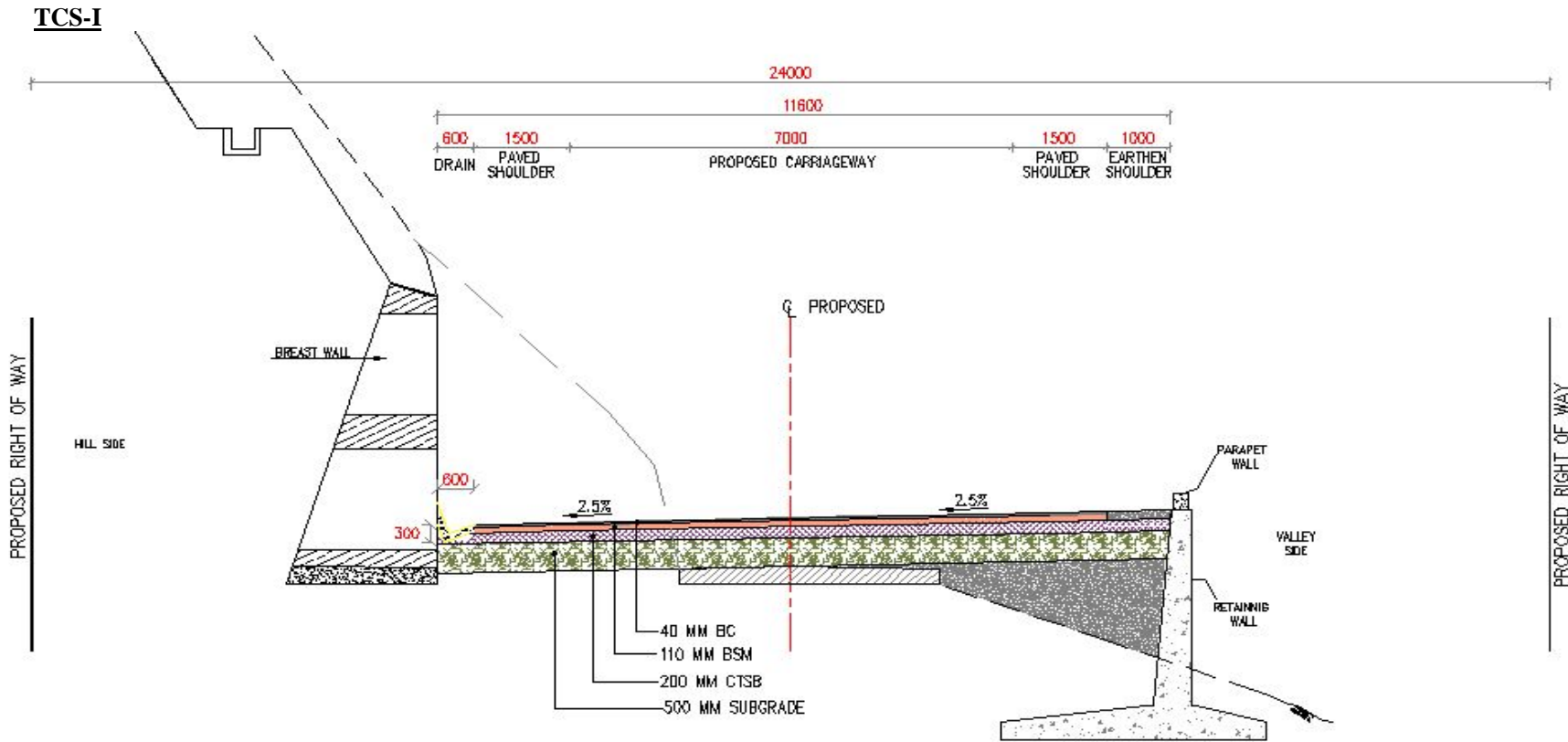

TCS-I
Two Lane With Paved Shoulder Concentric Widening (One Side Hill One Side Valley Section)

Construction and upgradation of existing road to 2-lane with Paved shoulder from km. 20.340 (Rongli Bazaar) to km. 26.588 (Rongli Bypass End) and upgradation of existing road at km 20.600 & km 26.400 for length of 0.520 km & 0.554 km of Rhenok – Menla spur (NH-717B) Package-II A on EPC Basis under SARDP-NE Phase 'A' in the State of Sikkim.

TCS-II

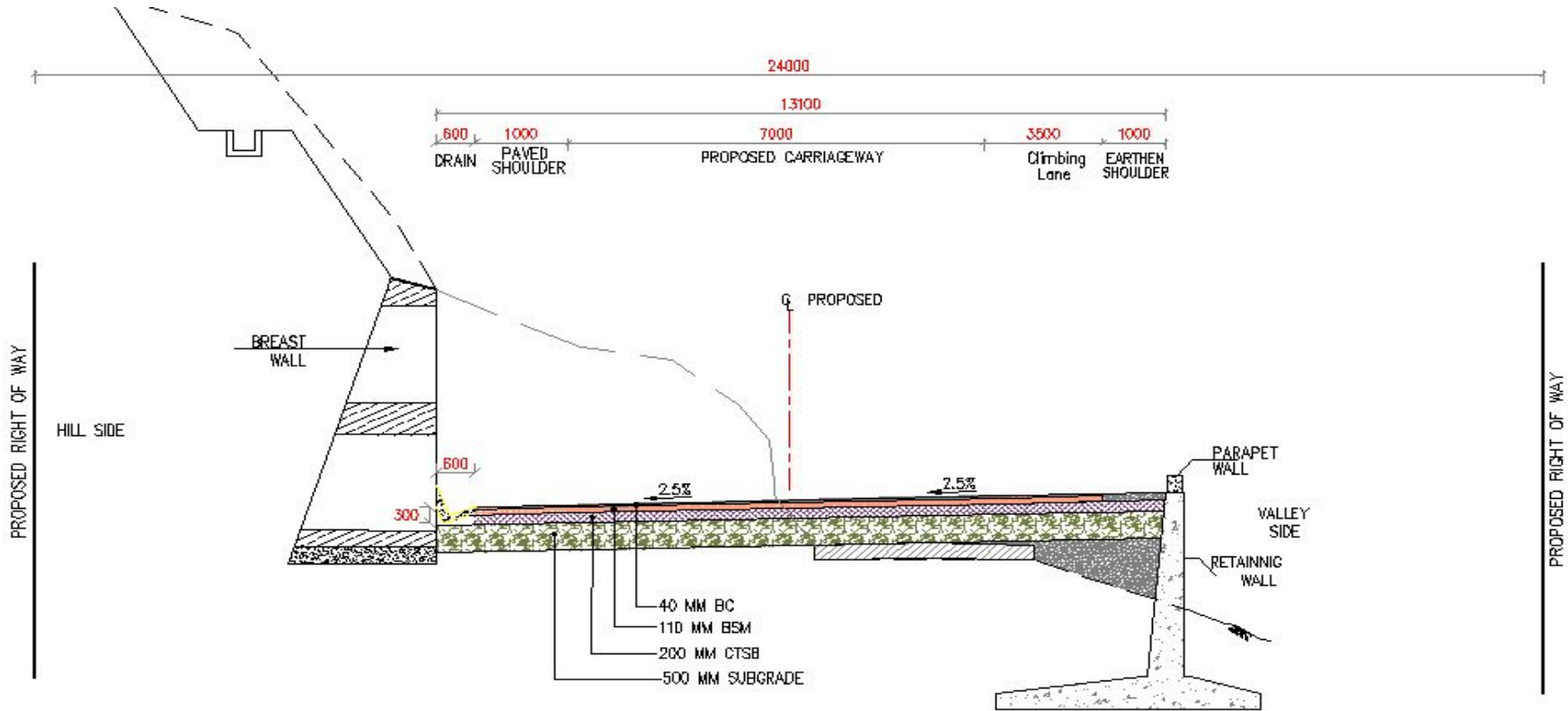

TCS-II

Two Lane including Climbing Lane With one side Paved Shoulder Eccentric Left Side Widening (One Side Hill One Side Valley Section)

Construction and upgradation of existing road to 2-lane with Paved shoulder from km. 20.340 (Rongli Bazaar) to km. 26.588 (Rongli Bypass End) and upgradation of existing road at km 20.600 & km 26.400 for length of 0.520 km & 0.554 km of Rhenok – Menla spur (NH-717B) Package-II A on EPC Basis under SARDP-NE Phase 'A' in the State of Sikkim.

TCS-III

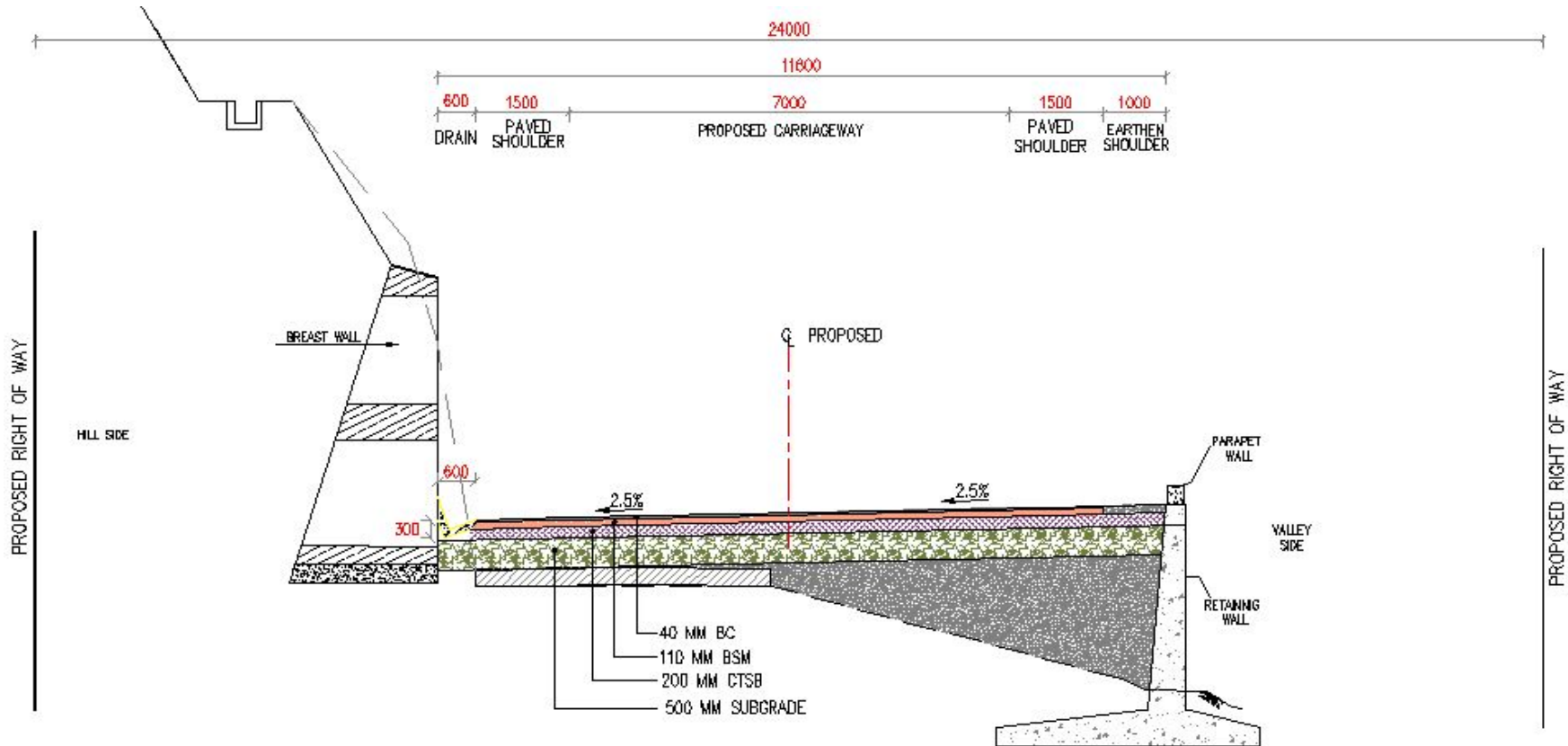

TCS-III

Two Lane With Paved Should Eccentric Right Widening (One Side Hill One Side Valley Section)

Construction and upgradation of existing road to 2-lane with Paved shoulder from km. 20.340 (Rongli Bazaar) to km. 26.588 (Rongli Bypass End) and upgradation of existing road at km 20.600 & km 26.400 for length of 0.520 km & 0.554 km of Rhenok – Menla spur (NH-717B) Package-II A on EPC Basis under SARDP-NE Phase 'A' in the State of Sikkim.

TCS-IV

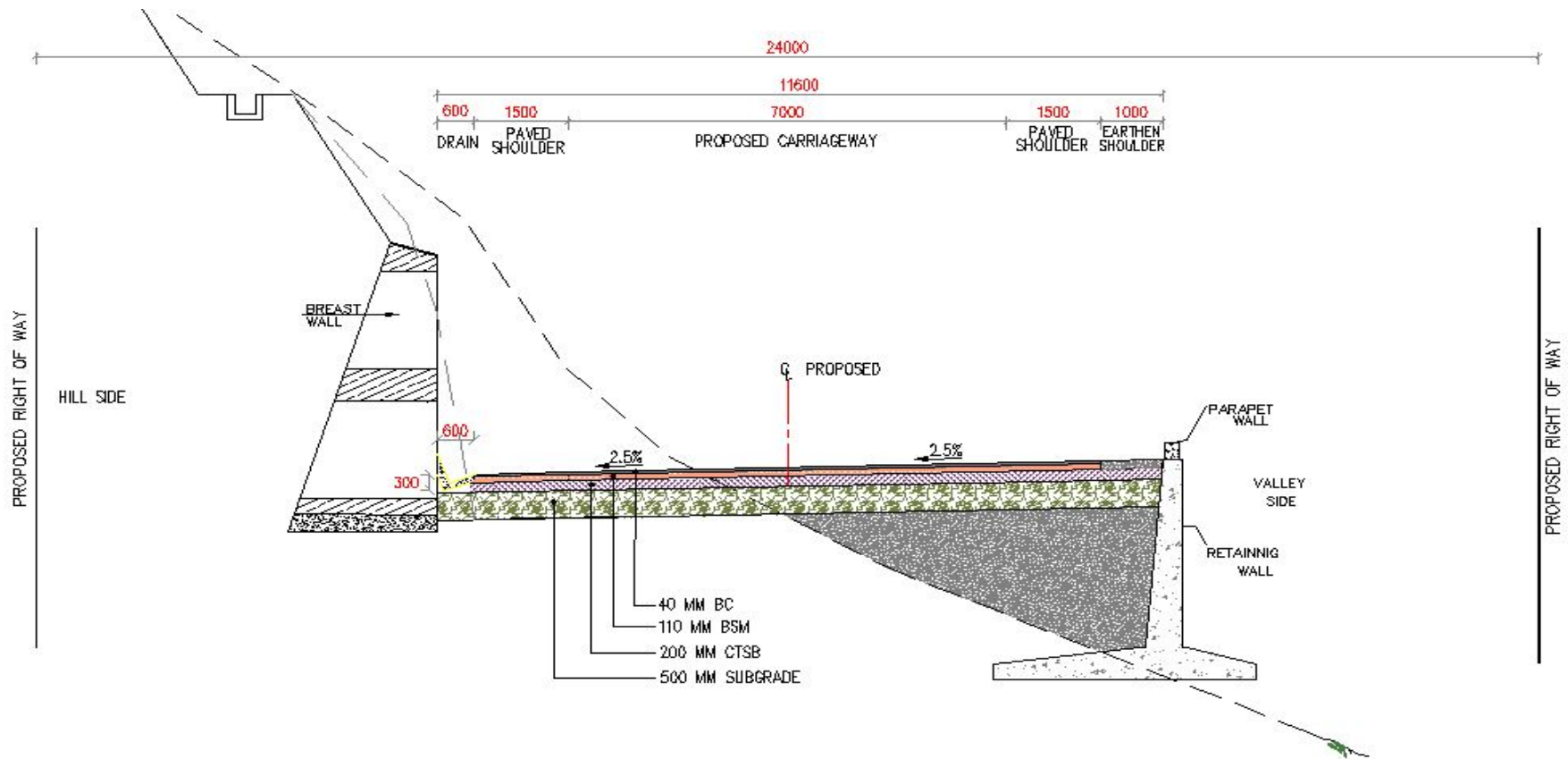

TCS-IV
Two Lane With Paved Shoulder (One Side Hill One Side Valley Section)
(Re-Alignment)

Construction and upgradation of existing road to 2-lane with Paved shoulder from km. 20.340 (Rongli Bazaar) to km. 26.588 (Rongli Bypass End) and upgradation of existing road at km 20.600 & km 26.400 for length of 0.520 km & 0.554 km of Rhenok – Menla spur (NH-717B) Package-II A on EPC Basis under SARDP-NE Phase ‘A’ in the State of Sikkim.

TCS-IV A

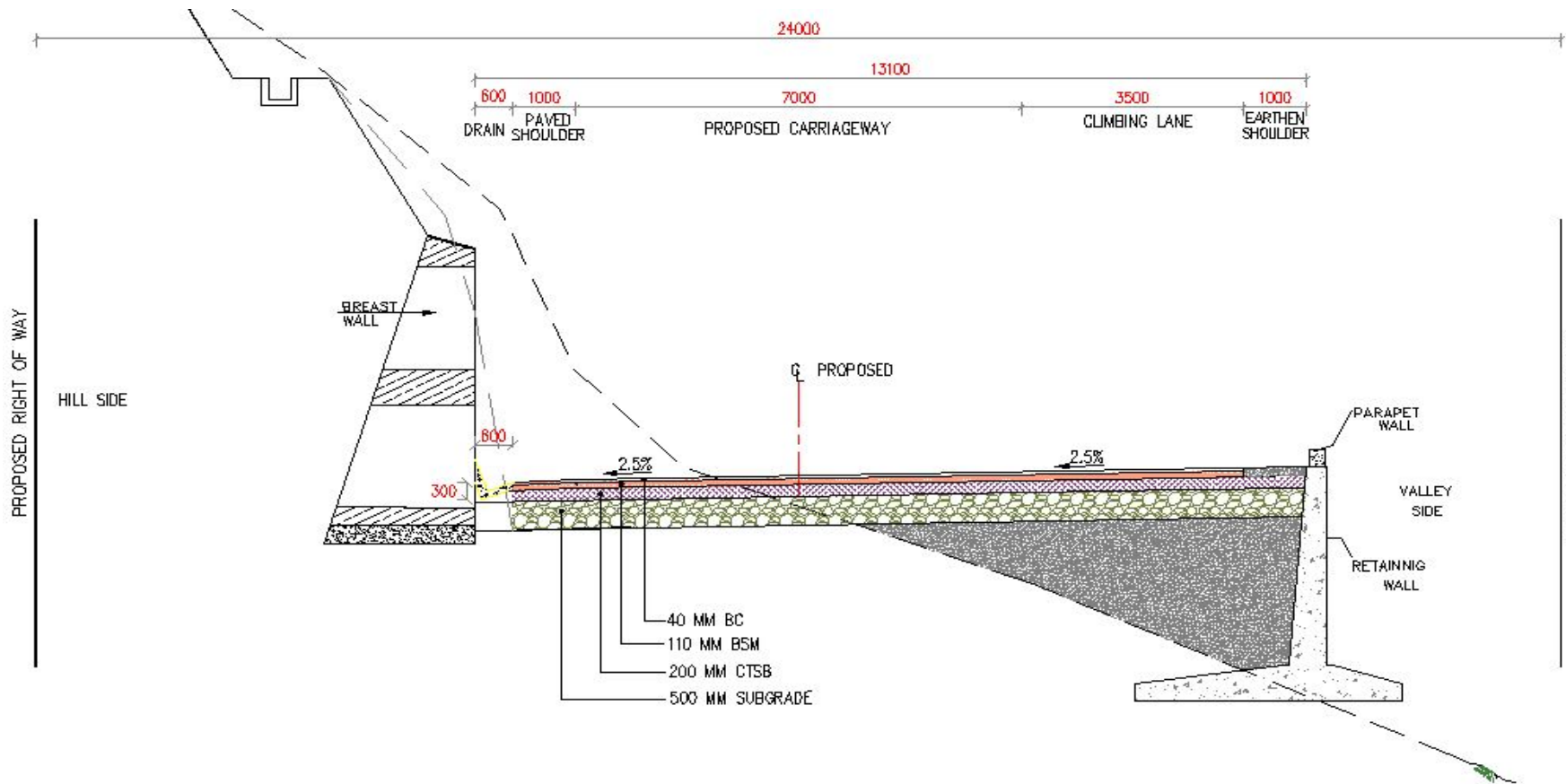

TCS-IVA
Two lane including climbing lane with one side Paved shoulder Realignment
(One Side Hill, One side Valley section)

Construction and upgradation of existing road to 2-lane with Paved shoulder from km. 20.340 (Rongli Bazzar) to km. 26.588 (Rongli Bypass End) and upgradation of existing road at km 20.600 & km 26.400 for length of 0.520 km & 0.554 km of Rhenok – Menla spur (NH-717B) Package-II A on EPC Basis under SARDP-NE Phase 'A' in the State of Sikkim.

TCS-V

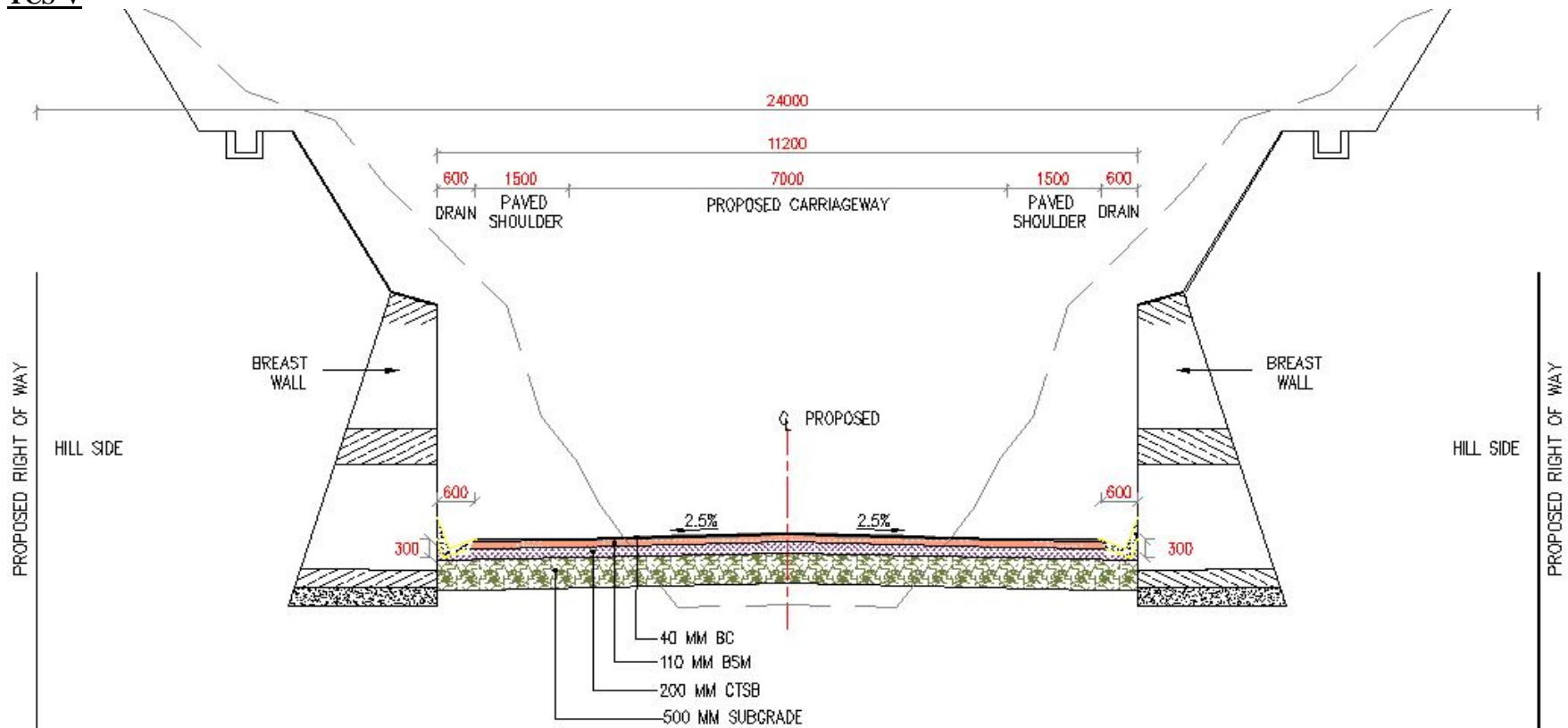

TCS-V
Two Lane With Paved Shoulder Concentric Widening (Both Side Hill Section)

Construction and upgradation of existing road to 2-lane with Paved shoulder from km. 20.340 (Rongli Bazzar) to km. 26.588 (Rongli Bypass End) and upgradation of existing road at km 20.600 & km 26.400 for length of 0.520 km & 0.554 km of Rhenok – Menla spur (NH-717B) Package-II A on EPC Basis under SARDP-NE Phase 'A' in the State of Sikkim.

TCS V A

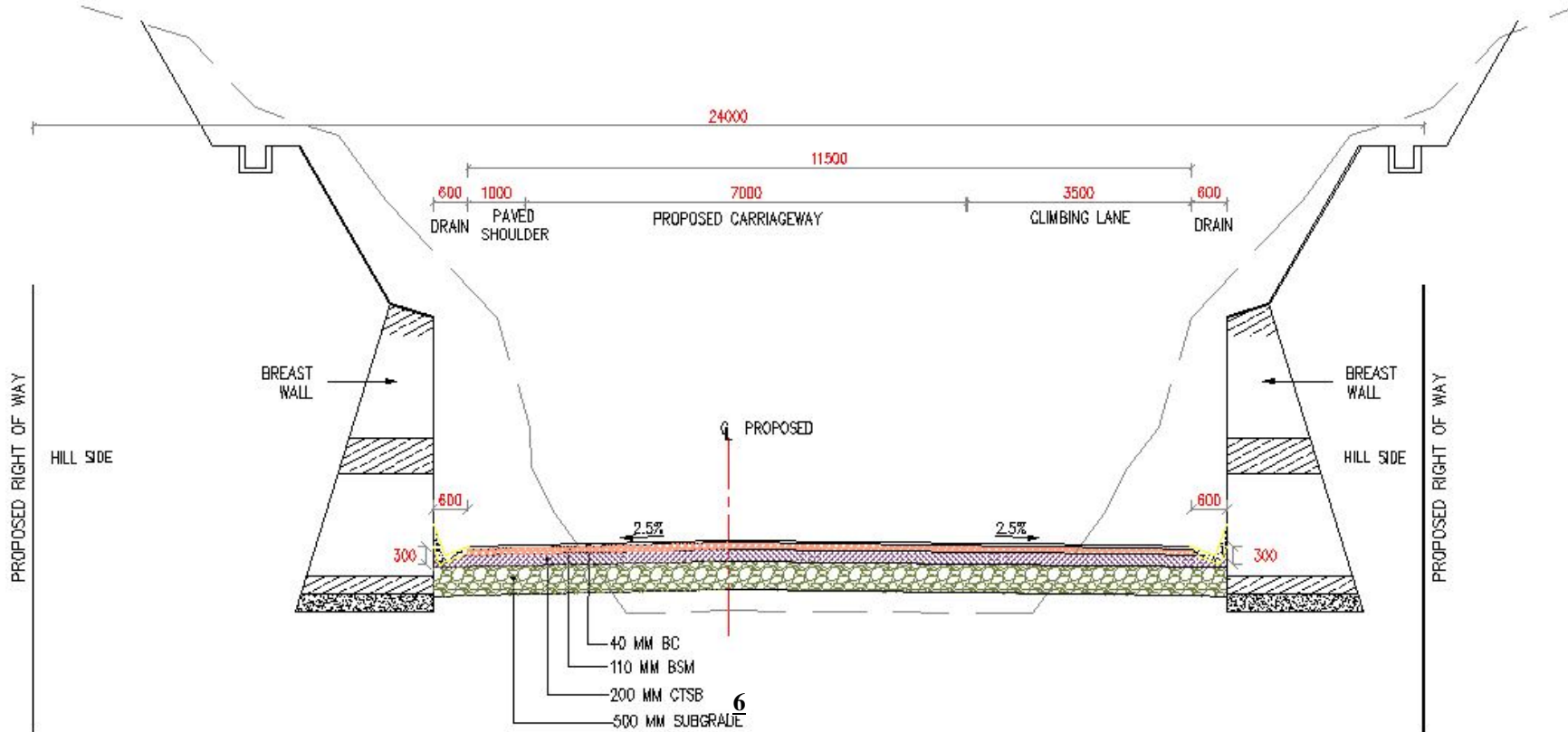

TCS-VA
Two lane including climbing lane with one side Paved shoulder Concentric Widening
(Both Side Hill)

Construction and upgradation of existing road to 2-lane with Paved shoulder from km. 20.340 (Rongli Bazaar) to km. 26.588 (Rongli Bypass End) and upgradation of existing road at km 20.600 & km 26.400 for length of 0.520 km & 0.554 km of Rhenok – Menla spur (NH-717B) Package-II A on EPC Basis under SARDP-NE Phase 'A' in the State of Sikkim.

TCS VI

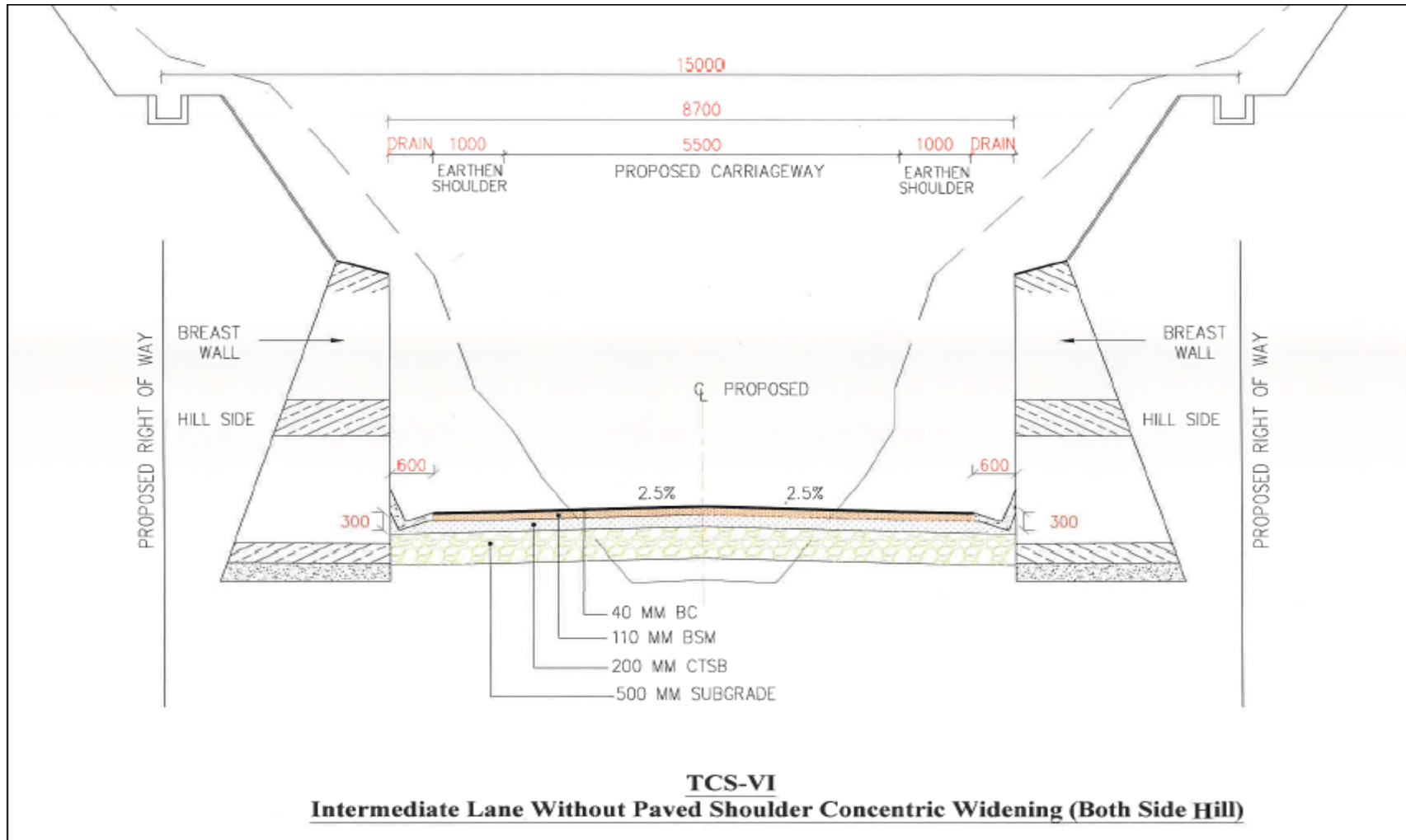

Construction and upgradation of existing road to 2-lane with Paved shoulder from km. 20.340 (Rongli Bazzar) to km. 26.588 (Rongli Bypass End) and upgradation of existing road at km 20.600 & km 26.400 for length of 0.520 km & 0.554 km of Rhenok – Menla spur (NH-717B) Package-II A on EPC Basis under SARDP-NE Phase 'A' in the State of Sikkim.

TCS VIA

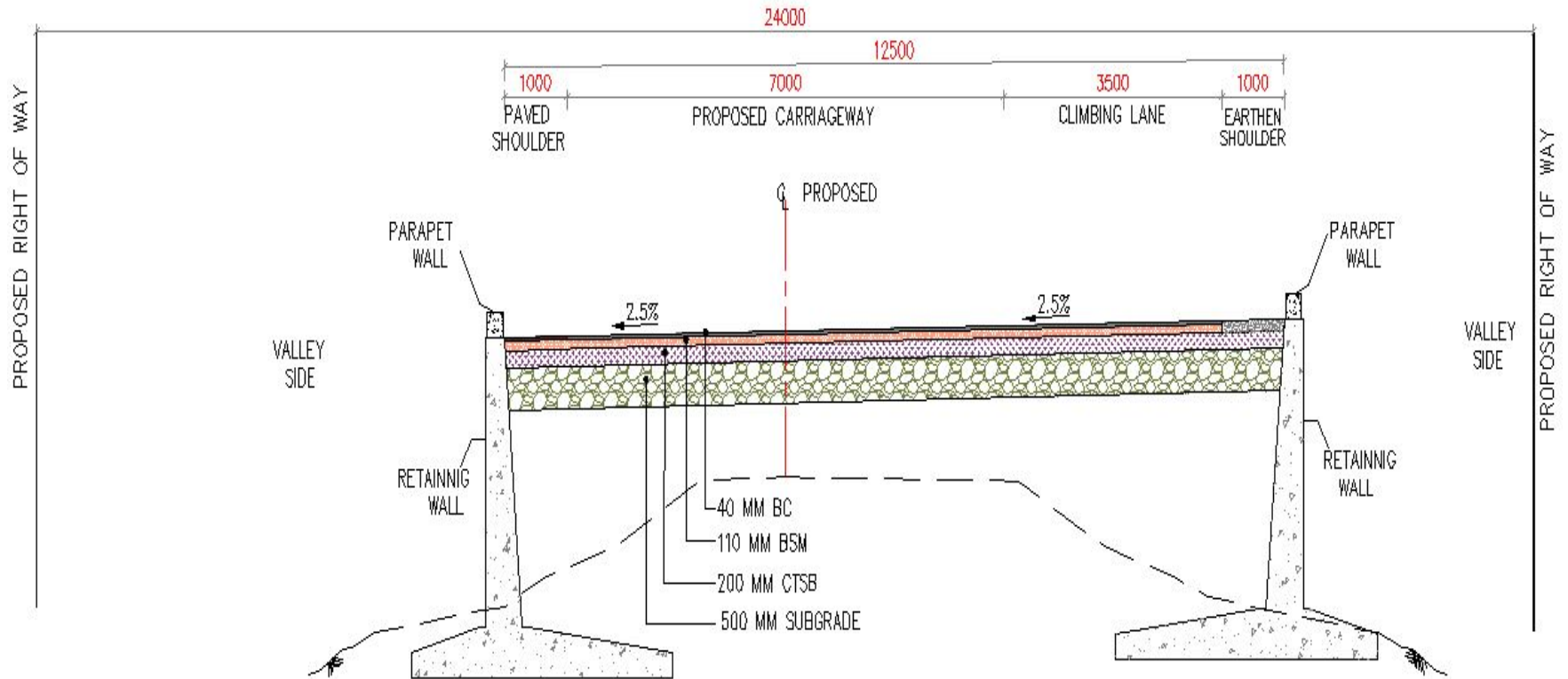

TCS-VIA

**Two lane including climbing lane with one side Paved shoulder Concentric
(Both Side Valley section)**

Construction and upgradation of existing road to 2-lane with Paved shoulder from km. 20.340 (Rongli Bazzar) to km. 26.588 (Rongli Bypass End) and upgradation of existing road at km 20.600 & km 26.400 for length of 0.520 km & 0.554 km of Rhenok – Menla spur (NH-717B) Package-II A on EPC Basis under SARDP-NE Phase 'A' in the State of Sikkim.

TCS VII

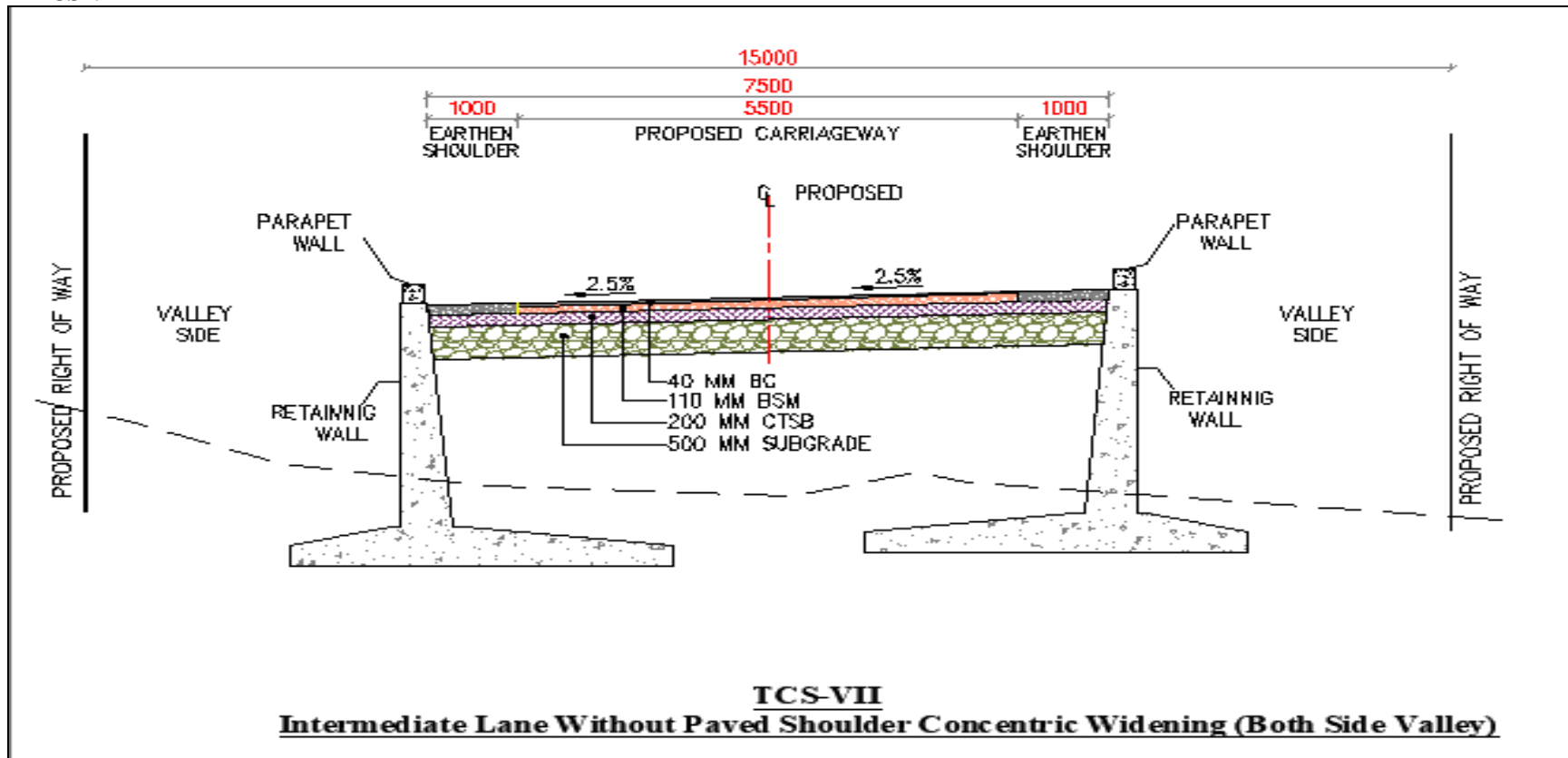

Construction and upgradation of existing road to 2-lane with Paved shoulder from km. 20.340 (Rongli Bazaar) to km. 26.588 (Rongli Bypass End) and upgradation of existing road at km 20.600 & km 26.400 for length of 0.520 km & 0.554 km of Rhenok – Menla spur (NH-717B) Package-II A on EPC Basis under SARDP-NE Phase 'A' in the State of Sikkim.

TCS VII A

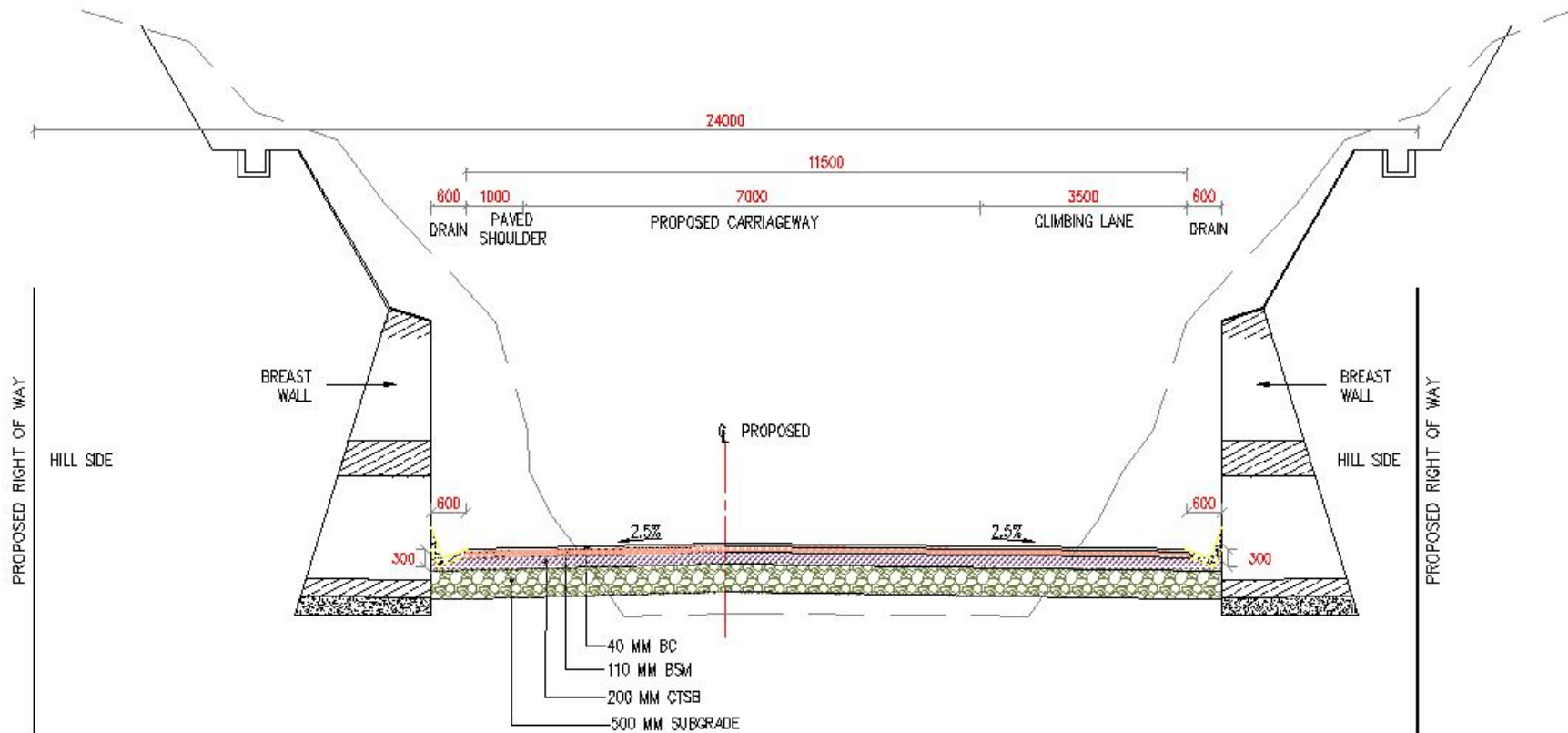

TCS-VIIA
Two lane including climbing lane with one side Paved shoulder Realignment
(Both Side Hill)

Construction and upgradation of existing road to 2-lane with Paved shoulder from km. 20.340 (Rongli Bazaar) to km. 26.588 (Rongli Bypass End) and upgradation of existing road at km 20.600 & km 26.400 for length of 0.520 km & 0.554 km of Rhenok – Menla spur (NH-717B) Package-II A on EPC Basis under SARDP-NE Phase 'A' in the State of Sikkim.

TCS VIII

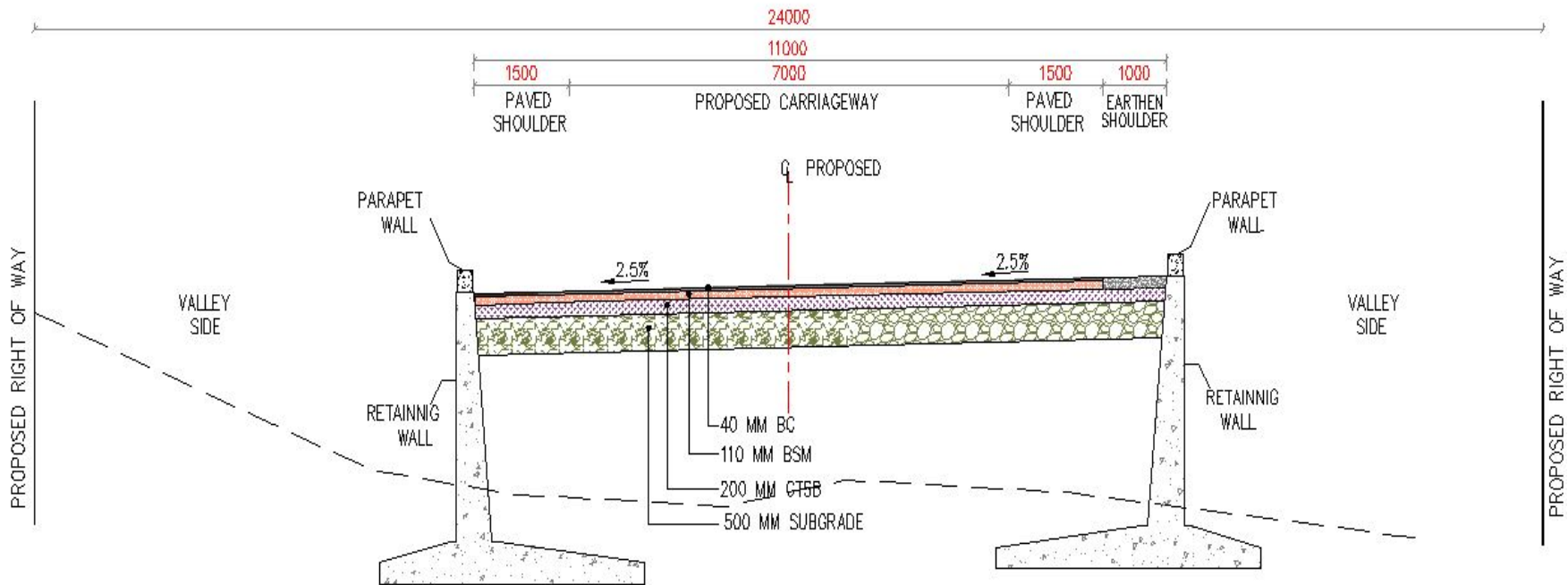

TCS-VIII
Two Lane With Paved Shoulder (Both Side Valley Section)
(Re-Alignment)

Construction and upgradation of existing road to 2-lane with Paved shoulder from km. 20.340 (Rongli Bazzar) to km. 26.588 (Rongli Bypass End) and upgradation of existing road at km 20.600 & km 26.400 for length of 0.520 km & 0.554 km of Rhenok – Menla spur (NH-717B) Package-II A on EPC Basis under SARDP-NE Phase 'A' in the State of Sikkim.

TCS VIII A

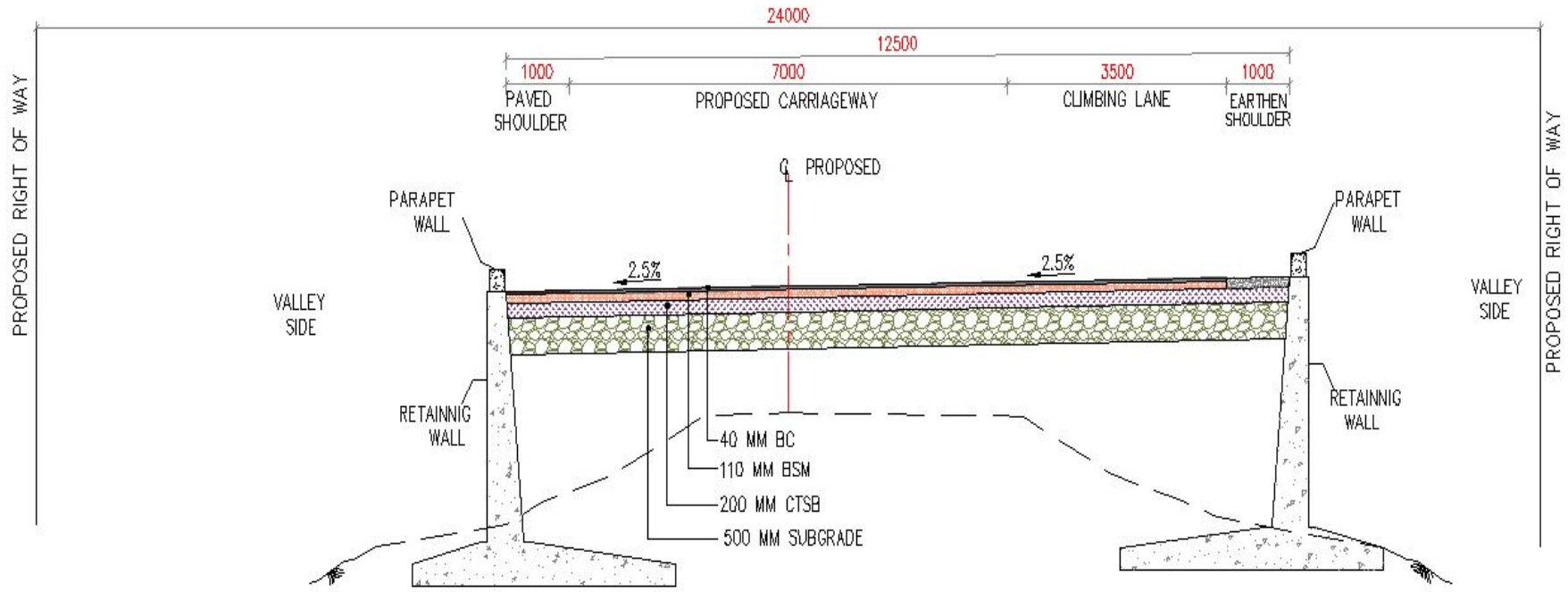

TCS-VIIIA
Two lane including climbing lane with one side Paved shoulder Realignment
(Both Side Valley section)

Construction and upgradation of existing road to 2-lane with Paved shoulder from km. 20.340 (Rongli Bazzar) to km. 26.588 (Rongli Bypass End) and upgradation of existing road at km 20.600 & km 26.400 for length of 0.520 km & 0.554 km of Rhenok – Menla spur (NH-717B) Package-II A on EPC Basis under SARDP-NE Phase 'A' in the State of Sikkim.

TCS IX

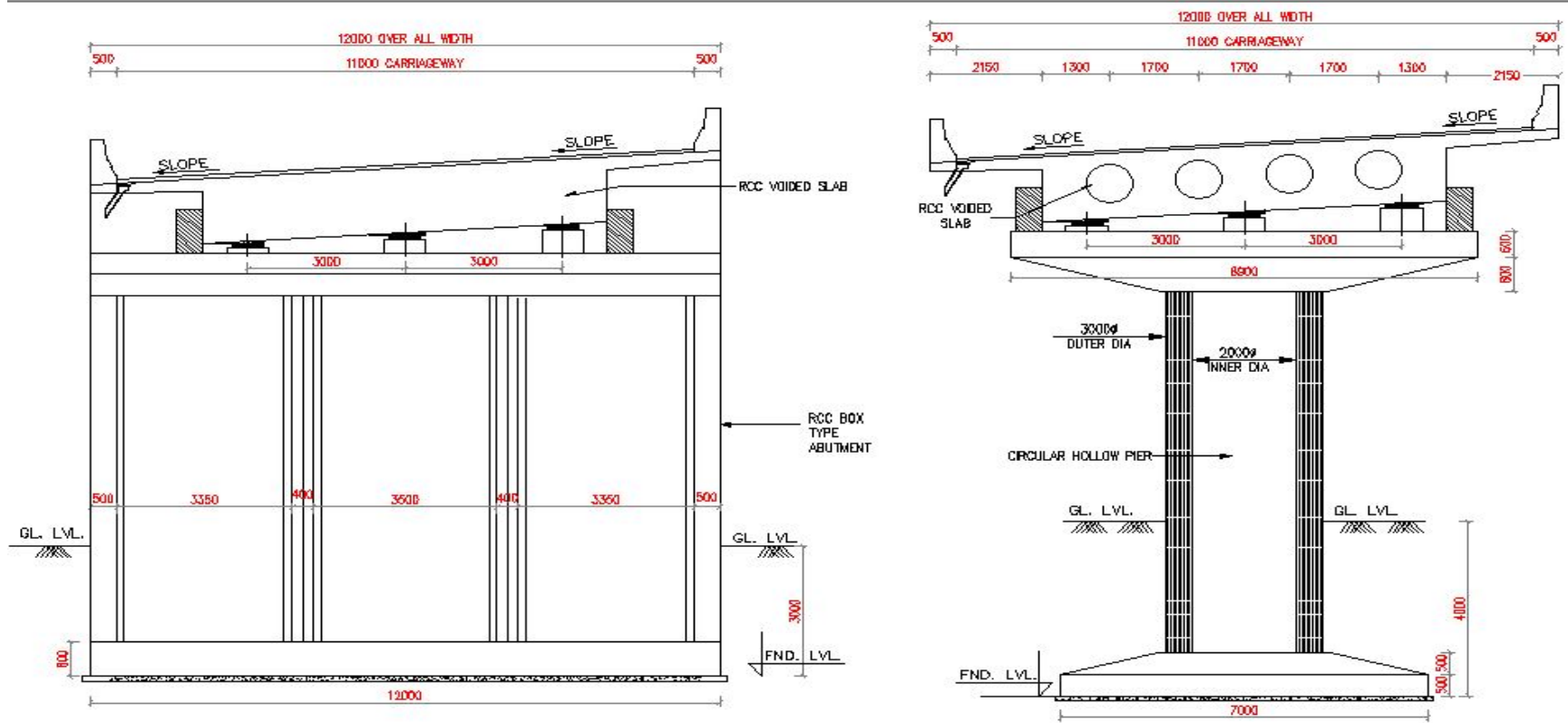

TCS-IX
TYPICAL CROSS SECTION FOR ELEVATED STRUCTURE
(Including Box Abutment Length)

Construction and upgradation of existing road to 2-lane with Paved shoulder from km. 20.340 (Rongli Bazaar) to km. 26.588 (Rongli Bypass End) and upgradation of existing road at km 20.600 & km 26.400 for length of 0.520 km & 0.554 km of Rhenok – Menla spur (NH-717B) Package-II A on EPC Basis under SARDP-NE Phase ‘A’ in the State of Sikkim.

Schedule - E
(See Clauses 2.1 and 14.2)

Maintenance Requirements

1. Maintenance Requirements

- (i) The Contractor shall, at all times maintain the Project Highway in accordance with the provisions of this Agreement, Applicable Laws and Applicable Permits.
- (ii) The Contractor shall repair or rectify any Defect or deficiency set forth in Paragraph 2 of this Schedule-E within the time limit specified therein and any failure in this behalf shall constitute non-fulfillment of the Maintenance obligations by the Contractor. Upon occurrence of any breach hereunder, the Authority shall be entitled to effect reduction in monthly lump sum payment as set forth in Clause 14.6 of this Agreement, without prejudice to the rights of the Authority under this Agreement, including Termination thereof.
- (iii) All Materials, works and construction operations shall conform to the MORTH Specifications for Road and Bridge Works, and the relevant IRC publications. Where the specifications for a work are not given, Good Industry Practice shall be adopted.

[Specify all the relevant documents]

2. Repair/rectification of Defects and deficiencies

The obligations of the Contractor in respect of Maintenance Requirements shall include repair and rectification of the Defects and deficiencies specified in Annex -I of this Schedule-E within the time limit set forth therein.

3. Other Defects and deficiencies

In respect of any Defect or deficiency not specified in Annex -I of this Schedule-E, the Authority's Engineer may, in conformity with Good Industry Practice, specify the permissible limit of deviation or deterioration with reference to the Specifications and Standards, and any deviation or deterioration beyond the permissible limit shall be repaired or rectified by the Contractor within the time limit specified by the Authority's Engineer.

4. Extension of time limit

Notwithstanding anything to the contrary specified in this Schedule-E, if the nature and extent of any Defect or deficiency justifies more time for its repair or rectification than the time specified herein, the Contractor shall be entitled to additional time in conformity with Good Industry Practice. Such additional time shall be determined by the Authority's Engineer and conveyed to the Contractor and the Authority with reasons thereof.

5. Emergency repairs/restoration

Notwithstanding anything to the contrary contained in this Schedule-E, if any Defect, deficiency or deterioration in the Project Highway poses a hazard to safety or risk of damage to property, the Contractor shall promptly take all reasonable measures for eliminating or minimizing such danger.

6. Daily inspection by the Contractor

The Contractor shall, through its engineer, undertake a daily visual inspection of the Project Highway and maintain a record thereof in a register to be kept in such form and manner as the

Authority's Engineer may specify. Such record shall be kept in safe custody of the Contractor and shall be open to inspection by the Authority and the Authority's Engineer at any time during office hours.

7. Pre-monsoon inspection / Post-monsoon inspection

The Contractor shall carry out a detailed pre-monsoon inspection of all bridges, culverts and drainage system before [1st June] every year in accordance with the guidelines contained in IRC: SP35. Report of this inspection together with details of proposed maintenance works as required on the basis of this inspection shall be sent to the Authority's Engineer before the [10th June] every year. The Contractor shall complete the required repairs before the onset of the monsoon and send to the Authority's Engineer a compliance report. Post monsoon inspection shall be done by the [30th September] and the inspection report together with details of any damages observed and proposed action to remedy the same shall be sent to the Authority's Engineer.

8. Repairs on account of natural calamities

All damages occurring to the Project Highway on account of a Force Majeure Event or wilful default or neglect of the Authority shall be undertaken by the Authority at its own cost. The Authority may instruct the Contractor to undertake the repairs at the rates agreed between the Parties.

Annex -I
(Schedule-E)

Annex –I Repair/rectification of Defects and deficiencies

The Contractor shall repair and rectify the Defects and deficiencies specified in this Annex-I of Schedule-E within the time limit set forth in the table below.

Table -1: Maintenance Criteria for Pavements:

Asset Type	Performance Parameter	Level of Service (LOS)		Frequency of Inspection	Tools/ Equipment	Standards and References for Inspection and Data Analysis	Time limit for Rectification/ Repair	Maintenance Specifications	
		Desirable	Acceptable						
Flexible Pavement (Pavement of MCW, Service Road, approaches of Grade structure, approaches of connecting roads, slip roads, lay byes etc. as applicable)	Potholes	Nil	< 0.1 % of area and subject to limit of 10 mm in depth	Daily	Length Measurement Unit like Scale, Tape, odometer etc.	IRC 82: 2015 and Distress Identification Manual for Long Term Pavement Performance Program, FHWA 2003 (http://www.tfrc.com/pavement/ltpp/reports/03031/)	24-48 hours	MORT&H Specification 3004.2	
	Cracking	Nil	< 5 % subject to limit of 0.5 sqm for any 50 m length	Daily			7-15 days	MORT&H Specification 3004.3	
	Rutting	Nil	< 5 mm	Daily	Straight Edge		15 -30 days	MORT&H Specification 3004.2	
	Corrugations and Shoving	Nil	< 0.1 % of area	Daily	Length Measurement Unit like Scale, Tape, odometer etc.		2-7 days	IRC:82-2015	
	Bleeding	Nil	< 1 % of area	Daily			3-7 days	MORT&H Specification 3004.4	
	Ravelling/ Stripping	Nil	< 1 % of area	Daily			7-15 days	IRC:82-2015 read with IRC SP 81	
	Edge Deformation/ Breaking	Nil	< 1 m for any 100 m section and width < 0.1 m at any location, restricted to 30 cm from the edge	Daily			7- 15 days	IRC:82-2015	
	Roughness BI	2000 mm/km	2400 mm/km	Bi-Annually	Class I Profilometer SCRIM (Sideway-force Coefficient Routine		Class I Profilometer : ASTM E950 (98) :2004 –Standard Test Method for measuring Longitudinal Profile of Travelled Surfaces with Accelerometer Established	180 days	IRC:82-2015
	Skid Number	60SN	50SN	Bi-Annually			180 days	BS: 7941-1: 2006	
	Pavement Condition	3	2.1	Bi-Annually			180 days	IRC:82-2015	

Construction and upgradation of existing road to 2-lane with Paved shoulder from km. 20.340 (Rongli Bazzar) to km. 26.588 (Rongli Bypass End) and upgradation of existing road at km 20.600 & km 26.400 for length of 0.520 km & 0.554 km of Rhenok – Menla spur (NH-717B) Package-II A on EPC Basis under SARDP-NE Phase ‘A’ in the State of Sikkim.

Asset Type	Performance Parameter	Level of Service (LOS)		Frequency of Inspection	Tools/ Equipment	Standards and References for Inspection and Data Analysis	Time limit for Rectification/ Repair	Maintenance Specifications											
		Desirable	Acceptable																
	Index				Investigation Machine or equivalent)	Inertial Profiling Reference ASTM E1656 -94: 2000-Standard Guide for Classification of Automatic Pavement Condition Survey Equipment													
	Other Pavement Distresses			Bi-Annually				2-7 days	IRC:82-2015										
	Deflection/ Remaining Life			Annually	Falling Weight Deflectometer	IRC 115: 2014	180 days	IRC:115-2014											
Rigid Pavement (Pavement of MCW, Service Road, Grade structure, approaches of connecting roads, slip roads, lay byes etc. as applicable)	Roughness BI	2200mm/km	2400mm/km	Bi-Annually	Class I Profilometer	ASTM E950 (98) :2004 and ASTM E1656 -94: 2000	180 days	IRC:SP:83-2008											
	Skid	Skid Resistance no. at different speed of vehicles <table border="1"> <thead> <tr> <th>Minimum SN</th> <th>Traffic Speed (Km/h)</th> </tr> </thead> <tbody> <tr> <td>36</td> <td>50</td> </tr> <tr> <td>33</td> <td>65</td> </tr> <tr> <td>32</td> <td>80</td> </tr> <tr> <td>31</td> <td>95</td> </tr> <tr> <td>31</td> <td>110</td> </tr> </tbody> </table>		Minimum SN	Traffic Speed (Km/h)	36	50	33	65	32	80	31	95	31	110	Bi-Annually	SCRIM (Sideway-force Coefficient Routine Investigation Machine or equivalent)	IRC:SP:83-2008	180 days
Minimum SN	Traffic Speed (Km/h)																		
36	50																		
33	65																		
32	80																		
31	95																		
31	110																		
Embankment/ Slope	Edge drop at shoulders	Nil	40mm	Daily	Length Measurement Unit like Scale, Tape, odometer etc.	IRC	7-15 days	MORT&H Specification 408.4											
	Slope of camber/cross fall	Nil	<2% variation in prescribed slope of camber /cross fall	Daily			7-15 days	MORT&H Specification 408.4											
	Embankment Slopes	Nil	<15 % variation in prescribe side slope	Daily			7-15 days	MORT&H Specification 408.4											

Construction and upgradation of existing road to 2-lane with Paved shoulder from km. 20.340 (Rongli Bazzar) to km. 26.588 (Rongli Bypass End) and upgradation of existing road at km 20.600 & km 26.400 for length of 0.520 km & 0.554 km of Rhenok – Menla spur (NH-717B) Package-II A on EPC Basis under SARDP-NE Phase ‘A’ in the State of Sikkim.

Asset Type	Performance Parameter	Level of Service (LOS)		Frequency of Inspection	Tools/ Equipment	Standards and References for Inspection and Data Analysis	Time limit for Rectification/ Repair	Maintenance Specifications
		Desirable	Acceptable					
	Embankment Protection	Nil	Nil	Daily	NA		7-15 days	MORT&H Specification
	Rain Cuts/ Gullies in slope	Nil	Nil	Daily Specially During Rainy Season	NA		7-15 days	MORT&H Specification

In addition to the above performance criterion, the contractor shall strictly maintain the rigid pavements as per requirements in the following table

Table -2: **Maintenance Criteria for Rigid Pavements:**

Sr. No.	Type of Distress	Measured Parameter	Degree of Severity	Assessment Rating	Repair Action	
					For the case $d < D/2$	For the case $d > D/2$
CRACKING						
1	Single Discrete Cracks Not intersecting with any joint	w = width of crack L = length of crack d = depth of crack D = depth of slab	0	Nil, not discernible	No Action	Not applicable
			1	w < 0.2 mm. hair cracks		
			2	w = 0.2 - 0.5 mm, discernible from slow-moving car	Seal without delay	Seal, and stitch if L > 1m. Within 7days
			3	w = 0.5 - 1.5 mm, discernible from fast-moving car		
			4	w = 1.5 - 3.0 mm	Seal, and stitch if L > 1 m. Within 7 days	Staple or Dowel Bar Retrofit, FDR for affected portion. Within 15days
5	w > 3 mm.					
2	Single Transverse (or Diagonal) Crack intersecting with one or more joints	w = width of crack L = length of crack d = depth of crack D = depth of slab	0	Nil, not discernible	No Action	
			1	w < 0.2 mm, hair cracks	Route and seal with epoxy. Within 7 days	Staple or Dowel Bar Retrofit. Within 15days
			2	w = 0.2 - 0.5 mm, discernible from slow vehicle		
			3	w = 0.5 - 3.0 mm, discernible from fast vehicle	Route, seal and stitch, if L > 1 m. Within 7 days	

Construction and upgradation of existing road to 2-lane with Paved shoulder from km. 20.340 (Rongli Bazaar) to km. 26.588 (Rongli Bypass End) and upgradation of existing road at km 20.600 & km 26.400 for length of 0.520 km & 0.554 km of Rhenok – Menla spur (NH-717B) Package-II A on EPC Basis under SARDP-NE Phase 'A' in the State of Sikkim.

Sr. No.	Type of Distress	Measured Parameter	Degree of Severity	Assessment Rating	Repair Action	
					For the case $d < D/2$	For the case $d > D/2$
			4	w = 3.0 - 6.0 mm	Dowel Bar Retrofit. Within 15 days	Full Depth Repair Dismantle and reconstruct affected.
			5	w > 6 mm, usually associated with spalling, and/or slab rocking under traffic	Not Applicable, as it may be full depth	Portion with norms and specifications - See Para 5.5 & 9.2 Within 15days
3	Single Longitudinal Crack intersecting with one or more joints	w = width of crack L = length of crack d = depth of crack D = depth of slab	0	Nil, not discernible	No Action	
			1	w < 0.5 mm, discernible from slow moving vehicle	Seal with epoxy, if L > 1 m. Within 7 days	Staple or dowel bar retrofit. Within 15days
			2	w = 0.5 - 3.0 mm, discernible from fast vehicle	Route seal and stitch, if L > 1 m. Within 15 days	-
			3	w = 3.0 - 6.0 mm	Staple, if L > 1 m. Within 15 days	Partial Depth Repair with stapling. Within 15 days
			4	w = 6.0 - 12.0 mm, usually associated with spalling	Not Applicable, as it may be full depth	Full Depth Repair Dismantle and reconstruct affected portion as per norms and specifications - See Para 5.6.4 Within 15 days
			5	w > 12 mm, usually associated with spalling, and/or slab rocking under traffic		
4	Multiple Cracks intersecting with one or more joints	w = width of crack	0	Nil, not discernible	No Action	
			1	w < 0.2 mm, hair cracks	Seal, and stitch if L > 1 m. Within 15 days	-
			2	w = 0.2 - 0.5 mm. discernible from slow vehicle		
			3	w = 0.5 - 3.0 mm, discernible from fast vehicle	Full depth repair within 15 days	Dismantle, Reinststate sub-base, Reconstruct whole slab as per specifications within 30 days
			4	w = 3.0 - 6.0 mm panel broken into 2 or 3 pieces		
			5	w > 6 mm and/or panel broken into more		

Construction and upgradation of existing road to 2-lane with Paved shoulder from km. 20.340 (Rongli Bazzar) to km. 26.588 (Rongli Bypass End) and upgradation of existing road at km 20.600 & km 26.400 for length of 0.520 km & 0.554 km of Rhenok – Menla spur (NH-717B) Package-II A on EPC Basis under SARDP-NE Phase 'A' in the State of Sikkim.

Sr. No.	Type of Distress	Measured Parameter	Degree of Severity	Assessment Rating	Repair Action	
					For the case $d < D/2$	For the case $d > D/2$
5	Corner Break	w = width of crack L = length of crack	0	than 4 pieces Nil, not discernible	No Action	-
			1	w < 0.5 mm; only 1 corner broken	Seal with low viscosity epoxy to secure broken parts Within 7 days	Seal with epoxy seal with epoxy Within 7days
			2	w < 1.5 mm; L < 0.6 m, only one corner broken	Partial Depth (Refer Figure 8.3 of IRC:SP: 83-2008) Within 15 days	Full depth repair
			3	w < 1.5 mm; L < 0.6 m, two corners broken		Reinstate sub-base, and reconstruct the slab as per norms and specifications within 30days
			4	w > 1.5 mm; L > 0.6 m or three corners broken		
			5	three or four corners broken		
6	Punchout (Applicable to Continuous Reinforced Concrete Pavement (CRCP) only)	w = width of crack L = length (m/m ²)	0	Nil, not discernible	No Action	No Action
			1	w < 0.5 mm; L < 3 m/m ²	Not Applicable, as it may be full depth	Seal with low viscosity epoxy to secure broken parts. Within 15days
			2	either w > 0.5 mm or L < 3 m/m ²		
			3	w > 1.5 mm and L < 3 m/m ²		
			4	w > 3 mm, L < 3 m/m ² and deformation		Full depth repair - Cut out and replace damaged area taking care not to damage reinforcement. Within 30days
			5	w > 3 mm, L > 3 m/m ² and deformation		
Surface Defects						
7	Ravelling or Honeycomb type surface	r = area damaged surface/total surface of slab (%) h = maximum depth of damage	0	Nil, not discernible	Short Term No action.	Long Term Not Applicable
			1	r < 2 %	Local repair of areas damaged and liable to be damaged. Within 15 days	
			2	r = 2 - 10 %	Bonded Inlay, 2 or 3 slabs if affecting.	
			3	r = 10-25%		
			4	r = 25 - 50 %		

Construction and upgradation of existing road to 2-lane with Paved shoulder from km. 20.340 (Rongli Bazzar) to km. 26.588 (Rongli Bypass End) and upgradation of existing road at km 20.600 & km 26.400 for length of 0.520 km & 0.554 km of Rhenok – Menla spur (NH-717B) Package-II A on EPC Basis under SARDP-NE Phase ‘A’ in the State of Sikkim.

Sr. No.	Type of Distress	Measured Parameter	Degree of Severity	Assessment Rating	Repair Action	
					For the case $d < D/2$	For the case $d > D/2$
			5	$r > 50\%$ and $h > 25$ mm	Within 30 days Reconstruct slabs, 4 or more slabs if affecting. Within 30 days	
8	Scaling	r = damaged surface/total surface of slab (%) h = maximum depth of damage	0	Nil, not discernible	Short Term No action.	Not Applicable
			1	$r < 2\%$	Local repair of areas damaged and liable to be damaged. Within 7days	
			2	$r = 2 - 10\%$	Bonded Inlay within 15 days	
			4	$r = 20 - 30\%$	Reconstruct slab within 30 days	
			5	$r > 30\%$ and $h > 25$ mm		
9	Polished Surface/Glazing	t = texture depth, sand patch test	0		No action.	Not Applicable
			1	$t > 1$ mm		
			2	$t = 1 - 0.6$ mm	Monitor rate of deterioration	
			3	$t = 0.6 - 0.3$ mm		
			4	$t = 0.3 - 0.1$ mm		
10	Popout (Small Hole), Pothole Refer Para 8.4	n = number/m ² d = diameter h = maximum depth	0	$d < 50$ mm; $h < 25$ mm; $n < 1$ per 5 m ²	No action.	Not Applicable
			1	$d = 50 - 100$ mm; $h < 50$ mm; $n < 1$ per 5 m ²	Partial depth repair 65 mm deep. Within 15 days	
			2	$d = 50 - 100$ mm; $h > 50$ mm; $n < 1$ per 5 m ²	Partial depth repair 110mm i.e. 10 mm more than the depth of the hole.	
			3	$d = 100 - 300$ mm; $h < 100$ mm $n < 1$ per 5 m ²		
			4	$d = 100 - 300$ mm; $h > 100$ mm; $n < 1$ per 5 m ²		

Construction and upgradation of existing road to 2-lane with Paved shoulder from km. 20.340 (Rongli Bazzar) to km. 26.588 (Rongli Bypass End) and upgradation of existing road at km 20.600 & km 26.400 for length of 0.520 km & 0.554 km of Rhenok – Menla spur (NH-717B) Package-II A on EPC Basis under SARDP-NE Phase ‘A’ in the State of Sikkim.

Sr. No.	Type of Distress	Measured Parameter	Degree of Severity	Assessment Rating	Repair Action	
					For the case $d < D/2$	For the case $d > D/2$
			5	$d > 300$ mm; $h > 100$ mm: $n > 1$ per 5 m ²	Within 30 days Full depth repair. Within 30 days	
Joint Defects						
11	Joint Seal Defects	loss or damage L = Length as % total joint length	0	Difficult to discern.	Short Term No action.	Long Term Not Applicable
			1	Discernible, $L < 25\%$ but of little immediate consequence with regard to ingress of water or trapping incompressible material.	Clean joint, inspect later.	
			3	Notable. $L > 25\%$ insufficient protection against ingress of water and trapping incompressible material.	Clean and reapply sealant in selected locations. Within 7 days	
			5	Severe; $w > 3$ mm negligible protection against ingress of water and trapping incompressible material.	Clean, widen and reseal the joint. Within 7 days	
12	Spalling of Joints	w = width on either side of the joint L = length of spalled portion (as % joint length)	0	Nil, not discernible	No action.	Not Applicable
			1	$w < 10$ mm	Apply low viscosity epoxy resin/ mortar in cracked portion. Within 7 days	
			2	$w = 10 - 20$ mm, $L < 25\%$	Partial Depth Repair. Within 15 days	
			3	$w = 20 - 40$ mm, $L > 25\%$	30 - 50 mm deep, $h = w + 20\%$ of w , within 30 days	
			4	$w = 40 - 80$ mm, $L > 25\%$	50 - 100 mm deep repair. $H = w + 20\%$ of w . Within 30 days	
			5	$w > 80$ mm, and $L > 25\%$		
13	Faulting (or Stepping) in Cracks or Joints	f = difference of level	0	not discernible, < 1 mm	No action.	No action. Replace the slab as appropriate.
			1	$f < 3$ mm		
			2	$f = 3 - 6$ mm	Determine cause and observe, take action for	

Construction and upgradation of existing road to 2-lane with Paved shoulder from km. 20.340 (Rongli Bazzar) to km. 26.588 (Rongli Bypass End) and upgradation of existing road at km 20.600 & km 26.400 for length of 0.520 km & 0.554 km of Rhenok – Menla spur (NH-717B) Package-II A on EPC Basis under SARDP-NE Phase 'A' in the State of Sikkim.

Sr. No.	Type of Distress	Measured Parameter	Degree of Severity	Assessment Rating	Repair Action	
					For the case $d < D/2$	For the case $d > D/2$
					diamond grinding	Within 30days
			3	$f = 6 - 12 \text{ mm}$	Diamond Grinding	
			4	$f = 12 - 18 \text{ mm}$	Raise sunken slab.	
			5	$f > 18 \text{ mm}$	Strengthen subgrade and sub-base by grouting and raising sunken slab	Replace the slab as appropriate. Within 30days
14	Blowup or Buckling	h = vertical displacement from normal profile	0	Nil, not discernible	Short Term	Long Term
			1	$h < 6 \text{ mm}$	No Action	
			2	$h = 6 - 12 \text{ mm}$	Install Signs to Warn Traffic within 7 days	
			3	$h = 12 - 25 \text{ mm}$		
			4	$h > 25 \text{ mm}$	Full Depth Repair. Within 30 days	
			5	shattered slabs, ie 4 or more pieces	Replace broken slabs. Within 30 days	
15	Depression	h = negative vertical displacement from normal profile L = length	0	Not discernible, $h < 5 \text{ mm}$	No action.	Not Applicable
			1	$h = 5 - 15 \text{ mm}$		
			2	$h = 15 - 30 \text{ mm}$, Nos <20% joints	Install Signs to Warn Traffic within 7 days	
			3	$h = 30 - 50 \text{ mm}$		
			4	$h > 50 \text{ mm}$ or > 20% joints	Strengthen sub-grade. Reinstate pavement at normal level if $L < 20 \text{ m}$. Within 30 days	
			5	$h > 100 \text{ mm}$		
16	Heave	h = positive vertical displacement from normal profile. L = length	0	Not discernible. $h < 5 \text{ mm}$	Short Term	Long Term
			1	$h = 5 - 15 \text{ mm}$	No action.	
			2	$h = 15 - 30 \text{ mm}$, Nos <20% joints	Install Signs to Warn Traffic within 7 days	
			3	$h = 30 - 50 \text{ mm}$		
			4	$h > 50 \text{ mm}$ or > 20% joints	Stabilise subgrade.	

Construction and upgradation of existing road to 2-lane with Paved shoulder from km. 20.340 (Rongli Bazzar) to km. 26.588 (Rongli Bypass End) and upgradation of existing road at km 20.600 & km 26.400 for length of 0.520 km & 0.554 km of Rhenok – Menla spur (NH-717B) Package-II A on EPC Basis under SARDP-NE Phase ‘A’ in the State of Sikkim.

Sr. No.	Type of Distress	Measured Parameter	Degree of Severity	Assessment Rating	Repair Action	
					For the case $d < D/2$	For the case $d > D/2$
17	Bump	h = vertical displacement from normal profile	5	$h > 100$ mm	Reinstate pavement at normal level if length < 20 m. Within 30 days	
			0	$h < 4$ mm	No action	
			1	$h = 4 - 7$ mm	Grind, in case of new construction within 7 days	Construction Limit for New Construction.
			3	$h = 7 - 15$ mm	Grind, in case of ongoing Maintenance within 15 days	Replace in case of new construction. Within 30days
			5	$h > 15$ mm	Full Depth Repair. Within 30 days	Full Depth Repair. Within 30days
18	Lane to Shoulder Dropoff	f = difference of level	0	Nil, not discernible < 3mm	Short Term No action.	Long Term
			1	$f = 3 - 10$ mm	Spot repair of shoulder within 7 days	
			2	$f = 10 - 25$ mm		
			3	$f = 25 - 50$ mm	Fill up shoulder within 7 days	For any 100 m stretch Reconstruct shoulder, if affecting 25% or more of stretch. Within 30days
			4	$f = 50 - 75$ mm		
			5	$f > 75$ mm		
Drainage						
19	Pumping	quantity of fines and water expelled through open joints and cracks Nos	0	not discernible	No Action	
			1 to 2	slight/ occasional Nos < 10%	Repair cracks and joints Without delay.	Inspect and repair sub-drainage at distressed sections and upstream.
			3 to 4	appreciable/ Frequent 10 - 25%	Lift or jack slab within 30 days.	
		Nos/100 m stretch	5	abundant, crack development > 25%	Repair distressed pavement sections. Strengthen subgrade and subbase. Replace	

Construction and upgradation of existing road to 2-lane with Paved shoulder from km. 20.340 (Rongli Bazzar) to km. 26.588 (Rongli Bypass End) and upgradation of existing road at km 20.600 & km 26.400 for length of 0.520 km & 0.554 km of Rhenok – Menla spur (NH-717B) Package-II A on EPC Basis under SARDP-NE Phase ‘A’ in the State of Sikkim.

Sr. No.	Type of Distress	Measured Parameter	Degree of Severity	Assessment Rating	Repair Action	
					For the case $d < D/2$	For the case $d > D/2$
					slab. Within 30 days	
20	Ponding	Ponding on slabs due to blockage of drains	0-2	No discernible problem	No action.	
			3 to 4	Blockages observed in drains, but water flowing	Clean drains etc within 7 days, Follow up	Action required to stop water damaging foundation within 30 days.
			5	Ponding, accumulation of water observed	-do-	

Construction and upgradation of existing road to 2-lane with Paved shoulder from km. 20.340 (Rongli Bazzar) to km. 26.588 (Rongli Bypass End) and upgradation of existing road at km 20.600 & km 26.400 for length of 0.520 km & 0.554 km of Rhenok – Menla spur (NH-717B) Package-II A on EPC Basis under SARDP-NE Phase ‘A’ in the State of Sikkim.

Table -3: Maintenance Criteria for Safety Related Items and Other Furniture Items:

Asset Type	Performance Parameter	Level of Service (LOS)			Frequency of Measurement	Testing Method	Recommended Remedial measures	Time limit for Rectification	Specifications and Standards
Highway	Availability of Safe Sight Distance	As per IRC SP: 84-2014, a minimum of safe stopping sight distance shall be available throughout.			Monthly	Manual Measurements with Odometer along with video/ image backup	Removal of obstruction within 24 hours, in case of sight line affected by temporary objects such as trees, temporary encroachments. In case of permanent structure or design deficiency: Removal of obstruction/improvement of deficiency at the earliest Speed Restriction boards and suitable traffic calming measures such as transverse bar marking, blinkers, etc. shall be applied during the period of rectification.		IRC:SP 84-2014
		Design Speed, kmph	Desirable Minimum Sight Distance (m)	Safe Stopping Sight Distance (m)					
		100	360	180					
		80	260	130					
Pavement Marking	Wear	<70% of marking remaining			Bi-Annually	Visual Assessment as per Annexure-F of IRC:35-2015	Re - painting	Cat-1 Defect – within 24 hours Cat-2 Defect - within 2 months	IRC:35-2015
	Day time Visibility	During expected life Service Time Cement Road - 130mcd/m ² /lux Bituminous Road - 100mcd/m ² /lux			Monthly	As per Annexure-D of IRC:35-2015	Re - painting	Cat-1 Defect – within 24 hours Cat-2 Defect – within 2 months	IRC:35-2015
	Night Time Visibility	<u>Initial and Minimum Performance for Dry Retro reflectivity during night time:</u> Design Speed (RL) Retro Reflectivity (mcd/m ² /lux)			Bi-Annually	As per Annexure-E of IRC:35-2015	Re - painting	Cat-1 Defect – within 24 hours Cat-2 Defect – within 2 months	IRC:35-2015

Construction and upgradation of existing road to 2-lane with Paved shoulder from km. 20.340 (Rongli Bazaar) to km. 26.588 (Rongli Bypass End) and upgradation of existing road at km 20.600 & km 26.400 for length of 0.520 km & 0.554 km of Rhenok – Menla spur (NH-717B) Package-II A on EPC Basis under SARDP-NE Phase 'A' in the State of Sikkim.

Asset Type	Performance Parameter	Level of Service (LOS)			Frequency of Measurement	Testing Method	Recommended Remedial measures	Time limit for Rectification	Specifications and Standards
			Initial (7 days)	Minimum Threshold level (TL) & warranty period required up to 2 years					
		Up to 65	200	80					
		65 - 100	250	120					
		Above 100	350	150					
		<u>Initial and Minimum Performance for Night Visibility under wet condition (Retro reflectivity):</u> Initial 7 days Retro reflectivity: 100 mcd/m ² /lux Minimum Threshold Level: 50 mcd/m ² /lux							
	Skid Resistance	Initial and Minimum performance for Skid Resistance: Initial (7days): 55BPN Min. Threshold: 44BPN *Note: shall be considered under urban/city traffic condition encompassing the locations like pedestrian crossings, bus bay, bus stop, cycle track intersection delineation, transverse bar markings etc			Bi-Annually	As per Annexure-G of IRC:35-2015	Within 24 hours	IRC:35-2015	
Road Signs	Shape and Position	Shape and Position as per IRC:67-2012. Signboard should be clearly visible for the design speed of the section.			Daily	Visual with video/image backup	Improvement of shape, in case if shape is damaged. Relocation as per	48 hours in case of Mandatory Signs, Cautionary and Informatory Signs (Single and Dual post signs)	IRC:67-2012

Construction and upgradation of existing road to 2-lane with Paved shoulder from km. 20.340 (Rongli Bazzar) to km. 26.588 (Rongli Bypass End) and upgradation of existing road at km 20.600 & km 26.400 for length of 0.520 km & 0.554 km of Rhenok – Menla spur (NH-717B) Package-II A on EPC Basis under SARDP-NE Phase ‘A’ in the State of Sikkim.

Asset Type	Performance Parameter	Level of Service (LOS)	Frequency of Measurement	Testing Method	Recommended Remedial measures	Time limit for Rectification	Specifications and Standards
					requirement	15 Days in case of Gantry/Cantilever Sign boards	
	Retro reflectivity	As per specifications in IRC:67-2012	Bi-Annually	Testing of each signboard using Retro Reflectivity Measuring Device. In accordance with ASTM D 4956-09.	Change of signboard	48 hours in case of Mandatory Signs, Cautionary and Informatory Signs (Single and Dual post signs) 1 Month in case of Gantry/Cantilever Sign boards	RC:67-2012
Kerb	Kerb Height	As per IRC 86:1983 depending upon type of Kerb	Bi-Annually	Use of distance measuring tape	Raising Kerb Height	Within 1 Month	RC 86:1983
	Kerb Painting	<u>Functionality</u> : Functioning of Kerb painting as intended	Daily	Visual with video/image backup	Kerb Repainting	Within 7-days	RC 35:2015
Other Road Furniture	Reflective Pavement Markers (Road Studs)	Numbers and Functionality as per specifications in IRC:SP:84-2014 and IRC:35-2015, unless specified in Schedule-B.	Daily	Counting	New Installation	Within 2 months	IRC:SP:84-2014, IRC:35-2015
	Pedestrian Guardrail	<u>Functionality</u> : Functioning of guardrail as intended	Daily	Visual with video/image backup	Rectification	Within 15 days	IRC:SP:84-2014
	Traffic Safety Barriers	<u>Functionality</u> : Functioning of Safety Barriers as intended	Daily	Visual with video/image backup	Rectification	Within 7 days	IRC:SP:84-2014, IRC:119-2015
	End Treatment of Traffic	<u>Functionality</u> : Functioning of End Treatment as intended	Daily	Visual with video/image	Rectification	Within 7 days	IRC:SP:84-2014, IRC:119-

Construction and upgradation of existing road to 2-lane with Paved shoulder from km. 20.340 (Rongli Bazzar) to km. 26.588 (Rongli Bypass End) and upgradation of existing road at km 20.600 & km 26.400 for length of 0.520 km & 0.554 km of Rhenok – Menla spur (NH-717B) Package-II A on EPC Basis under SARDP-NE Phase ‘A’ in the State of Sikkim.

Asset Type	Performance Parameter	Level of Service (LOS)	Frequency of Measurement	Testing Method	Recommended Remedial measures	Time limit for Rectification	Specifications and Standards
	Safety Barriers			backup			2015
	Attenuators	<u>Functionality:</u> Functioning of Attenuators as intended	Daily	Visual with video/image backup	Rectification	Within 7 days	IRC:SP-2014, IRC:119-2015
	Guard Posts and Delineators	<u>Functionality:</u> Functioning of Guard Posts and Delineators as intended	Daily	Visual with video/image backup	Rectification	Within 15 days	IRC: 79 - 1981
	Overhead Sign Structure	Overhead sign structure shall be structurally adequate	Daily	Visual with video/image backup	Rectification	Within 15 days	IRC:67-2012
	Traffic Blinkers	<u>Functionality:</u> Functioning of Traffic Blinkers as intended	Daily	Visual with video/image backup	Rectification	Within 7 days	IRC:SP:84-2014
Highway Lighting System	Highway Lights	Illumination: Minimum 40 Lux illumination on the road surface	Daily	The illumination level shall be measured with luxmeter	Improvement in Lighting System	24 hours	IRC:SP:84-2014
		No major failure in the lighting system	Daily	-	Rectification of failure	24 hours	IRC:SP:84-2014
		No minor failure in the lighting system	Monthly	-	Rectification of failure	8 hours	IRC:SP:84-2014
	Toll Plaza Canopy Lights	Minimum 40 Lux illumination on the road surface	Daily	The illumination level shall be measured with luxmeter	Improvement in Lighting System	24 hours	IRC:SP:84-2014
		No major/minor failure in the lighting system	Daily	-	Rectification of failure	8 hours	IRC:SP:84-2014

Construction and upgradation of existing road to 2-lane with Paved shoulder from km. 20.340 (Rongli Bazaar) to km. 26.588 (Rongli Bypass End) and upgradation of existing road at km 20.600 & km 26.400 for length of 0.520 km & 0.554 km of Rhenok – Menla spur (NH-717B) Package-II A on EPC Basis under SARDP-NE Phase ‘A’ in the State of Sikkim.

Asset Type	Performance Parameter	Level of Service (LOS)	Frequency of Measurement	Testing Method	Recommended Remedial measures	Time limit for Rectification	Specifications and Standards
Trees and Plantation including median plantation	Obstruction in a minimum head-room of 5.5 m above carriageway or obstruction in visibility of road signs	No obstruction due to trees	Monthly	Visual with video/image backup	Removal of trees	Immediate	IRC:SP:84-2014
	Deterioration in health of trees and bushes	Health of plantation shall be as per requirement of specifications & instructions issued by Authority from time to time	Daily	Visual with video/image backup	Timely watering and treatment. Or Replacement of Trees and Bushes.	Within 90 days	IRC:SP:84-2014
	Vegetation affecting sight line and road structures	Sight line shall be free from obstruction by vegetation	Daily	Visual with video/image backup	Removal of Trees	Immediate	IRC:SP 84-2014
Rest Areas	Cleaning of toilets	-	Daily	-	-	Every 4 hours	
	Defects in electrical, water and sanitary installations	-	Daily	-	Rectification	24 hours	
Other Project Facilities and Approach roads	Damage or deterioration in Approach Roads, pedestrian facilities, truck lay-bys, bus-bays, bus-shelters, cattle crossings, Traffic Aid Posts, Medical Aid Posts and other works		Daily	-	Rectification	15 days	IRC:SP 84-2014

Construction and upgradation of existing road to 2-lane with Paved shoulder from km. 20.340 (Rongli Bazzar) to km. 26.588 (Rongli Bypass End) and upgradation of existing road at km 20.600 & km 26.400 for length of 0.520 km & 0.554 km of Rhenok – Menla spur (NH-717B) Package-II A on EPC Basis under SARDP-NE Phase ‘A’ in the State of Sikkim.

Asset Type	Performance Parameter	Level of Service (LOS)	Frequency of Measurement	Testing Method	Recommended Remedial measures	Time limit for Rectification	Specifications and Standards
Pipe/box/ slab culverts	Free waterway/ unobstructed flow section	85% of culvert normal flow area to available.	2 times in a year (before and after rainy season)	Inspection by Bridge Engineer as per IRC SP: 35-1990 and recording of depth of silting and area of vegetation.	Cleaning silt up soils and debris in culvert barrel after rainy season, removal of bushes and vegetation, U/s of barrel, under barrel and D/s of barrel before rainy season.	15 days before onset of monsoon and within 30 days after end of rainy season.	IRC 5-2015, IRC SP:40-1993 and IRC SP:13- 2004
	Leak-proof expansion joints if any	No leakage through expansion joints	Bi-Annually	Physical inspection of expansion joints as per IRC SP: 35-1990 if any, for leakage strains on walls at joints.	Fixing with sealant suitably	30 days or before onset of rains whichever comes earlier	IRC SP:40-1993 and IRC SP:69- 2011
	Structurally sound	Spalling of concrete not more than 0.25 sqm	Bi-Annually	Detailed inspection of all components of culvert as per IRC SP:35- 1990 and recording the defects	Repairs to spalling, cracking, delamination, rusting shall be followed as per IRC: SP: 40- 1993.	15 days	IRC SP 40- 1993 and MORTH Specifications clause 2800
		Delamination of concrete not more than 0.25 sq.m.					
Cracks wider than 0.3 mm not more than 1m aggregate length							
Protection works in good condition	Damaged of rough stone apron or bank revetment not more than 3 sqm, damage to solid apron (concrete apron) not more than 1 sqm	2 times in a year (before and after rainy season)	Condition survey as per IRC SP:35- 1990	Repairs to damaged aprons and pitching	30 days after defect observation or 2 weeks before onset of rainy season whichever is earlier.	IRC: SP 40- 1993 and IRC:SP:13- 2004.	

Construction and upgradation of existing road to 2-lane with Paved shoulder from km. 20.340 (Rongli Bazaar) to km. 26.588 (Rongli Bypass End) and upgradation of existing road at km 20.600 & km 26.400 for length of 0.520 km & 0.554 km of Rhenok – Menla spur (NH-717B) Package-II A on EPC Basis under SARDP-NE Phase ‘A’ in the State of Sikkim.

Asset Type	Performance Parameter	Level of Service (LOS)	Frequency of Measurement	Testing Method	Recommended Remedial measures	Time limit for Rectification	Specifications and Standards
Bridges including ROBs Flyover etc. as applicable	Riding quality or user comfort	No pothole in wearing coat on bridge deck	Daily	Visual inspection as per IRC SP:35-1990	Repairs to BC or wearing coat	15 days	MORT&H Specification 2811
	Bumps	No bump at expansion joint	Daily	Visual inspection as per IRC SP:35-1990	Repairs to BC on either side of expansion joints, profile correction on approach slab in case of settlement to approach embankment	15 days	MORT&H Specification 3004.2 & 2811.
Bridge - Super Structure	User safety (condition of crash barrier and guard rail)	No damaged or missing stretch of crash barrier or pedestrian hand railing	Daily	Visual inspection and detailed condition survey as per IRC SP: 35-1990.	Repairs and replacement of safety barriers as the case may be	3days	IRC: 5-1998, IRC SP: 84-2014 and IRC SP: 40-1993.
	Rusted reinforcement	Not more than 0.25 sqm	Bi-Annually	Detailed condition survey as per IRC SP: 35-1990 using Mobile Bridge Inspection Unit	All the corroded reinforcement shall need to be thoroughly cleaned from rusting and applied with anti-corrosive coating before carrying out the repairs to affected concrete portion with epoxy	15 days	IRC SP: 40-1993 and MORTH Specification 1600.
	Spalling of concrete	Not more than 0.50 sqm					
	Delamination	Not more than 0.50 sq.m					

Construction and upgradation of existing road to 2-lane with Paved shoulder from km. 20.340 (Rongli Bazzar) to km. 26.588 (Rongli Bypass End) and upgradation of existing road at km 20.600 & km 26.400 for length of 0.520 km & 0.554 km of Rhenok – Menla spur (NH-717B) Package-II A on EPC Basis under SARDP-NE Phase ‘A’ in the State of Sikkim.

Asset Type	Performance Parameter	Level of Service (LOS)	Frequency of Measurement	Testing Method	Recommended Remedial measures	Time limit for Rectification	Specifications and Standards
					mortar / concrete.		
	Cracks wider than 0.30 mm	Not more than 1m total length	Bi-Annually	Detailed condition survey as per IRC SP: 35-1990 using Mobile Bridge Inspection Unit	Grouting with epoxy mortar, investigating causes for cracks development and carry out necessary rehabilitation.	48 Hours	IRC SP: 40-1993 and MORTH Specification 2800.
	Rainwater seepage through deck slab	Leakage - nil	Quarterly	Detailed condition survey as per IRC SP: 35-1990 using Mobile Bridge Inspection Unit	Grouting of deck slab at leakage areas, waterproofing, repairs to drainage spouts	1 months	MORTH specifications 2600 & 2700.
	Deflection due to permanent loads and live loads	Within design limits.	Once in every 10 years for spans more than 40 m	Load test method	Carry out major rehabilitation works on bridge to retain original design loads capacity	6 months	IRC SP: 51-1999.
	Vibrations in bridge deck due to moving trucks	Frequency of vibrations shall not be more than 5 Hz	Once in every 5 years for spans more than 30m and every 10 years for spans between 15 to 30 m	Laser displacement sensors or laser vibro-meters	Strengthening of super structure	4 months	AASHTO LRFD specifications

Construction and upgradation of existing road to 2-lane with Paved shoulder from km. 20.340 (Rongli Bazzar) to km. 26.588 (Rongli Bypass End) and upgradation of existing road at km 20.600 & km 26.400 for length of 0.520 km & 0.554 km of Rhenok – Menla spur (NH-717B) Package-II A on EPC Basis under SARDP-NE Phase ‘A’ in the State of Sikkim.

Asset Type	Performance Parameter	Level of Service (LOS)	Frequency of Measurement	Testing Method	Recommended Remedial measures	Time limit for Rectification	Specifications and Standards
	Leakage in Expansion joints	No damage to elastomeric sealant compound in strip seal expansion joint, no leakage of rain water through expansion joint in case of buried and asphalt plug and copper strip joint.	Bi-Annually	Detailed condition survey as per IRC SP:35-1990 using Mobile Bridge Inspection Unit	Replace of seal in expansion joint	15 days	MORTH specifications 2600 and IRC SP: 40-1993.
	Debris and dust in strip seal expansion joint	No dust or debris in expansion joint gap.	Monthly	Detailed condition survey as per IRC SP:35-1990 using Mobile Bridge Inspection Unit	Cleaning of expansion joint gaps thoroughly	3 days	MORTH specifications 2600 and IRC SP: 40-1993.
	Drainage spouts	No down take pipe missing/broken below soffit of the deck slab. No silt, debris, clogging of drainage spout collection chamber.	Monthly	Detailed condition survey as per IRC SP: 35-1990 using Mobile Bridge Inspection Unit	Cleaning of drainage spouts thoroughly. Replacement of missing/broken down take pipes with a minimum pipe extension of 500mm below soffit of slab. Providing sealant around the drainage spout if any leakages observed.	3 days	MORTH specification 2700.
Bridge-substructure	Cracks/spalling of concrete/rusted steel	No cracks, spalling of concrete and rusted steel	Bi-Annually	Detailed condition survey as per IRC SP: 35-	All the corroded reinforcement shall need to be thoroughly	30 days	IRC SP: 40-1993 and MORTH specification

Construction and upgradation of existing road to 2-lane with Paved shoulder from km. 20.340 (Rongli Bazzar) to km. 26.588 (Rongli Bypass End) and upgradation of existing road at km 20.600 & km 26.400 for length of 0.520 km & 0.554 km of Rhenok – Menla spur (NH-717B) Package-II A on EPC Basis under SARDP-NE Phase ‘A’ in the State of Sikkim.

Asset Type	Performance Parameter	Level of Service (LOS)	Frequency of Measurement	Testing Method	Recommended Remedial measures	Time limit for Rectification	Specifications and Standards
				1990 using Mobile Bridge Inspection Unit	cleaned from rusting and applied with anti-corrosive coating before carrying out repairs to substructure by grouting/guniting and micro concreting depending on type of defect noticed		2800.
	Bearings	Delamination of bearing reinforcement not more than 5%, cracking or tearing of rubber not more than 2 locations per side, no rupture of reinforcement or rubber	Bi-Annually	Detailed condition survey as per IRC SP: 35-1990 using Mobile Bridge Inspection Unit	In case of failure of even one bearing on any pier/abutment, all the bearings on that pier/abutment shall be replaced, in order to get uniform load transfer on to bearings.	3 months	MORTH specification 2810 and IRC SP: 40-199.
Bridge Foundations	Scouring around foundations	Scouring shall not be lower than maximum scour level for the bridge	Bi-Annually	Condition survey and visual inspection as per IRC SP:35-1990 using Mobile Bridge	Suitable protection works around pier/abutment	1 month	IRC SP: 40-1993, IRC 83-2014, MORTH specification 2500

Construction and upgradation of existing road to 2-lane with Paved shoulder from km. 20.340 (Rongli Bazzar) to km. 26.588 (Rongli Bypass End) and upgradation of existing road at km 20.600 & km 26.400 for length of 0.520 km & 0.554 km of Rhenok – Menla spur (NH-717B) Package-II A on EPC Basis under SARDP-NE Phase ‘A’ in the State of Sikkim.

Asset Type	Performance Parameter	Level of Service (LOS)	Frequency of Measurement	Testing Method	Recommended Remedial measures	Time limit for Rectification	Specifications and Standards
				Inspection Unit. In case of doubt, use Underwater camera for inspection of deep wells in major Rivers.			
	Protection works in good condition	Damaged of rough stone apron or bank revetment not more than 3 sq.m, damage to solid apron (concrete apron) not more than 1 sq.m	2 times in a year (before and after rainy season)	Condition survey as per IRC SP:35-1990	Repairs to damaged aprons and pitching.	30 days after defect observation or 2 weeks before onset of rainy season whichever is earlier.	IRC: SP 40-1993 and IRC:SP:13-2004.
Note: Any Structure during the entire contract period which is found that does not complies with all requirements of this Table will be prepared, rehabilitated or even reconstructed under the scope of the contractor.							

Construction and upgradation of existing road to 2-lane with Paved shoulder from km. 20.340 (Rongli Bazzar) to km. 26.588 (Rongli Bypass End) and upgradation of existing road at km 20.600 & km 26.400 for length of 0.520 km & 0.554 km of Rhenok – Menla spur (NH-717B) Package-II A on EPC Basis under SARDP-NE Phase ‘A’ in the State of Sikkim.

Table 4: Maintenance Criteria for Structures and Culverts:

Table 5: Maintenance Criteria for Hill Roads

In addition to above, for hill roads the following provisions for maintenance is also to done.

Hill Roads		
(i)	Damage to Retaining wall/ Breast wall	7 (Seven) days
(ii)	Landslides requiring clearance	12 (Twelve) hours
(iii)	Snow requiring clearance	24 (Twenty Four) hours

Note: For all tables 1 to 5 above, latest BIS & IRC standards (even those not indicated herewith) along with MoRTH specifications shall be binding for all maintenance activities.

A. Flexible Pavement

Nature of Defect or deficiency		Time limit for repair/ rectification
(b) Granular earth shoulders, side slopes, drains and culverts		
(i)	Variation by more than 1 % in the prescribed slope of camber/cross fall (shall not be less than the camber on the main carriageway)	7 (seven) days
(ii)	Edge drop at shoulders exceeding 40 mm	7 (seven) days
(iii)	Variation by more than 15% in the prescribed side (embankment) slopes	30 (thirty) days
(iv)	Rain cuts/gullies in slope	7 (seven) days
(v)	Damage to or silting of culverts and side drains	7 (seven) days
(vi)	Desilting of drains in urban/semi- urban areas	24 (twenty four) hours
(vii)	Railing, parapets, crash barriers	7 (seven) days (Restore immediately if causing safety hazard)
(c) Road side furniture including road sign and pavement marking		
(i)	Damage to shape or position, poor visibility or loss of retro- reflectivity	48 (forty eight) hours
(ii)	Painting of km stone, railing, parapets, crash barriers	As and when required/ Once every year
(iii)	Damaged/missing signs road requiring replacement	7 (seven) days
(iv)	Damage to road mark ups	7 (seven) days
(d) Road lighting		
(i)	Any major failure of the system	24 (twenty four) hours
(ii)	Faults and minor failures	8 (eight) hours
(e) Trees and plantation		
(i)	Obstruction in a minimum head- room of 5 m above carriageway or obstruction in visibility of road signs	24 (twenty four)hours
(ii)	Removal of fallen trees from carriageway	4 (four) hours
(iii)	Deterioration in health of trees and bushes	Timely watering and treatment
(iv)	Trees and bushes requiring replacement	30 (thirty) days
(v)	Removal of vegetation affecting sight line and road structures	15 (fifteen) days
(f) Rest area		
(i)	Cleaning of toilets	Every 4 (four) hours
(ii)	Defects in electrical, water and sanitary installations	24 (twenty four) hours
(g) [Toll Plaza]		
(h) Other Project Facilities and Approach roads		

Nature of Defect or deficiency		Time limit for repair/ rectification
(i)	Damage in approach roads, pedestrian facilities, truck lay- byes, bus-bays, bus-shelters, cattle crossings, [Traffic Aid Posts, Medical Aid Posts] and service roads	15 (fifteen) days
(ii)	Damaged vehicles or debris on the road	4 (four) hours
(iii)	Malfunctioning of the mobile crane	4 (four) hours
Bridges		
(a) Superstructure		
(i)	Any damage, cracks, spalling/ scaling Temporary measures	within 48 (forty eight) hours
	Permanent measures	within 15 (fifteen) days or as specified by the Authority's Engineer
(b) Foundations		
(i)	Scouring and/or cavitation	15 (fifteen) days
(c) Piers, abutments, return walls and wing walls		
(i)	Cracks and damages including settlement and tilting, spalling, scaling	30 (thirty) days
(d) Bearings (metallic) of bridges		
(i)	Deformation, damages, tilting or shifting of bearings	15 (fifteen) days Greasing of metallic bearings once in a year
(e) Joints		
(i)	Malfunctioning of joints	15 (fifteen) days
(f) Other items		
(i)	Deforming of pads in elastomeric bearings	7 (seven) days
(ii)	Gathering of dirt in bearings and joints; or clogging of spouts, weep holes and vent-holes	3 (three) days
(iii)	Damage or deterioration in kerbs, parapets, handrails and crash barriers	3 (three) days (immediately within 24 hours if posing danger to safety)
(iv)	Rain-cuts or erosion of banks of the side slopes of approaches	7 (seven) days
(v)	Damage to wearing coat	15 (fifteen) days
(vi)	Damage or deterioration in approach slabs, pitching, apron, toes, floor or guide bunds	30 (thirty) days
(vii)	Growth of vegetation affecting the structure or obstructing the waterway	15 (fifteen) days
(g) Hill Roads		
(i)	Damage to retaining wall/breast wall	7 (seven) days
(ii)	Landslides requiring clearance	12 (twelve) hours
(iii)	Snow requiring clearance	24 (twenty four) hours

[Note: Where necessary, the Authority may modify the time limit for repair/rectification, or add to the nature of Defect or deficiency before issuing the bidding document, with the approval of the competent authority.]

Schedule - F

(See Clause 4.1 (vii)(a))

Applicable Permits

1. Applicable Permits

- (i) The Contractor shall obtain, as required under the Applicable Laws, the following Applicable Permits:
 - (a) Permission of the State Government for extraction of boulders from quarry;
 - (b) Permission of Village Panchayats and Pollution Control Board for installation of crushers;
 - (c) Licence for use of explosives;
 - (d) Permission of the State Government for drawing water from river/reservoir;
 - (e) Licence from inspector of factories or other competent Authority for setting up batching plant;
 - (f) Clearance of Pollution Control Board for setting up batching plant;
 - (g) Clearance of Village Panchayats and Pollution Control Board for setting up asphalt plant;
 - (h) Permission of Village Panchayats and State Government for borrow earth; and
 - (i) Any other permits or clearances required under Applicable Laws.
- (ii) Applicable Permits, as required, relating to environmental protection and conservation shall have been procured by the Authority in accordance with the provisions of this Agreement.

Schedule - G

(See Clauses 7.1 and 19.2)

Annex-I : Form of Bank Guarantee

(See Clause 7.1)

[Performance Security /Additional Performance Security]

[DG(RD)&SS,

Ministry of Road Transport & Highways Transport Bhawan, New Delhi]

WHEREAS:

- (A) _____ [name and address of contractor] (hereinafter called the "**Contractor**") and [name and address of the authority], (hereinafter called the "**Authority**") have entered into an agreement (hereinafter called the "**Agreement**") for the Construction and upgradation of existing road to 2-lane with Paved shoulder from km. 20.340 (Rongli Bazaar) to km. 26.588 (Rongli Bypass End) and upgradation of existing road at km 20.600 & km 26.400 for length of 0.520 km & 0.554 km of Rhenok – Menla spur (NH-717B) Package-II A in the State of Sikkim on EPC Basis under SARDP-NE Phase 'A' in the State of Sikkim.
- (B) The Agreement requires the Contractor to furnish a Performance Security for due and faithful performance of its obligations, under and in accordance with the Agreement, during the {Construction Period/ Defects Liability Period and Maintenance Period} (as defined in the Agreement) in a sum of Rs _____ cr. (Rupees _____ crore) (the "Guarantee Amount").
- (C) We, _____ through our branch at _____ (the "**Bank**") have agreed to furnish this bank guarantee (*hereinafter called the "Guarantee"*) by way of Performance Security.

NOW, THEREFORE, the Bank hereby, unconditionally and irrevocably, guarantees and affirms as follows:

1. The Bank hereby unconditionally and irrevocably guarantees the due and faithful performance of the Contractor's obligations during the {Construction Period/Defects Liability Period and Maintenance Period} under and in accordance with the Agreement, and agrees and undertakes to pay to the Authority, upon its mere first written demand, and without any demur, reservation, recourse, contest or protest, and without any reference to the Contractor, such sum or sums up to an aggregate sum of the Guarantee Amount as the Authority shall claim, without the Authority being required to prove or to show grounds or reasons for its demand and/or for the sum specified therein.
2. A letter from the Authority, under the hand of an officer not below the rank of [General Manager in the National Highways & Infrastructure Development Corporation Limited], that the Contractor has committed default in the due and faithful performance of all or any of its obligations under and in accordance with the Agreement shall be conclusive, final and binding on the Bank. The Bank further agrees that the Authority shall be the sole judge as to whether the Contractor is in default in due and faithful performance of its obligations during and under the Agreement and its decision that the Contractor is in default shall be final and binding on the Bank, notwithstanding any differences between the Authority and the Contractor, or any dispute between them pending before any court,

Construction and upgradation of existing road to 2-lane with Paved shoulder from km. 20.340 (Rongli Bazaar) to km. 26.588 (Rongli Bypass End) and upgradation of existing road at km 20.600 & km 26.400 for length of 0.520 km & 0.554 km of Rhenok – Menla spur (NH-717B) Package-II A on EPC Basis under SARDP-NE Phase 'A' in the State of Sikkim.

tribunal, arbitrators or any other authority or body, or by the discharge of the Contractor for any reason whatsoever.

3. In order to give effect to this Guarantee, the Authority shall be entitled to act as if the Bank were the principal debtor and any change in the constitution of the Contractor and/or the Bank, whether by their absorption with any other body or corporation or otherwise, shall not in any way or manner affect the liability or obligation of the Bank under this Guarantee.
4. It shall not be necessary, and the Bank hereby waives any necessity, for the Authority to proceed against the Contractor before presenting to the Bank its demand under this Guarantee.
5. The Authority shall have the liberty, without affecting in any manner the liability of the Bank under this Guarantee, to vary at any time, the terms and conditions of the Agreement or to extend the time or period for the compliance with, fulfillment and/ or performance of all or any of the obligations of the Contractor contained in the Agreement or to postpone for any time, and from time to time, any of the rights and powers exercisable by the Authority against the Contractor, and either to enforce or forbear from enforcing any of the terms and conditions contained in the Agreement and/or the securities available to the Authority, and the Bank shall not be released from its liability and obligation under these presents by any exercise by the Authority of the liberty with reference to the matters aforesaid or by reason of time being given to the Contractor or any other forbearance, indulgence, act or omission on the part of the Authority or of any other matter or thing whatsoever which under any law relating to sureties and guarantors would but for this provision have the effect of releasing the Bank from its liability and obligation under this Guarantee and the Bank hereby waives all of its rights under any such law.
6. This Guarantee is in addition to and not in substitution of any other guarantee or security now or which may hereafter be held by the Authority in respect of or relating to the Agreement or for the fulfillment, compliance and/or performance of all or any of the obligations of the Contractor under the Agreement.
7. Notwithstanding anything contained hereinbefore, the liability of the Bank under this Guarantee is restricted to the Guarantee Amount and this Guarantee will remain in force for the period specified in paragraph 8 below and unless a demand or claim in writing is made by the Authority on the Bank under this Guarantee all rights of the Authority under this Guarantee shall be forfeited and the Bank shall be relieved from its liabilities hereunder.
8. The Guarantee shall cease to be in force and effect on ****¹. Unless a demand or claim under this Guarantee is made in writing before expiry of the Guarantee, the Bank shall be discharged from its liabilities hereunder.
9. The Bank undertakes not to revoke this Guarantee during its currency, except with the previous express consent of the Authority in writing, and declares and warrants that it has the power to issue this Guarantee and the undersigned has full powers to do so on behalf of the Bank.
10. Any notice by way of request, demand or otherwise hereunder may be sent by post addressed to the Bank at its above referred branch, which shall be deemed to

¹ Insert date being 2 (two) years from the date of issuance of this Guarantee (in accordance with Clause 7.2 of the Agreement).

have been duly authorised to receive such notice and to effect payment thereof forthwith, and if sent by post it shall be deemed to have been given at the time when it ought to have been delivered in due course of post and in proving such notice, when given by post, it shall be sufficient to prove that the envelope containing the notice was posted and a certificate signed by an officer of the Authority that the envelope was so posted shall be conclusive.

11. This Guarantee shall come into force with immediate effect and shall remain in force and effect for up to the date specified in paragraph 8 above or until it is released earlier by the Authority pursuant to the provisions of the Agreement.

Signed and sealed this _____ day of, 20_____ at _____

SIGNED, SEALED AND DELIVERED

For and on behalf of the Bank by:
(Signature)

(Name)

(Designation)

(Code Number)

(Address)

NOTES:

- (i) The bank guarantee should contain the name, designation and code number of the officer(s) signing the guarantee.
- (ii) The address, telephone number and other details of the head office of the Bank as well as of issuing branch should be mentioned on the covering letter of issuing branch.

Annex - II
(Schedule - G)
(See Clause 19.2)

Annex – II: Form for Guarantee for Advance Payment

[DG (RD) &SS,

Ministry of Road Transport & Highways Transport Bhawan, New Delhi]

WHEREAS:

- (A) [name and address of contractor] (hereinafter called the "**Contractor**") has executed an agreement (hereinafter called the "**Agreement**") with the [name and address of the authority], (hereinafter called the "**Authority**") for the Construction and upgradation of existing road to 2-lane with Paved shoulder from km. 20.340 (Rongli Bazzar) to km. 26.588 (Rongli Bypass End) and upgradation of existing road at km 20.600 & km 26.400 for length of 0.520 km & 0.554 km of Rhenok – Menla spur (NH-717B) Package-II A in the State of Sikkim on Engineering, Procurement and Construction (the "**EPC**") basis, subject to and in accordance with the provisions of the Agreement
- (B) In accordance with Clause 19.2 of the Agreement, the Authority shall make to the Contractor an interest bearing @Bank Rate + 3% advance payment (herein after called "**Advance Payment**") equal to 10% (ten per cent) of the Contract Price; and that the Advance Payment shall be made in two installments subject to the Contractor furnishing an irrevocable and unconditional guarantee by a scheduled bank for an amount equivalent to 110% (one hundred and ten percent) of such installment to remain effective till the complete and full repayment of the installment of the Advance Payment as security for compliance with its obligations in accordance with the Agreement. The amount of {first/second} installment of the Advance Payment is Rs. _____ cr. (Rupees _____ crore) and the amount of this Guarantee is Rs. _____ cr. (Rupees _____ crore) (the "**Guarantee Amount**")².
- (C) We, through our branch at (the "Bank") have agreed to furnish this bank guarantee (hereinafter called the "Guarantee") for the Guarantee Amount.

NOW, THEREFORE, the Bank hereby, unconditionally and irrevocably, guarantees and affirms as follows:

1. The Bank hereby unconditionally and irrevocably guarantees the due and faithful repayment on time of the aforesaid instalment of the Advance Payment under and in accordance with the Agreement, and agrees and undertakes to pay to the Authority, upon its mere first written demand, and without any demur, reservation, recourse, contest or protest, and without any reference to the Contractor, such sum or sums up to an aggregate sum of the Guarantee Amount as the Authority shall claim, without the Authority being required to prove or to show grounds or reasons for its demand and/or for the sum specified therein.

A letter from the Authority, under the hand of an officer not below the rank of [General Manager in the National Highways Authority of India], that the Contractor has committed default in the due and faithful performance of all or any of its obligations for the repayment of the instalment of the Advance Payment under and in accordance with the Agreement shall be conclusive, final and binding on the Bank. The Bank further agrees that the Authority shall be the sole judge as to whether the Contractor is in default in due and faithful performance of its obligations during and under the Agreement and its decision that the Contractor is in default shall be final and binding on the Bank, notwithstanding any differences between the Authority and the Contractor, or any dispute between them pending before any court, tribunal, arbitrators or any other authority or body, or by the discharge of the Contractor for any reason whatsoever

² The Guarantee Amount should be equivalent to 110% of the value of the applicable instalment

2. In order to give effect to this Guarantee, the Authority shall be entitled to act as if the Bank were the principal debtor and any change in the constitution of the Contractor and/or the Bank, whether by their absorption with any other body or corporation or otherwise, shall not in any way or manner affect the liability or obligation of the Bank under this Guarantee.
3. It shall not be necessary, and the Bank hereby waives any necessity, for the Authority to proceed against the Contractor before presenting to the Bank its demand under this Guarantee.
4. The Authority shall have the liberty, without affecting in any manner the liability of the Bank under this Guarantee, to vary at any time, the terms and conditions of the Advance Payment or to extend the time or period of its repayment or to postpone for any time, and from time to time, any of the rights and powers exercisable by the Authority against the Contractor, and either to enforce or forbear from enforcing any of the terms and conditions contained in the Agreement and/or the securities available to the Authority, and the Bank shall not be released from its liability and obligation under these presents by any exercise by the Authority of the liberty with reference to the matters aforesaid or by reason of time being given to the Contractor or any other forbearance, indulgence, act or omission on the part of the Authority or of any other matter or thing whatsoever which under any law relating to sureties and guarantors would but for this provision have the effect of releasing the Bank from its liability and obligation under this Guarantee and the Bank hereby waives all of its rights under any such law.
5. This Guarantee is in addition to and not in substitution of any other guarantee or security now or which may hereafter be held by the Authority in respect of or relating to the Advance Payment.
6. Notwithstanding anything contained hereinbefore, the liability of the Bank under this Guarantee is restricted to the Guarantee Amount and this Guarantee will remain in force for the period specified in paragraph 8 below and unless a demand or claim in writing is made by the Authority on the Bank under this Guarantee all rights of the Authority under this Guarantee shall be forfeited and the Bank shall be relieved from its liabilities hereunder.
7. The Guarantee shall cease to be in force and effect on ****³ Unless a demand or claim under this Guarantee is made in writing on or before the aforesaid date, the Bank shall be discharged from its liabilities hereunder.
8. The Bank undertakes not to revoke this Guarantee during its currency, except with the previous express consent of the Authority in writing, and declares and warrants that it has the power to issue this Guarantee and the undersigned has full powers to do so on behalf of the Bank.
9. Any notice by way of request, demand or otherwise hereunder may be sent by post addressed to the Bank at its above referred branch, which shall be deemed to have been duly authorised to receive such notice and to effect payment thereof forthwith, and if sent by post it shall be deemed to have been given at the time when it ought to have been delivered in due course of post and in proving such notice, when given by post, it shall be sufficient to prove that the envelope containing the notice was posted and a certificate signed by an officer of the Authority that the envelope was so posted shall be conclusive.

³ Insert a date being 90 (ninety) days after the end of one year from the date of payment of the Advance payment to the Contractor (in accordance with Clause 19.2 of the Agreement).

10. This Guarantee shall come into force with immediate effect and shall remain in force and effect up to the date specified in paragraph 8 above or until it is released earlier by the Authority pursuant to the provisions of the Agreement.

Signed and sealed this day of....., 20..... at
SIGNED, SEALED AND DELIVERED

For and on behalf of the Bank by:

(Signature)

(Name)

(Designation)

(Code Number)

(Address)

NOTES:

- (i) The bank guarantee should contain the name, designation and code number of the officer(s) signing the guarantee.

The address, telephone number and other details of the head office of the Bank as well as of issuing branch should be mentioned on the covering letter of issuing branch

Schedule-H

(See Clause 10.1 (iv) and 19.3)

Contract Price Weightages

1.1 The Contract Price for this Agreement is Rs -----

1.2 Proportions of the Contract Price for different stages of Construction of the Project Highway shall be as specified below:

Item	Weightage in percentage to the Contract Price	Stage for Payment	Percentage weightage
1	2	3	4
Road works including culverts, widening and repair of culverts.	15.149 %	A- Widening and strengthening of existing road	
		(1) Earthwork up to top of the sub-grade	7.886%
		(2) Sub-base Course/CTSB	1.843%
		(3) Non Bituminous Base Course	0.00%
		(4) Bituminous Base Course/BSM	2.065%
		(5) Wearing Coat/BC	1.226%
		(6) Widening and repair of culvert	0.00%
		B1- Reconstruction/ New 2-Lane realignment/bypass (Flexible Pavement)	
		(1) Earthwork up to top of the sub-grade	48.445%
		(2) Cement Treated Sub Base (CTSB)	11.322%
		(3) Bituminous Stabilized Material (BSM)	12.678%
		(4) BC	7.533%
		B2- Reconstruction/ New 2-Lane realignment/bypass (Rigid Pavement)	
		(1) Earthwork up to top of the sub-grade	0.000%
		(2) Sub-base Course	0.000%
		(3) Dry Lean Concrete (DLC) Course	0.000%
		(4) Pavement Quality Control (PQC) Course	0.000%
		C1- Reconstruction/ New Service Road (Flexible Pavement)	
		(1) Earthwork up to top of the sub-grade	0.00%
		(2) Sub-base Course	0.00%
(3) Non Bituminous Base Course	0.00%		
(4) Bituminous Base Course	0.00%		
(5) Wearing Coat	0.00%		

Construction and upgradation of existing road to 2-lane with Paved shoulder from km. 20.340 (Rongli Bazaar) to km. 26.588 (Rongli Bypass End) and upgradation of existing road at km 20.600 & km 26.400 for length of 0.520 km & 0.554 km of Rhenok – Menla spur (NH-717B) Package-II A on EPC Basis under SARDP-NE Phase ‘A’ in the State of Sikkim.

Item	Weightage in percentage to the Contract Price	Stage for Payment	Percentage weightage
		C2- Reconstruction/ New Service Road (Rigid Pavement)	
		(1) Earthwork up to top of the sub-grade	0.00%
		(2) Sub-base Course	0.00%
		(3) Dry Lean Concrete (DLC) Course	0.00%
		(4) Pavement Quality Control (PQC) Course	0.00%
		D - Re-Construction and new culverts on existing road, realignments on existing road, realignments, bypasses:	
		Culverts(Length<6m)	7.002%
Minor Bridges/Underpasses/ Overpasses	0.00%	<u>A1-Widening and Repairs of Minor Bridges (Length>6m and <60m)</u>	
		Minor bridges	0.00%
		<u>A2-New Minor Bridges (Length>6m and <60m)</u>	
		(1) Foundation	
		On completion of the foundation work including foundations for wing and return walls, abutments, piers.	0.00%
		(2) Sub-structure:	
		On completion of abutments, piers upto the abutment/ pier cap including wing/ return/ retaining wall upto top	0.00%
		(3) Super Structure:	
		On completion of the super-structure in all respects including Girder, Deck slab, bearings	0.00%
		(4) Approaches:	
		On completion of approaches including Retaining walls, stone pitching, protection works complete in all respect and fit for use	0.00%
		(5) Guide Bund and River Training Works:	
		On completion of Guide Bund and River Training Works complete in all respect.	0.00%
		(6) Other Ancilliary Works:	

Construction and upgradation of existing road to 2-lane with Paved shoulder from km. 20.340 (Rongli Bazaar) to km. 26.588 (Rongli Bypass End) and upgradation of existing road at km 20.600 & km 26.400 for length of 0.520 km & 0.554 km of Rhenok – Menla spur (NH-717B) Package-II A on EPC Basis under SARDP-NE Phase ‘A’ in the State of Sikkim.

Item	Weightage in percentage to the Contract Price	Stage for Payment	Percentage weightage
		On completion of wearing coat, expansion joints, hand rails, crash barriers, road signs & markings, tests on completion in all respect.	0.00%
		B.1- Widening and repair of Underpasses/overpasses	
		Underpasses/Overpasses	0.00%
		B.2- New Underpasses/overpasses	
		(1) Foundation	
		On completion of the foundation work including foundations for wing and return walls, abutments, piers.	0.00%
		(2) Sub-structure	
		On completion of abutments, piers upto the abutment/ pier cap including wing/ return/ retaining wall upto top	0.00%
		(3) Super Structure:	
		On completion of the super-structure in all respects including Girder, Deck slab, bearings	0.00%
		Wearing Coat (a) in case of Overpass-wearing coat including expansion joint complete in all respect as specified and (b) in case of underpass rigid pavement including drainage facility complete in all respects as specified.	
		(4) On completion of Retaining / Reinforced earth walls, complete in all respect and fit for use	0.00%
		(5) Approaches and other Ancillary Works:	
On completion of wearing coat, expansion joints, hand rails, crash barriers, stone pitching, protection works, road signs & markings, tests on completion in all respect. Wearing Coat (a) in case of Overpass wearing coat including expansion joints complete in all respect as specified and (b) in case of underpass-rigid pavement including drainage facility complete in all respects as specified	0.00%		
Major Bridge (length>60m) works and	69.228%	<u>A.1 -Widening and repairs of Major Bridges</u>	

Construction and upgradation of existing road to 2-lane with Paved shoulder from km. 20.340 (Rongli Bazaar) to km. 26.588 (Rongli Bypass End) and upgradation of existing road at km 20.600 & km 26.400 for length of 0.520 km & 0.554 km of Rhenok – Menla spur (NH-717B) Package-II A on EPC Basis under SARDP-NE Phase ‘A’ in the State of Sikkim.

Item	Weightage in percentage to the Contract Price	Stage for Payment	Percentage weightage		
RUB/ROB/elevated sections/flyovers including viaducts, if any		(1) Foundation: on completion of the foundation work including foundations for return walls, abutments, piers	0.00%		
		(2) Sub-structure: on completion abutments, piers upto the abutment/Pier cap	0.00%		
		(3) Super-structure: On completion of the super-structure in all respects including girder, deck slab, bearings	0.00%		
		(4) Wearing coat including expansion joints	0.00%		
		(5) Miscellaneous items like hand rails, crash barriers, road markings etc.	0.00%		
		(6) Wing walls/Return Walls	0.00%		
		(7) Guide bunds, River Training Works etc	0.00%		
		(8) Approaches (including retaining walls, stone pitching and protection works)	0.00%		
		<u>A.2 -New Major Bridges</u>			
		(1) Foundation: on completion of the foundation work including foundations for return walls, abutments, piers	0.00%		
		(2) Sub-structure: on completion abutments, piers upto the abutment/Pier cap	0.00%		
		(3) Super-structure: On completion of the super-structure in all respects including girder,deck slab, bearings	0.00%		
		(4) Wearing Coat including expansion joints	0.00%		
		(5) Miscellaneous items like hand rails, crash barriers, road markings etc.	0.00%		
		(6) Wing walls/Return Walls	0.00%		
		(7) Guide bunds, River Training Works etc	0.00%		
		(8) Approaches (including retaining walls, stone pitching and protection works)	0.00%		
		<u>B.1-Widening and repair of</u>			
		(a) ROB			
		(b) RUB			
		(1) Foundation	0.00%		
		(2) Sub-structure	0.00%		

Construction and upgradation of existing road to 2-lane with Paved shoulder from km. 20.340 (Rongli Bazzar) to km. 26.588 (Rongli Bypass End) and upgradation of existing road at km 20.600 & km 26.400 for length of 0.520 km & 0.554 km of Rhenok – Menla spur (NH-717B) Package-II A on EPC Basis under SARDP-NE Phase ‘A’ in the State of Sikkim.

Item	Weightage in percentage to the Contract Price	Stage for Payment	Percentage weightage	
		(3) Super-structure (including bearings)	0.00%	
		(4) Wearing Coat (a) in case of ROB - wearing coat including expansion joint complete in all respect as specified and (b) in case of RUB rigid pavement under RUB including drainage facility complete in all respects as specified.	0.00%	
		(5) Miscellaneous items like hand rails, crash barriers, road markings etc.	0.00%	
		(6) Wing walls/Return Walls	0.00%	
		(7) Retaining/Reinforced earth walls	0.00%	
		(8) Approaches and ancillary works (wearing coat, expansion joints, hand rails, crash barriers, road signs & markings, stone pitching, protection works etc.))	0.00%	
		<u>B.2-New ROB/RUB</u>		
		(a) ROB		
		(b) RUB		
		(1) Foundation	0.00%	
	(2) Sub-structure	0.00%		
	(3) Super-structure (including bearings)	0.00%		
			(4) Wearing Coat (a) in case of ROB - wearing coat including expansion joint complete in all respect as specified and (b) in case of RUB rigid pavement under RUB including drainage facility complete in all respects as specified.	0.00%
			(5) Miscellaneous items like hand rails, crash barriers, road markings etc.	0.00%
			(6) Wing walls/Return Walls	0.00%
			(7) Retaining/Reinforced earth walls	0.00%
			(8) Approaches and ancillary works (wearing coat, expansion joints, hand rails, crash barriers, road signs & markings, stone pitching, protection works etc.))	0.00%
			C.1- Widening and repair of Elevated Sections/Flyovers/Grade Separators	
			(1) Foundation	0.00%
			(2) Sub-structure	0.00%
(3) Super-structure (including bearings)			0.00%	

Construction and upgradation of existing road to 2-lane with Paved shoulder from km. 20.340 (Rongli Bazaar) to km. 26.588 (Rongli Bypass End) and upgradation of existing road at km 20.600 & km 26.400 for length of 0.520 km & 0.554 km of Rhenok – Menla spur (NH-717B) Package-II A on EPC Basis under SARDP-NE Phase ‘A’ in the State of Sikkim.

Item	Weightage in percentage to the Contract Price	Stage for Payment	Percentage weightage
		(4) Wearing Coat including expansion joints.	0.00%
		(5) Miscellaneous items like hand rails, crash barriers, road markings etc.	0.00%
		(6) Wing walls/Return Walls	0.00%
		(7) Retaining/Reinforced earth walls	0.00%
		(8) Approaches and ancillary works (wearing coat, expansion joints, hand rails, crash barriers, road signs & markings, stone pitching, protection works etc.))	0.00%
		C.2.New Elevated Sections / Flyovers / Grade Separators	
		(1) Foundation: On completion of the foundation work including foundations for wing and return walls, abutments, piers.	10.020%
		(2) Sub-structure: On completion of abutments, piers upto the abutment/pier cap including wing/return/retaining wall upto top	41.594%
		(3) Super-structure: On completion of the super structure in all respects including girder, deck slab, bearings	41.082%
		(4) Wearing Coat including expansion joints.	4.382%
		(5) Miscellaneous items like hand rails, crash barriers, road markings etc.	2.922%
		(6) Wing walls/Return Walls	0.00%
		(7) Retaining/Reinforced earth walls	0.00%
		(8) Approaches and ancillary works (wearing coat, expansion joints, hand rails, crash barriers, road signs & markings, stone pitching, protection works etc.))	0.00%
Other works	15.623%	(i) Toll Plaza	0.00%
		(ii)Road side drains	
		Lined Drain/Catch water Drain	4.608%
		Cover Drain	0.000%
		(iii)Road signs, markings, km stones, safety devices, ...	2.636%
		(iv) Road Studs	1.083%

Construction and upgradation of existing road to 2-lane with Paved shoulder from km. 20.340 (Rongli Bazzar) to km. 26.588 (Rongli Bypass End) and upgradation of existing road at km 20.600 & km 26.400 for length of 0.520 km & 0.554 km of Rhenok – Menla spur (NH-717B) Package-II A on EPC Basis under SARDP-NE Phase ‘A’ in the State of Sikkim.

Item	Weightage in percentage to the Contract Price	Stage for Payment	Percentage weightage
		(v)Project facilities	0.00%
		a) Bus Shelter	0.201%
		b) Truck lay bye	0.00%
		c) Rest Areas	0.00%
		d) Others (Includes junction and Site Clearance)	3.643%
		(vi)Retaining Wall	58.305%
		(vii) Breast Wall	14.762%
		(viii)RE Wall	0.00%
		(ix) Street Lighting	0.00%
		(x) Utility ducts	0.00%
		(xi) Parapet wall	1.710%
		(xii) Footpath and separators	0.00%
		(xiii) Hydroseeding by mechanical means	12.515%
		(xiv)Road side plantation including horticulture in wayside amenities	0.00%
		(xv) Slope Stabilization work by terra lock pins, terra lock anchors and turf reinforced mat	0.00%
		(xvi)Safety and traffic management during construction	0.537%
		(xvii)Protection works like pitching on side slopes, chutes, crash barrier	0.00%

1.3 Procedure of estimating the value of work done.

1.3.1 Road works

Procedure for estimating the value of road work done shall be as follows:

Table 1.3.1

Stage of Payment	Percentage - weightage	Payment Procedure
A- Widening and strengthening of existing road		Unit of measurement is linear length. Payment of each stage shall be made on pro rata basis on completion of a stage in a length of not less than 10 (ten) percent of the total length.
(1) Earthwork up to top of the sub-grade	7.886%	
(2) Sub-base Course/CTSB	1.843%	
(3) Non Bituminous Base Course	0.000%	
(4) Bituminous Base Course/BSM	2.065%	
(5) Wearing Coat/BC	1.226%	

Construction and upgradation of existing road to 2-lane with Paved shoulder from km. 20.340 (Rongli Bazaar) to km. 26.588 (Rongli Bypass End) and upgradation of existing road at km 20.600 & km 26.400 for length of 0.520 km & 0.554 km of Rhenok – Menla spur (NH-717B) Package-II A on EPC Basis under SARDP-NE Phase 'A' in the State of Sikkim.

Stage of Payment	Percentage - weightage	Payment Procedure
(6) Widening and repair of culvert	0.00%	Cost of completed culverts shall be determined pro rate with respect to the total number of culverts. Payment shall be made on the completion of atleast five culverts.
B1- Reconstruction / New 2-Lane realignment / bypass (Flexible Pavement)		Unit of measurement is linear length. Payment of each stage shall be made on pro rata basis on completion of a stage in full length or 5 (five) km length whichever is less.
(1) Earthwork up to top of the sub-grade	48.445%	
(2) Cement Treated Sub Base (CTSB)	11.322%	
(3) Bituminous Stabilized Material (BSM)	12.678%	
(4) BC	7.533%	
B2- Reconstruction/ New 2-Lane realignment/bypass (Rigid Pavement)		Unit of measurement is linear length. Payment of each stage shall be made on pro rata basis on completion of a stage in full length or 5 (five) km length whichever is less.
(1) Earthwork up to top of the sub-grade	0.000%	
(2) Sub-base Course	0.000%	
(3) Dry Lean Concrete (DLC) Course	0.000%	
(4) Pavement Quality Control (PQC) Course	0.000%	
C1- Reconstruction/ New Service Road (Flexible Pavement)		Unit of measurement is linear length. Payment of each stage shall be made on pro rata basis on completion of a stage in full length or 5 (five) km length whichever is less.
(1) Earthwork up to top of the sub-grade	0.00%	
(2) Sub-base Course	0.00%	
(3) Non Bituminous Base Course	0.00%	
(4) Bituminous Base Course	0.00%	
(5) Wearing Coat	0.00%	
C2- Reconstruction/ New Service Road (Rigid Pavement)		Unit of measurement is linear length. Payment of each stage shall be made on pro rata basis on completion of a stage in full length or 5 (five) km length whichever is less.
(1) Earthwork up to top of the sub-grade	0.00%	
(2) Sub-base Course	0.00%	
(3) Dry Lean Concrete (DLC) Course	0.00%	
(4) Pavement Quality Control (PQC) Course	0.00%	
D - Re-Construction and new culverts on existing road, realignments on existing road, realignments, bypasses:		Cost of completed culverts shall be determined pro rate with respect to the total number of culverts. Payment shall be made on the completion of atleast five culverts.
Culverts (Length < 6m)	7.002%	

@ For calculation of payment stage for main-carriageway the project length shall be converted into equivalent 2 lane length. For example, if the total length of 4 lane main carriageway is 100 km, then the equivalent length for calculation of payment stage will be 2 x 100 km. Now, if the

total length of bituminous work to be done is 100 km, the cost per km of bituminous work shall be determined as follows:

Cost per km = P x weightage for road work x weightage for bituminous work x (1/L)

Where

P = Contract Price

L = Total equivalent 2-Lane length in km as defined above

Similarly, the rates per km for other stages shall be worked out accordingly

Note: The length affected due to law and order problems or litigation during execution including the length not handed over to the Contractor under clause 8.3 of this Contract Agreement due to which the Contractor is unable to execute the work, may be deducted from the total project length for payment purposes. The total length calculated here is only for payment purposes and will not affect and referred in other clauses of the Contract Agreement.

1.3.2 Minor Bridge and Underpasses/Overpasses

Procedure for estimating the value of Minor Bridge works and Underpasses/Overpasses shall be stated in table 1.3.2

Table 1.3.2

Stage of Payment	Percentage - weightage	Payment Procedure
1	2	3
<u>A1-Widening and Repairs of Minor Bridges (Length>6m and <60m)</u>	0.0%	Cost of each minor bridge shall be determined on pro rata basis with respect to the total linear length of the minor bridges. Payment shall be made on the completion of widening and repair works of a minor bridge.
<u>A2-New Minor Bridges</u>		
(i) Foundation:		(i) Foundation: Cost of each minor bridge shall be determined on pro rata basis with respect to the total linear length (m) of the minor bridges. Payment against foundation+sub structure shall be made on pro rata basis on completion of a stage i.e. not less than 25% of the scope of foundation each bridge.
On completion of the foundation work including foundations for wing and return walls, abutments, piers.	0.0%	In case where load testing is required for foundation, the trigger of first payment shall include load testing also where specified
(ii) Sub-structure:		
On completion of abutments, piers upto the abutment/pier cap including wing/return/retaining wall upto top	0.0%	Sub-structure: Cost of each minor bridge shall be determined on pro- rata basis with respect to the total linear length (m) of the minor bridges. Payment against sub- structure shall be made on pro-rata basis on completion of a stage i.e. not less than 25% of the scope of sub-structure of each bridge.
(iii) Super Structure:		(ii) Super Structure:

Stage of Payment	Percentage - weightage	Payment Procedure
On completion of the super structure in all respects including girder,deck slab,bearings	0.0%	Super-structure: Payment shall be made on pro-rata basis on completion of a stage i.e. completion of super structure of atleast one span in all respects as specified in the column of "Stage of Payment" in this sub- clause. In case of structures where pre-cast girders have been proposed by the Contractor, 50% of the stage payment shall be due and payable on casting of girders for each span and balance 50% of the stage payment shall be made on completion of stage specified as above
(iv) Approaches:		(iii) Approaches:
On completion of approaches including Retaining walls, stone pitching, protection works complete in all respect and fit for use	0.0%	Payment shall be made on pro rata basis on completion of a stage i.e. completion of approaches in all respect as specified in the column of " Stage of Payment" in this sub clause.
(v) Guide Bund and River Training Works:		(iv) Guide Bund and River Training Works:
On completion of Guide Bund and River Training Works complete in all respect.	0.00%	Payment shall be made on pro rata basis on completion of a stage i.e. completion of Guide Bunds and River Training Works in all respect as specified.
(6) Other Ancillary Works: On Completion of wearing coat,expansion joints, hand rails, crash barriers, road signs markings, tests on completion in all respect.	0.0%	Other Ancillary Works: Payment shall be made on pro-rata basis on completion of a stage in all respects as specified
B.1- Widening and repair of Underpasses/overpasses		Cost of each overpass/underpass shall be determined on pro rata basis with respect to the total linear length of the underpass/overpass. Payment shall be made on the completion of wiening & repair works of a underpass/overpass.
B.2- New Underpasses/overpasses		
(i) Foundation:		(i) Foundation: Cost of each minor bridge shall be determined on pro rata basis with respect to the total linear length (m) of the minor bridges. Payment against foundation+sub structure shall be made on pro rata basis on copletion of a stage i.e. not less than 25% of the scope of foundation each bridge. In case where load testing is required for foundation, the trigger of first payment shall include load testing also where specified
On completion of the foundation work including foundations for wing and return walls, abutments, piers.	0.00%	
(ii) Sub-structure:		
On completion of abutments, piers upto the abutment/pier cap including wing/return/retaining wall upto top	0.00%	Sub-structure: Cost of each minor bridge shall be determined on pro- rata basis with respect to the total linear length (m) of the minor bridges. Payment against sub- structure shall be made on pro-rata basis on completion of a stage

Stage of Payment	Percentage - weightage	Payment Procedure
		i.e. not less than 25% of the scope of sub-structure of each bridge.
(iii) Super Structure:		(ii) Super Structure:
On completion of the super structure in all respects including girder,deck slab,bearings	0.00%	Super-structure: Payment shall be made on pro-rata basis on completion of a stage i.e. completion of super structure of atleast one span in all respects as specified in the column of "Stage of Payment" in this sub- clause. In case of structures where pre-cast girders have been proposed by the Contractor, 50% of the stage payment shall be due and payable on casting of girders for each span and balance 50% of the stage payment shall be made on completion of stage specified as above
(iv) On completion of Retaining /Reinforced earth walls complete in all respect and fit for use	0.00%	Payments shall be made on pro rata basis on completion of 20% of the Total area.
(iii) Approaches:		(iii) Approaches:
On completion of approaches including Retaining Walls, stone pitching, protection works complete in all respect and fit for use	0.00%	Payment shall be made on pro rata basis on completion of a stage in all respect as specified

1.3.3 Major Bridge Works, ROB/RUB and Structures.

Procedure for estimating the value of Major Bridge Works, ROB/RUB and Structures work shall be as stated in table 1.3.3:

Table 1.3.3

Stage of Payment	Percentage - weightage	Payment Procedure
1	2	3
A1-Widening and Repairs of Major Bridges		
(i) Foundation:		(i) Foundation: Cost of each Major bridge shall be determined on pro rata basis with respect to the total linear length (m) of the Major bridges. Payment against foundation shall be made on pro rata basis on completion of a stage i.e. not less than 25% of the scope of foundation of Major Bridge subject to completion of atleast two foundations of the Major Bridge. In case where load testing is required for foundation, the trigger of first payment shall include load testing also where specified.
On completion of the foundation work including foundations for wing and return walls ,abutments,piers upto the abutment/pier cap	0.00%	
(ii) Sub Structure:		(ii) Sub Structure:
On completion of abutments, piers upto the abutment/pier cap including wing/ return/retaining wall upto top	0.00%	Payment against sub structure shall be made on pro rata basis on completion of a stage i.e. not less than 25% of the scope of sub structure of Major Bridge subject to completion of atleast two sub structure of the abutment/pier upto abutment/pier cap level of the major bridge.
(iii) Super Structure		(iii) Super Structure:
On completion of the super structure in all respect including wearing coat, bearings, expansion joints, hand rails, crash barriers,road sign & markings, tests on completion etc. complete in all respect,	0.00%	Payment shall be made on pro rata basis on completion of a stage i.e. completion of super structure including bearings of atleast one span in all respect as specified.
(iv) Wearing Coat including expansion joints.		Wearing Coat
	0.00%	Payment shall be made on completion of wearing coat including expansion joints complete in all respect as specified.
(v) Miscellaneous items like hand rails, crash barriers, road markings etc.		(v) Miscellaneous
	0.00%	Payment shall be made on completion of all Miscellaneous works like hand rails, crash barriers, road markings etc.complete in all respect as specified.
(vi) Wing walls/Return Walls		(vi) Wing walls/Return Walls

Construction and upgradation of existing road to 2-lane with Paved shoulder from km. 20.340 (Rongli Bazzar) to km. 26.588 (Rongli Bypass End) and upgradation of existing road at km 20.600 & km 26.400 for length of 0.520 km & 0.554 km of Rhenok – Menla spur (NH-717B) Package-II A on EPC Basis under SARDP-NE Phase ‘A’ in the State of Sikkim.

Stage of Payment	Percentage - weightage	Payment Procedure
	0.00%	Payment shall be made on completion of all Wing walls/Return Walls complete in all respect as specified.
(vii) Guide bunds, River Training Works etc		(vii) Guide bunds, River Training Works etc
	0.00%	Payment shall be made on completion of all Guide bunds/River Training Works etc. complete in all respect as specified.
(viii) Approaches (including retaining walls, stone pitching and protection works)		(viii) Approaches:
	0.00%	Payment shall be made on completion of both approaches including stone pitching, protection works, etc. complete in all respects as specified.
A2-New Major Bridges		
(i) Foundation:		(i) Foundation: Cost of each Major bridge shall be determined on pro rata basis with respect to the total linear length (m) of the Major bridges. Payment against foundation shall be made on pro rata basis on completion of a stage i.e. not less than 25% of the scope of foundation of Major Bridge subject to completion of atleast two foundations of the Major Bridge. In case where load testing is required for foundation, the trigger of first payment shall include load testing also where specified.
On completion of the foundation work including foundations for wing and return walls ,abutments, piers.	0.00%	
(ii) Sub Structure:		(ii) Sub Structure:
On completion of abutments, piers upto the abutment/pier cap including wing/return/retaining wall upto top	0.00%	Payment against sub structure shall be made on pro rata basis on completion of a stage i.e. not less than 25% of the scope of sub structure of Major Bridge subject to completion of atleast two sub structure of the abutment/pier upto abutment/pier cap level of the major bridge.
(iii) Super Structure		(iii) Super Structure:
On completion of the super structure in all respects including girder,deck slab,bearings	0.00%	Payment shall be made on pro rata basis on completion of a stage i.e. completion of super structure including bearings of atleast one span in all respect as specified.
(iv) Wearing Coat including expansion joints.		Wearing Coat
	0.00%	Payment shall be made on completion of wearing coat including expansion joints complete in all respect as specified.
(v) Miscellaneous items like hand rails, crash barriers, road markings etc.		(v) Miscellaneous
	0.00%	Payment shall be made on completion of all Miscellaneous works like hand rails, crash

Stage of Payment	Percentage - weightage	Payment Procedure
		barriers, road markings etc. complete in all respect as specified.
(vi) Wing walls/Return Walls		(vi) Wing walls/Return Walls
	0.00%	Payment shall be made on completion of all Wing walls/Return Walls complete in all respect as specified.
(vii) Guide bunds, River Training Works etc		(vii) Guide bunds, River Training Works etc
	0.00%	Payment shall be made on completion of all Guide bunds/River Training Works etc. complete in all respect as specified.
(viii) Approaches (including retaining walls, stone pitching and protection works)		(viii) Approaches:
	0.00%	Payment shall be made on completion of both approaches including stone pitching, protection works, etc. complete in all respects as specified.
B1 - Widening and repairs of		
(a) ROB		
(b) RUB		
(i) Foundation:	0.00%	(i) Foundation: Cost of each ROB/RUB shall be determined on pro rata basis with respect to the total linear length (m) of the ROB/RUB. Payment against foundation shall be made on pro rata basis on completion of a stage i.e. not less than 25% of the scope of foundation of ROB/RUB subject to completion of atleast two foundations of the ROB/RUB. In case where load testing is required for foundation, the trigger of first payment shall include load testing also where specified.
On completion of the foundation work including foundations for wing and return walls ,abutments,piers upto the abutment/pier cap		
(ii) Sub Structure:		(ii) Sub Structure:
On completion of abutments, piers upto the abutment/pier cap including wing/ return/retaining wall upto top	0.00%	Payment against sub structure shall be made on pro rata basis on completion of a stage i.e. not less than 25% of the scope of sub structure of ROB/RUB subject to completion of atleast two sub structure of the abutment/pier upto abutment/pier cap level of the ROB/RUB.
(iii) Super Structure		(iii) Super Structure:
On completion of the super structure in all respect including wearing coat, bearings, expansion joints, hand rails, crash barriers,road sign & markings, tests on completion etc. complete in all respect,	0.00%	Payment shall be made on pro rata basis on completion of a stage i.e. completion of super structure including bearings of atleast one span in all respect as specified.

Stage of Payment	Percentage - weightage	Payment Procedure
(iv) Wearing Coat including expansion joints in case of ROB. In case of RUB, rigid pavement under RUB including drainage facility as specified.		(iv) Wearing Coat:
	0.00%	Payment shall be made on completion of (a) in case of ROB - wearing coat including expansion joint complete in all respect as specified and (b) in case of RUB rigid pavement under RUB including drainage facility complete in all respects as specified.
(v) Miscellaneous items like hand rails, crash barriers, road markings etc.		(v) Miscellaneous
	0.00%	Payment shall be made on completion of all Miscellaneous works like hand rails, crash barriers, road markings etc. complete in all respect as specified.
(vi) Wing walls/Return Walls		(vi) Wing walls/Return Walls
	0.00%	Payment shall be made on completion of all Wing walls/Return Walls complete in all respect as specified.
(vii) Approaches (including retaining walls, stone pitching and protection works)		(viii) Approaches:
	0.00%	Payment shall be made on completion of both approaches including stone pitching, protection works, etc. complete in all respects as specified.
B2 - New		
(a) ROB		
(b) RUB		
(i) Foundation:		(i) Foundation: Cost of each ROB/RUB shall be determined on pro rata basis with respect to the total linear length (m) of the ROB/RUB. Payment against foundation shall be made on pro rata basis on completion of a stage i.e. not less than 25% of the scope of foundation of ROB/RUB subject to completion of atleast two foundations of the ROB/RUB. In case where load testing is required for foundation, the trigger of first payment shall include load testing also where specified.
On completion of the foundation work including foundations for wing and return walls ,abutments, piers.	0.00%	
(ii) Sub Structure:		(ii) Sub Structure:
On completion of abutments, piers upto the abutment/pier cap including wing/return/retaining wall upto top	0.00%	Payment against sub structure shall be made on pro rata basis on completion of a stage i.e. not less than 25% of the scope of sub structure of ROB/RUB subject to completion of atleast two sub structure of the abutment/pier upto

Construction and upgradation of existing road to 2-lane with Paved shoulder from km. 20.340 (Rongli Bazaar) to km. 26.588 (Rongli Bypass End) and upgradation of existing road at km 20.600 & km 26.400 for length of 0.520 km & 0.554 km of Rhenok – Menla spur (NH-717B) Package-II A on EPC Basis under SARDP-NE Phase ‘A’ in the State of Sikkim.

Stage of Payment	Percentage - weightage	Payment Procedure
		abutment/pier cap level of the ROB/RUB.
(iii) Super Structure		(iii) Super Structure:
On completion of the super structure in all respects including girder,deck slab,bearings	0.00%	Payment shall be made on pro rata basis on completion of a stage i.e. completion of super structure including bearings of atleast one span in all respect as specified.
(iv) Wearing Coat including expansion joints in case of ROB. In case of RUB, rigid pavement under RUB including drainage facility as specified.		(iv) Wearing Coat:
	0.00%	Payment shall be made on completion of (a) in case of ROB - wearing coat including expansion joint complete in all respect as specified and (b) in case of RUB rigid pavement under RUB including drainage facility complete in all respects as specified.
(v) Miscellaneous items like hand rails, crash barriers, road markings etc.		(v) Miscellaneous
	0.00%	Payment shall be made on completion of all Miscellaneous works like hand rails, crash barriers, road markings etc. complete in all respect as specified.
(vi) Wing walls/Return Walls		(vi) Wing walls/Return Walls
	0.00%	Payment shall be made on completion of all Wing walls/Return Walls complete in all respect as specified.
(vii) Approaches (including retaining walls, stone pitching and protection works)		(viii) Approaches:
	0.00%	Payment shall be made on completion of both approaches including stone pitching, protection works, etc. complete in all respects as specified.
C1 - Widening and repairs of Elevated Section/Flyovers/ Grade Separators		
(i) Foundation:	0.00%	(i) Foundation: Cost of each Structure shall be determined on pro rata basis with respect to the total linear length (m) of the structures. Payment against foundation shall be made on pro rata basis on completion of a stage i.e. not less than 25% of the scope of foundation of structures subject to completion of atleast two foundations of the structures.
On completion of the foundation work including foundations for wing and return walls ,abutments,piers upto the abutment/pier cap		In case where load testing is required for foundation, the trigger of first payment shall include load testing also where specified.

Stage of Payment	Percentage - weightage	Payment Procedure
(ii) Sub Structure:		(ii) Sub Structure:
On completion of abutments, piers upto the abutment/pier cap including wing/ return/retaining wall upto top	0.00%	Payment against sub structure shall be made on pro rata basis on completion of a stage i.e. not less than 25% of the scope of sub structure of structures subject to completion of atleast two sub structure of the abutment/pier upto abutment/pier cap level of the structures.
(iii) Super Structure		(iii) Super Structure:
On completion of the super structure in all respect including wearing coat, bearings, expansion joints, hand rails, crash barriers, road sign & markings, tests on completion etc. complete in all respect.	0.00%	Payment shall be made on pro rata basis on completion of a stage i.e. completion of super structure including bearings of atleast one span in all respect as specified.
(iv) Wearing Coat including expansion joints.		Wearing Coat
	0.00%	Payment shall be made on completion of wearing coat including expansion joints complete in all respect as specified.
(v) Miscellaneous items like hand rails, crash barriers, road markings etc.		(v) Miscellaneous
	0.00%	Payment shall be made on completion of all Miscellaneous works like hand rails, crash barriers, road markings etc. complete in all respect as specified.
(vi) Wing walls/Return Walls		(vi) Wing walls/Return Walls
	0.00%	Payment shall be made on completion of all Wing walls/Return Walls complete in all respect as specified.
(vii) Approaches (including retaining walls, stone pitching and protection works)		(viii) Approaches:
	0.00%	Payment shall be made on completion of both approaches including stone pitching, protection works, etc. complete in all respects as specified.
C2-New Elevated Section/ Flyovers/ Grade Separators		
(i) Foundation:		(i) Foundation: Cost of each Structure shall be determined on pro rata basis with respect to the total linear length (m) of the structures. Payment against foundation shall be made on pro rata basis on completion of a stage i.e. not less than 25% of the scope of foundation of structures subject to completion of atleast two foundations of the structures.
On completion of the foundation work including foundations for wing and return walls, abutments, piers.	10.020%	

Construction and upgradation of existing road to 2-lane with Paved shoulder from km. 20.340 (Rongli Bazzar) to km. 26.588 (Rongli Bypass End) and upgradation of existing road at km 20.600 & km 26.400 for length of 0.520 km & 0.554 km of Rhenok – Menla spur (NH-717B) Package-II A on EPC Basis under SARDP-NE Phase ‘A’ in the State of Sikkim.

Stage of Payment	Percentage - weightage	Payment Procedure
		In case where load testing is required for foundation, the trigger of first payment shall include load testing also where specified.
(ii) Sub Structure:		(ii) Sub Structure:
On completion of abutments, piers upto the abutment/pier cap including wing/return/retaining wall upto top	41.594%	Payment against sub structure shall be made on pro rata basis on completion of a stage i.e. not less than 25% of the scope of sub structure of structures subject to completion of atleast two sub structure of the abutment/ pier upto abutment/ pier cap level of the structures.
(iii) Super Structure		(iii) Super Structure:
On completion of the super structure in all respects including girder, deck slab, bearings	41.082%	Payment shall be made on pro rata basis on completion of a stage i.e. completion of super structure including bearings of atleast one span in all respect as specified.
(iv) Wearing Coat including expansion joints.		Wearing Coat
	4.382%	Payment shall be made on completion of wearing coat including expansion joints complete in all respect as specified.
(v) Miscellaneous items like hand rails, crash barriers, road markings etc.		(v) Miscellaneous
	2.922%	Payment shall be made on completion of all Miscellaneous works like hand rails, crash barriers, road markings etc. complete in all respect as specified.
(vi) Wing walls/Return Walls		(vi) Wing walls/Return Walls
	0.00%	Payment shall be made on completion of all Wing walls/Return Walls complete in all respect as specified.
(vii) Approaches (including retaining walls, stone pitching and protection works)		(viii) Approaches:
	0.00%	Payment shall be made on completion of both approaches including stone pitching, protection works, etc. complete in all respects as specified.

1.3.4 Other works.

Procedure for estimating the value of other works done shall be as stated in table 1.3.4:

Table 1.3.4

Stage of Payment	Weightage	Payment Procedure
(i) Toll Plaza	0.00%	Unit of measurement is each completed toll plaza. Payment of each toll plaza shall be made on pro rata basis with respect to the total of all toll plazas.
(ii) Road side drains		Unit of measurement is linear length in km.
Lined Drain/ Catch Water Drain	4.608%	Payment shall be made on pro rata basis on

Stage of Payment	Weightage	Payment Procedure
Cover Drain	0.000%	completion of a stage in a length of not less than 10% (ten per cent) of the total length.
(iii) Road signs, markings, km stones, safety devices, etc.	2.636%	
(iv) Road Studs	1.083%	
(v) Project facilities	0.00%	Payment shall be made on pro rata basis for completed facilities.
a) Bus Shelter	0.201%	
b) Truck Lay Bye	0.00%	
c) Rest Areas	0.00%	
d) Others (Includes junction and Site Clearance)	3.643%	
(vi) Retaining Wall / Breast wall	58.305% 14.762%	Unit of measurement is linear length. Payment shall be made on pro-rata basis on completion of a stage in a length of not less than 10% (ten per cent) of the total length.
(vii) RE Wall	0.00%	Unit of measurement is linear length. Payment shall be made on pro-rata basis on completion of a stage in a length of not less than 10% (ten per cent) of the total length.
(viii) Street Lighting	0.00%	Unit of measurement is linear length. Payment shall be made on pro rata basis on completion of a stage in a length of not less than 10% (ten per cent) of the total length.
(ix) Utility ducts	0.00%	
(x) Parapet wall	1.710%	
(xi) Footpath and separators	0.00%	
(xii) Hydro-seeding by mechanical means	12.515%	
(xiii) Road side plantation	0.00%	
(xiv) Slope Stabilization work by terra lock pins, terra lock anchors and turf reinforced mat	0.00%	
(xv) Safety and traffic management during construction	0.537%	Payment shall be made on prorata basis every six month.
(xvi) Protection works like pitching on side slopes, chutes, crash barrier	0.000%	Unit of measurement is linear length. Payment shall be made on pro rata basis on completion of a stage in a length of not less than 10% (ten per cent) of the total length.

2. Procedure for payment for Maintenance

2.1 The cost for maintenance shall be as stated in Clause 14.1(v).

2.2 Payment for Maintenance shall be made in quarterly installments in accordance with the provisions of Article 14 and Article 19.

Schedule -I

(See Clause 10.2 (iv))

Drawings

1. Drawings

In compliance of the obligations set forth in Clause 10.2 of this Agreement, the Contractor shall furnish to the Authority's Engineer, free of cost, all Drawings listed in Annex-I of this Schedule-I.

2. Additional Drawings

If the Authority's Engineer determines that for discharging its duties and functions under this Agreement, it requires any drawings other than those listed in Annex-I, it may by notice require the Contractor to prepare and furnish such drawings forthwith. Upon receiving a requisition to this effect, the Contractor shall promptly prepare and furnish such drawings to the Authority's Engineer, as if such drawings formed part of Annex-I of this Schedule-I.

Annex -I

(Schedule -I)

Annex –I: List of Drawings

[Note: The Authority shall describe in this Annex-I, all the Drawings that the contractor is required to furnish under Clause 10.2.]

Schedule - J

(See Clause 10.3 (ii))

Project Completion Schedule

1. Project Completion Schedule

During Construction period, the Contractor shall comply with the requirements set forth in this Schedule-J for each of the Project Milestones and the **Scheduled Completion Date**. Within 15 (fifteen) days of the date of each Project Milestone, the Contractor shall notify the Authority of such compliance along with necessary particulars thereof.

2. Project Milestone-I

- (i) Project Milestone-I shall occur on the date falling on the **319th** day from the Appointed Date (the "**Project Milestone-I**").
- (ii) Prior to the occurrence of Project Milestone-I, the Contractor shall have commenced construction of the Project Highway and submitted to the Authority duly and validly prepared Stage Payment Statements for an amount not less than 10% (ten per cent) of the Contract Price.

3. Project Milestone-II

- (i) Project Milestone-II shall occur on the date falling on the **548th** day from the Appointed Date (the "**Project Milestone- II**").
- (ii) Prior to the occurrence of Project Milestone-II, the Contractor shall have continued with construction of the Project Highway and submitted to the Authority duly and validly prepared Stage Payment Statements for an amount not less than 35% (thirty five per cent) of the Contract Price **and should have started construction of all bridges**

4. Project Milestone-III

- (i) Project Milestone-III shall occur on the date falling on the **776th** day from the Appointed Date (the "**Project Milestone- III**").
- (ii) Prior to the occurrence of Project Milestone-III, the Contractor shall have continued with construction of the Project Highway and submitted to the Authority duly and validly prepared Stage Payment Statements for an amount not less than 70% (seventy per cent) of the Contract Price and **should have started construction of all project facilities**.

5. Scheduled Completion Date

- (i) The Scheduled Completion Date shall occur on the **913th** day from the Appointed Date.
- (ii) On or before the Scheduled Completion Date, the Contractor shall have completed construction in accordance with this Agreement.

6. Extension of time

Upon extension of any or all of the aforesaid Project Milestones or the Scheduled Completion Date, as the case may be, under and in accordance with the provisions of this Agreement, the Project Completion Schedule shall be deemed to have been amended accordingly.

Schedule - K

(See Clause 12.1 (ii))

Tests on Completion

1. Schedule for Tests

- (i) The Contractor shall, no later than 30 (thirty) days prior to the likely completion of construction, notify the Authority's Engineer and the Authority of its intent to subject the Project Highway to Tests, and no later than 10 (ten) days prior to the actual date of Tests, furnish to the Authority's Engineer and the Authority detailed inventory and particulars of all works and equipment forming part of Works.
- (ii) The Contractor shall notify the Authority's Engineer of its readiness to subject the Project Highway to Tests at any time after 10 (ten) days from the date of such notice, and upon receipt of such notice, the Authority's Engineer shall, in consultation with the Contractor, determine the date and time for each Test and notify the same to the Authority who may designate its representative to witness the Tests. The Authority's Engineer shall thereupon conduct the Tests itself or cause any of the Tests to be conducted in accordance with Article 12 and this Schedule-K.

2. Tests

- (i) Visual and physical test: The Authority's Engineer shall conduct a visual and physical check of construction to determine that all works and equipment forming part thereof conform to the provisions of this Agreement. The physical tests shall include [***].
- (ii) Riding quality test: Riding quality of each lane of the carriageway shall be checked with the help of a Network Survey Vehicle (NSV) fitted with latest equipments and the maximum permissible roughness for purposes of this Test shall be [2,000 (two thousand)] mm for each kilometre.
- (iii) Tests for bridges: All major and minor bridges shall be subjected to the rebound hammer and ultrasonic pulse velocity tests, to be conducted in accordance with the procedure described in Special Report No. 17: 1996 of the IRC Highway Research Board on Nondestructive Testing Techniques, at two spots in every span, to be chosen at random by the Authority's Engineer. Bridges with a span of 15 (fifteen) metres or more shall also be subjected to load testing.
- (iv) Other tests: The Authority's Engineer may require the Contractor to carry out or cause to be carried additional tests, in accordance with Good Industry Practice, for determining the compliance of the Project Highway with Specifications and Standards, except tests as specified in clause 5, but shall include measuring the reflectivity of road markings and road signs; and measuring the illumination level (lux) of lighting using requisite testing equipment.

- (v) Environmental audit: The Authority's Engineer shall carry out a check to determine conformity of the Project Highway with the environmental requirements set forth in Applicable Laws and Applicable Permits.
- (vi) Safety Audit: The Authority's Engineer shall carry out, or cause to be carried out, a safety audit to determine conformity of the Project Highway with the safety requirements and Good Industry Practice.

3. Agency for conducting Tests

All Tests set forth in this Schedule-K shall be conducted by the Authority's Engineer or such other agency or person as it may specify in consultation with the Authority.

4. Completion Certificate

Upon successful completion of Tests, the Authority's Engineer shall issue the Completion Certificate in accordance with the provisions of Article 12.

5. The Authority Engineer will carry out tests with following equipment at his own cost in the presence of contractor's representative.

Sr. No.	Key metrics of Asset	Equipment to be used	Frequency of condition survey
1	Surface defects of pavement	Network Survey Vehicle (NSV)	At least twice a year (As per survey months defined for the state basis rainy season)
2	Roughness of pavement	Network Survey Vehicle (NSV)	At least twice a year (As per survey months defined for the state basis rainy season)
3	Strength of pavement	Falling Weight Deflectometer (FWD)	At least once a year
4	Bridges	Mobile Bridge Inspection Unit (MBU)	At least twice a year (As per survey months defined for the state basis rainy season)
5	Road signs	Retro-reflectometer	At least twice a year (As per survey months defined for the state basis rainy season)

The first testing with the help of NSV shall be conducted at the time of issue of Completion Certificate.

Schedule - L
(See Clause 12.2)

Completion Certificate

1. I..... (Name of the Authority's Engineer), acting as the Authority's Engineer, under and in accordance with the Agreement dated (the "**Agreement**"), for construction and upgradation of existing road to 2-lane with Paved shoulder from km. 20.340 (Rongli Bazzar) to km. 26.588 (Rongli Bypass End) and upgradation of existing road at km 20.600 & km 26.400 for length of 0.520 km & 0.554 km of Rhenok – Menla spur (NH-717B) Package-IIA on EPC Basis under SARDP-NE Phase 'A' in the State of Sikkim on Engineering, Procurement and Construction (the "**EPC**") basis through..... (Name of Contractor), hereby certify that the Tests in accordance with Article 12 of the Agreement have been successfully undertaken to determine compliance of the Project Highway with the provisions of the Agreement, and I am satisfied that the Project Highway can be safely and reliably placed in service of the Users thereof.

2. It is certified that, in terms of the aforesaid Agreement, all works forming part of Project Highway have been completed, and the Project Highway is hereby declared fit for entry into operation on this the day of20....., Scheduled Completed Date for which was the..... day of..... 20.....

SIGNED, SEALED AND DELIVERED

For and on behalf of the Authority's Engineer by:

(Signature)

(Name)

(Designation) (Address)

Schedule - M
(See Clauses 14.6, 15.2 and 19.7)

Payment Reduction for Non-Compliance

1. Payment reduction for non-compliance with the Maintenance Requirements

- (i) Monthly lump sum payments for maintenance shall be reduced in the case of non-compliance with the Maintenance Requirements set forth in Schedule-E.
- (ii) Any deduction made on account of non-compliance with the Maintenance Requirements shall not be paid even after compliance subsequently. The deductions shall continue to be made every month until compliance is done.
- (iii) The Authority's Engineer shall calculate the amount of payment reduction on the basis of weightage in percentage assigned to non-conforming items as given in Paragraph 2.

2. Percentage reductions in lump sum payments on monthly basis

- (i) The following percentages shall govern the payment reduction:

S.No	Item/Defect/Deficiency	Percentage
(a)	Carriageway/Pavement	
(i)	Potholes, cracks, other surface defects	15%
(ii)	Repairs of Edges, Rutting	5%
(b)	Road, Embankment, Cuttings, Shoulders	
(i)	Edge drop, inadequate cross fall, undulations, settlement, potholes, ponding, obstructions	10%
(ii)	Deficient slopes, raincuts, disturbed pitching, vegetation growth, pruning of trees	5%
(c)	Bridges and Culverts	
(i)	Desilting, cleaning, vegetation growth, damaged pitching, flooring, parapets, wearing course, footpaths, any damage to foundations	20%
(ii)	Any Defects in superstructures, bearings and sub-structures	10%
(iii)	Painting, repairs/replacement kerbs, railings, parapets, guideposts/crash barriers	5%
(d)	Roadside Drains	
(i)	Cleaning and repair of drains	5%
(e)	Road Furniture	
(i)	Cleaning, painting, replacement of road signs, delineators, road markings, 200 m/km/5 th km stones	5%
(f)	Miscellaneous Items	
(i)	Removal of dead animals, broken down/accidented vehicles, fallen trees, road blockades or malfunctioning of mobile crane	10%
(ii)	Any other Defects in accordance with paragraph 1.	5%
(g)	Defects in Other Project Facilities	5%

- (ii) The amount to be deducted from monthly lump-sum payment for non-compliance of particular item shall be calculated as under:

Construction and upgradation of existing road to 2-lane with Paved shoulder from km. 20.340 (Rongli Bazaar) to km. 26.588 (Rongli Bypass End) and upgradation of existing road at km 20.600 & km 26.400 for length of 0.520 km & 0.554 km of Rhenok – Menla spur (NH-717B) Package-II A on EPC Basis under SARDP-NE Phase 'A' in the State of Sikkim.

$$R = \frac{P}{100} \times (M1 \text{ or } M2) \times \frac{L1}{L}$$

Where,

P= Percentage of particular item/Defect/deficiency for deduction

M1= Monthly lump-sum payment in accordance para 1.2 above of this Schedule

M2= Monthly lump-sum payment in accordance para 1.2 above of this Schedule

L1 = Non-complying length L = Total length of the road,

R= Reduction (the amount to be deducted for non-compliance for a particular item/Defect/deficiency)

The total amount of reduction shall be arrived at by summation of reductions for such items/Defects/deficiency or non-compliance.

For any Defect in a part of one kilometer, the non-conforming length shall be taken as one kilometer.

Schedule - N

(See Clause 18.1 (i))

Selection of Authority's Engineer

1. Selection of Authority's Engineer

- (i) The provisions of the Model Request for Proposal for Selection of Technical Consultants, issued by the Ministry of Finance in May 2009, or any substitute thereof shall apply for selection of an experienced firm to discharge the functions and duties of an Authority's Engineer.
- (ii) In the event of termination of the Technical Consultants appointed in accordance with the provisions of Paragraph 1.1, the Authority shall appoint another firm of Technical Consultants forthwith and may engage a government-owned entity in accordance with the provisions of Paragraph 3 of this Schedule-N.

2. Terms of Reference

The Terms of Reference for the Authority's Engineer (the "**TOR**") shall substantially conform with Annex 1 to this Schedule N.

3. Appointment of Government entity as Authority's Engineer

Notwithstanding anything to the contrary contained in this Schedule, the Authority may in its discretion appoint a government-owned entity as the Authority's Engineer; provided that such entity shall be a body corporate having as one of its primary functions the provision of consulting, advisory and supervisory services for engineering projects; provided further that a government-owned entity which is owned or controlled by the Authority shall not be eligible for appointment as Authority's Engineer.

Annex -I
(Schedule - N)

Annex –I: Terms of Reference for Authority's Engineer

1. Scope

- (i) These Terms of Reference (the "**TOR**") for the Authority's Engineer are being specified pursuant to the EPC Agreement dated (the "**Agreement**"), which has been entered into between the [name and address of the Authority] (the "**Authority**") and..... (the "**Contractor**")# for construction and upgradation of existing road to 2-lane with Paved shoulder from km. 20.340 (Rongli Bazzar) to km. 26.588 (Rongli Bypass End) and upgradation of existing road at km 20.600 & km 26.400 for length of 0.520 km & 0.554 km of Rhenok – Menla spur (NH-717B) Package-IIA on Engineering, Procurement and Construction (the "**EPC**") basis, and a copy of which is annexed hereto and marked as Annex-A to form part of this TOR.

- In case the bid of Authority's Engineer is invited simultaneously with the bid of EPC project, then the status of bidding of EPC project only to be indicated

- (ii) The TOR shall apply to construction and maintenance of the Project Highway.

2. Definitions and interpretation

- (i) The words and expressions beginning with or in capital letters and not defined herein but defined in the Agreement shall have, unless repugnant to the context, the meaning respectively assigned to them in the Agreement.
- (ii) References to Articles, Clauses and Schedules in this TOR shall, except where the context otherwise requires, be deemed to be references to the Articles, Clauses and Schedules of the Agreement, and references to Paragraphs shall be deemed to be references to Paragraphs of this TOR.
- (iii) The rules of interpretation stated in Article 1 of the Agreement shall apply, mutatis mutandis, to this TOR.

3. General

- (i) The Authority's Engineer shall discharge its duties in a fair, impartial and efficient manner, consistent with the highest standards of professional integrity and Good Industry Practice.
- (ii) The Authority's Engineer shall perform the duties and exercise the authority in accordance with the provisions of this Agreement, but subject to obtaining prior written approval of the Authority before determining:
- (a) any Time Extension;
 - (b) any additional cost to be paid by the Authority to the Contractor;
 - (c) the Termination Payment; or

Construction and upgradation of existing road to 2-lane with Paved shoulder from km. 20.340 (Rongli Bazzar) to km. 26.588 (Rongli Bypass End) and upgradation of existing road at km 20.600 & km 26.400 for length of 0.520 km & 0.554 km of Rhenok – Menla spur (NH-717B) Package-II A on EPC Basis under SARDP-NE Phase 'A' in the State of Sikkim.

- (d) issuance of Completion Certificate or
 - (e) any other matter which is not specified in (a), (b), (c) or (d) above and which creates a financial liability on either Party.
- (iii) The Authority's Engineer shall submit regular periodic reports, at least once every month, to the Authority in respect of its duties and functions under this Agreement. Such reports shall be submitted by the Authority's Engineer within 10 (ten) days of the beginning of every month.
 - (iv) The Authority's Engineer shall inform the Contractor of any delegation of its duties and responsibilities to its suitably qualified and experienced personnel; provided, however, that it shall not delegate the authority to refer any matter for the Authority's prior approval in accordance with the provisions of Clause 18.2.
 - (v) The Authority's Engineer shall aid and advise the Authority on any proposal for Change of Scope under Article 13.
 - (vi) In the event of any disagreement between the Parties regarding the meaning, scope and nature of Good Industry Practice, as set forth in any provision of the Agreement, the Authority's Engineer shall specify such meaning, scope and nature by issuing a reasoned written statement relying on good industry practice and authentic literature.

4. Construction Period

- (i) During the Construction Period, the Authority's Engineer shall review and approve the Drawings furnished by the Contractor along with supporting data, including the geo-technical and hydrological investigations, characteristics of materials from borrow areas and quarry sites, topographical surveys, and the recommendations of the Safety Consultant in accordance with the provisions of Clause 10.1 (vi). The Authority's Engineer shall complete such review and approval and send its observations to the Authority and the Contractor within 15 (fifteen) days of receipt of such Drawings; provided, however that in case of a Major Bridge or Structure, the aforesaid period of 15 (fifteen) days may be extended upto 30 (thirty) days. In particular, such comments shall specify the conformity or otherwise of such Drawings with the Scope of the Project and Specifications and Standards.
- (ii) The Authority's Engineer shall review and approve any revised Drawings sent to it by the Contractor and furnish its comments within 10 (ten) days of receiving such Drawings.
- (iii) The Authority's Engineer shall review and approve the Quality Assurance Plan submitted by the Contractor and shall convey its comments to the Contractor within a period of 21 (twenty one) days stating the modifications, if any, required thereto.
- (iv) The Authority's Engineer shall complete the review and approve of the methodology proposed to be adopted by the Contractor for executing the Works, and convey its comments to the Contractor within a period of 10 (ten) days from the date of receipt of the proposed methodology from the Contractor.

- (v) The Authority's Engineer shall grant written approval to the Contractor, where necessary, for interruption and diversion of the flow of traffic in the existing lane(s) of the Project Highway for purposes of maintenance during the Construction Period in accordance with the provisions of Clause 10.4.
- (vi) The Authority's Engineer shall review the monthly progress report furnished by the Contractor and send its comments thereon to the Authority and the Contractor within 7 (seven) days of receipt of such report.
- (vii) The Authority's Engineer shall inspect the Construction Works and the Project Highway and shall submit a monthly Inspection Report bringing out the results of inspections and the remedial action taken by the Contractor in respect of Defects or deficiencies. In particular, the Authority's Engineer shall include in its Inspection Report, the compliance of the recommendations made by the Safety Consultant.
- (viii) The Authority's Engineer shall conduct the pre-construction review of manufacturer's test reports and standard samples of manufactured Materials, and such other Materials as the Authority's Engineer may require.
- (ix) For determining that the Works conform to Specifications and Standards, the Authority's Engineer shall require the Contractor to carry out, or cause to be carried out, tests at such time and frequency and in such manner as specified in the Agreement and in accordance with Good Industry Practice for quality assurance. For purposes of this Paragraph 4 (ix), the tests specified in the IRC Special Publication-11 (Handbook of Quality Control for Construction of Roads and Runways) and the Specifications for Road and Bridge Works issued by MORTH (the "Quality Control Manuals") or any modification/substitution thereof shall be deemed to be tests conforming to Good Industry Practice for quality assurance.
- (x) The Authority's Engineer shall test check at least 50 (fifty) percent of the quantity or number of tests prescribed for each category or type of test for quality control by the Contractor.
- (xi) The timing of tests referred to in Paragraph 4 (ix), and the criteria for acceptance/ rejection of their results shall be determined by the Authority's Engineer in accordance with the Quality Control Manuals. The tests shall be undertaken on a random sample basis and shall be in addition to, and independent of, the tests that may be carried out by the Contractor for its own quality assurance in accordance with Good Industry Practice.
- (xii) In the event that results of any tests conducted under Clause 11.10 establish any Defects or deficiencies in the Works, the Authority's Engineer shall require the Contractor to carry out remedial measures.
- (xiii) The Authority's Engineer may instruct the Contractor to execute any work which is urgently required for the safety of the Project Highway, whether because of an accident, unforeseeable event or otherwise; provided that in case of any work required on account of a Force Majeure Event, the provisions of Clause 21.6 shall apply.
- (xiv) In the event that the Contractor fails to achieve any of the Project Milestones, the Authority's

Engineer shall undertake a review of the progress of construction and identify potential delays, if any. If the Authority's Engineer shall determine that completion of the Project Highway is not feasible within the time specified in the Agreement, it shall require the Contractor to indicate within 15 (fifteen) days the steps proposed to be taken to expedite progress, and the period within which the Project Completion Date shall be achieved. Upon receipt of a report from the Contractor, the Authority's Engineer shall review the same and send its comments to the Authority and the Contractor forthwith.

- (xv) The Authority's Engineer shall obtain from the Contractor a copy of all the Contractor's quality control records and documents before the Completion Certificate is issued pursuant to Clause 12.2.
- (xvi) Authority's Engineer may recommend to the Authority suspension of the whole or part of the Works if the work threatens the safety of the Users and pedestrians. After the Contractor has carried out remedial measure, the Authority's Engineer shall inspect such remedial measures forthwith and make a report to the Authority recommending whether or not the suspension hereunder may be revoked.
- (xvii) In the event that the Contractor carries out any remedial measures to secure the safety of suspended works and Users, and requires the Authority's Engineer to inspect such works, the Authority's Engineer shall inspect the suspended works within 3 (three) days of receiving such notice, and make a report to the Authority forthwith, recommending whether or not such suspension may be revoked by the Authority.
- (xviii) The Authority's Engineer shall carry out, or cause to be carried out, all the Tests specified in Schedule-K and issue a Completion Certificate, as the case may be. For carrying out its functions under this Paragraph 4 (xviii) and all matters incidental thereto, the Authority's Engineer shall act under and in accordance with the provisions of Article 12 and Schedule-K.

5. Maintenance Period

- (i) The Authority's Engineer shall aid and advise the Contractor in the preparation of its monthly Maintenance Programme and for this purpose carry out a joint monthly inspection with the Contractor.
- (ii) The Authority's Engineer shall undertake regular inspections, at least once every month, to evaluate compliance with the Maintenance Requirements and submit a Maintenance Inspection Report to the Authority and the Contractor.
- (iii) The Authority's Engineer shall specify the tests, if any, that the Contractor shall carry out, or cause to be carried out, for the purpose of determining that the Project Highway is in conformity with the Maintenance Requirements. It shall monitor and review the results of such tests and the remedial measures, if any, taken by the Contractor in this behalf.
- (iv) In respect of any defect or deficiency referred to in Paragraph 3 of Schedule- E, the Authority's Engineer shall, in conformity with Good Industry Practice, specify the permissible limit of

deviation or deterioration with reference to the Specifications and Standards and shall also specify the time limit for repair or rectification of any deviation or deterioration beyond the permissible limit.

- (v) The Authority's Engineer shall examine the request of the Contractor for closure of any lane(s) of the Project Highway for undertaking maintenance/repair thereof, and shall grant permission with such modifications, as it may deem necessary, within 5 (five) days of receiving a request from the Contractor. Upon expiry of the permitted period of closure, the Authority's Engineer shall monitor the reopening of such lane(s), and in case of delay, determine the Damages payable by the Contractor to the Authority under Clause 14.5.

6. Determination of costs and time

- (i) The Authority's Engineer shall determine the costs, and/or their reasonableness, that are required to be determined by it under the Agreement.
- (ii) The Authority's Engineer shall determine the period of Time Extension that is required to be determined by it under the Agreement.
- (iii) The Authority's Engineer shall consult each Party in every case of determination in accordance with the provisions of Clause 18.5.

7. Payments

- (i) The Authority's Engineer shall withhold payments for the affected works for which the Contractor fails to revise and resubmit the Drawings to the Authority's Engineer in accordance with the provisions of Clause 10.2 (iv) (d).
- (ii) Authority's Engineer shall -
 - (a) within 10 (ten) days of receipt of the Stage Payment Statement from the Contractor pursuant to Clause 19.4, determine the amount due to the Contractor and recommend the release of 90 (ninety) percent of the amount so determined as part payment, pending issue of the Interim Payment Certificate; and
 - (b) within 15 (fifteen) days of the receipt of the Stage Payment Statement referred to in Clause 19.4, deliver to the Authority and the Contractor an Interim Payment Certificate certifying the amount due and payable to the Contractor, after adjustments in accordance with the provisions of Clause 19.10.
- (iii) The Authority's Engineer shall, within 15 (fifteen) days of receipt of the Monthly Maintenance Statement from the Contractor pursuant to Clause 19.6, verify the Contractor's monthly statement and certify the amount to be paid to the Contractor in accordance with the provisions of the Agreement.
- (iv) The Authority's Engineer shall certify final payment within 30 (thirty) days of the receipt of the

Construction and upgradation of existing road to 2-lane with Paved shoulder from km. 20.340 (Rongli Bazzar) to km. 26.588 (Rongli Bypass End) and upgradation of existing road at km 20.600 & km 26.400 for length of 0.520 km & 0.554 km of Rhenok – Menla spur (NH-717B) Package-II A on EPC Basis under SARDP-NE Phase 'A' in the State of Sikkim.

final payment statement of Maintenance in accordance with the provisions of Clause 19.16.

8. Other duties and functions

The Authority's Engineer shall perform all other duties and functions as specified in the Agreement.

9. Miscellaneous

- (i) A copy of all communications, comments, instructions, Drawings or Documents sent by the Authority's Engineer to the Contractor pursuant to this TOR, and a copy of all the test results with comments of the Authority's Engineer thereon, shall be furnished by the Authority's Engineer to the Authority forthwith.
- (ii) The Authority's Engineer shall retain at least one copy each of all Drawings and Documents received by it, including 'as-built' Drawings, and keep them in its safe custody.
- (iii) Within 90 (ninety) days of the Project Completion Date, the Authority's Engineer shall obtain a complete set of as-built Drawings, in 2 (two) hard copies and in micro film form or in such other medium as may be acceptable to the Authority, reflecting the Project Highway as actually designed, engineered and constructed, including an as-built survey illustrating the layout of the Project Highway and setback lines, if any, of the buildings and structures forming part of Project Facilities; and shall hand them over to the Authority against receipt thereof.
- (iv) The Authority's Engineer, if called upon by the Authority or the Contractor or both, shall mediate and assist the Parties in arriving at an amicable settlement of any Dispute between the Parties.
- (v) The Authority's Engineer shall inform the Authority and the Contractor of any event of Contractor's Default within one week of its occurrence.

Schedule - O

(See Clauses 19.4 (i), 19.6 (i), and 19.8 (i))

Forms of Payment Statements

1. Stage Payment Statement for Works

The Stage Payment Statement for Works shall state:

- (a) the estimated amount for the Works executed in accordance with Clause 19.3 (i) subsequent to the last claim;
- (b) amounts reflecting adjustments in price for the aforesaid claim;
- (c) the estimated amount of each Change of Scope Order executed subsequent to the last claim;
- (d) amounts reflecting adjustment in price, if any, for (c) above in accordance with the provisions of Clause 13.2 (iii) (a);
- (e) total of (a), (b), (c) and (d) above;
- (f) Deductions:
 - i. Any amount to be deducted in accordance with the provisions of the Agreement except taxes;
 - ii. Any amount towards deduction of taxes; and
 - iii. Total of (i) and (ii) above.
- (g) Net claim: (e) - (f) (iii);
- (h) The amounts received by the Contractor upto the last claim:
 - iv. For the Works executed (excluding Change of Scope orders);
 - v. For Change of Scope Orders, and
 - vi. Taxes deducted

2. Monthly Maintenance Payment Statement

The monthly Statement for Maintenance Payment shall state:

- (a) the monthly payment admissible in accordance with the provisions of the Agreement;
- (b) the deductions for maintenance work not done;
- (c) net payment for maintenance due, (a) minus (b);
- (d) amounts reflecting adjustments in price under Clause 19.12; and
- (e) amount towards deduction of taxes

3. Contractor's claim for Damages

Note: The Contractor shall submit its claims in a form acceptable to the Authority.

Schedule - P

(See Clause 20.1)

Insurance

1. Insurance during Construction Period

- (i) The Contractor shall effect and maintain at its own cost, from the Appointed Date till the date of issue of the Completion Certificate, the following insurances for any loss or damage occurring on account of Non Political Event of Force Majeure, malicious act, accidental damage, explosion, fire and terrorism:
 - (a) insurance of Works, Plant and Materials and an additional sum of [15 (fifteen)] per cent of such replacement cost to cover any additional costs of and incidental to the rectification of loss or damage including professional fees and the cost of demolishing and removing any part of the Works and of removing debris of whatsoever nature; and
 - (b) insurance for the Contractor's equipment and Documents brought onto the Site by the Contractor, for a sum sufficient to provide for their replacement at the Site.
- (ii) The insurance under sub para (a) and (b) of paragraph 1(i) above shall cover the Authority and the Contractor against all loss or damage from any cause arising under paragraph 1.1 other than risks which are not insurable at commercial terms.

2. Insurance for Contractor's Defects Liability

The Contractor shall effect and maintain insurance cover of not less than 15% of the Contract Price for the Works from the date of issue of the Completion Certificate until the end of the Defects Liability Period for any loss or damage for which the Contractor is liable and which arises from a cause occurring prior to the issue of the Completion Certificate. The Contractor shall also maintain other insurances for maximum sums as may be required under the Applicable Laws and in accordance with Good Industry Practice.

3. Insurance against injury to persons and damage to property

- (i) The Contractor shall insure against its liability for any loss, damage, death or bodily injury, or damage to any property (except things insured under Paragraphs 1 and 2 of this Schedule or to any person (except persons insured under Clause 20.9), which may arise out of the Contractor's performance of this Agreement. This insurance shall be for a limit per occurrence of not less than the amount stated below with no limit on the number of occurrences.

The insurance cover shall be not less than: Rs. [*****]

- (ii) The insurance shall be extended to cover liability for all loss and damage to the Authority's property arising out of the Contractor's performance of this Agreement excluding:
 - (a) the Authority's right to have the construction works executed on, over, under, in or through any land, and to occupy this land for the Works; and
 - (b) damage which is an unavoidable result of the Contractor's obligations to

Construction and upgradation of existing road to 2-lane with Paved shoulder from km. 20.340 (Rongli Bazzar) to km. 26.588 (Rongli Bypass End) and upgradation of existing road at km 20.600 & km 26.400 for length of 0.520 km & 0.554 km of Rhenok – Menla spur (NH-717B) Package-II A on EPC Basis under SARDP-NE Phase 'A' in the State of Sikkim.

execute the Works.

4. Insurance to be in joint names

The insurance under paragraphs 1 to 3 above shall be in the joint names of the Contractor and the Authority.

Schedule-Q

(See Clause 14.10)

Tests on Completion of Maintenance Period

1. Riding Quality test:

Riding quality test: Riding quality of each lane of the carriageway shall be checked with the help of a calibrated bump integrator and the maximum permissible roughness for purposes of this Test shall be [2,200 (two thousand and two hundred only)] mm for each kilometre.

2. Visual and physical test:

The Authority's Engineer shall conduct a visual and physical check of construction to determine that all works and equipment forming part thereof conform to the provisions of this Agreement. The physical tests shall include measurement of cracking, rutting, stripping and potholes and shall be as per the requirement of maintenance mentioned in Schedule-E.

Schedule-R

(See Clause 14.10)

Taking Over Certificate

I,..... (Name and designation of the Authority's Representative) under and in accordance with the Agreement dated..... (the "Agreement"), for construction and upgradation of existing road to 2-lane with Paved shoulder from km. ` (Rongli Bazzar) to km. 26.588 (Rongli Bypass End) and upgradation of existing road at km 20.600 & km 26.400 for length of 0.520 km & 0.554 km of Rhenok – Menla spur (NH-717B) Package-IIA on Engineering, Procurement and Construction (the "EPC") basis

Through (Name of Contractor), hereby certify that the Tests on completion of Maintenance Period in accordance with Article 14 of the Agreement have been successfully undertaken to determine compliance of the Project Highway with the provisions of the Agreement and I hereby certify that the Authority has taken over the Project highway from the Contractor on this day

SIGNED, SEALED AND DELIVERED

(Signature)

(Name and designation of Authority's Representative)

(Address)

Construction and upgradation of existing road to 2-lane with Paved shoulder from km. 20.340 (Rongli Bazzar) to km. 26.588 (Rongli Bypass End) and upgradation of existing road at km 20.600 & km 26.400 for length of 0.520 km & 0.554 km of Rhenok – Menla spur (NH-717B) Package-II A on EPC Basis under SARDP-NE Phase 'A' in the State of Sikkim.

*******END OF THE DOCUMENT*******